

GUIDE TO CONCRETE CONSTRUCTION

T41



**CEMENT CONCRETE
& AGGREGATES AUSTRALIA**

PREFACE

Concrete remains a fundamental basis for the Australian construction industry. It provides a number of benefits – social, economic and environmental – that means it is a sustainable material.

This edition of Guide to Concrete Construction represents a major review of the volume. The contents were last reviewed in 2002 and much has changed in the composition and specification of concrete. The reader will notice changes in the structure and content of this volume to address these changes and ensure a contemporary description of concrete – its composition and performance.

The presentation of this edition has also changed to reflect modern communication where on-line resources are rapidly outstripping ‘hard-cover’ texts. In doing so, the revision of the content can be more readily achieved, allowing maintenance of the knowledge to reflect future changes that may be seen in codes and Standards – both Australian and international.

An important inclusion is a model for a general specification for concrete construction. This is to address a paucity of information regarding what is available in modern Australian concretes and to provide the basis for a conversation between supplier and clients which will continue to evolve the opportunities offered by concrete as a sustainable material.

This revision has been undertaken with the co-operation of a small but knowledgeable group of concrete technologists – all experts in their field. They have willingly contributed their skills and expertise in various aspects of concrete science to ensure the information presented is of relevance to those in the concrete supply chain. Cement Concrete and Aggregates Australia would like to thank all those listed in the Acknowledgements for this fine effort.

As ever, this volume provides a valuable source of information for those involved in the specification of concrete in Australia. It also gives a broad breadth of knowledge for those new to the subject of concrete – hopefully encouraging further study and research into a fundamental and essential building material.

Dr. Warren South
Director – Research and Technical Services
Cement Concrete and Aggregates Australia

August 2020

ACKNOWLEDGEMENTS

An undertaking such as this cannot be achieved without the input and co-operation of a group of dedicated individuals.

Cement Concrete and Aggregates Australia would like to recognise and thank the following people for their work and knowledge to the Guide to Concrete Construction.

Chief Reviewers

Mr Des Chalmers
Mr Tony Thomas

Contributors

Dr Daksh Baweja
Mr Greg van Rooyen
Ms Claire Neilsen
Mr Scott Munter
Mr Eric Lume
Mr John Nichols
Ms Robyn Gibson

Project Coordinators

Dr Duy Nguyen (written content)
Ms Nicole Kelly (graphic design)

Project Manager

Dr Warren South

CONTENTS

INTRODUCTION

PART I. PRINCIPLES OF PLAIN, REINFORCED, PRE-STRESSED AND FIBRE REINFORCED CONCRETE

PART II. CONSTITUENTS OF CONCRETE

- Section 1. Cements
- Section 2. Supplementary Cementitious Materials
- Section 3. Aggregates
- Section 4. Water
- Section 5. Admixtures
- Section 6. Reinforcing and Prestressing Steel Properties
- Section 7. Fibres for Concrete

PART III. CONCRETE MIX DESIGN

PART IV. SPECIFICATIONS, MANUFACTURE AND SUPPLY OF CONCRETE

- Section 8. Specifying & Ordering Concrete
- Section 9. Manufacture of Concrete
- Section 10. Supply of Concrete

PART V. CONCRETING SITE PRACTICES

- Section 11. Steel Reinforcement, Fibre and Prestressing Steel Handling and Fixing
- Section 12. Handling and Placing
- Section 13. Compaction
- Section 14. Finishing Concrete Flatwork
- Section 15. Curing
- Section 16. Control of Surface Finishes
- Section 17. Control of Cracking
- Section 18. Hot- and Cold-Weather Concreting

PART VI. SPECIAL CONCRETE APPLICATIONS

- Section 19. Slip-formed Concrete
- Section 20. Precast Concrete
- Section 21. Underwater–Tremie Concrete
- Section 22. Super-Workable Concrete

PART VII. DEVELOPMENTAL APPLICATIONS

- Section 23. Alternative Binders
- Section 24. Concrete Technology for the Future

PART VIII. PROPERTIES AND TESTING OF CONCRETE

- Section 25. Properties of Concrete
- Section 26. Concrete Testing and Quality Assurance

PART IX. RELATED SITE PRACTICES

- Section 27. Formwork
- Section 28. Occupational Health and Safety

PART X. ENVIRONMENTAL CONSIDERATIONS

PART XI. SPECIFICATION FOR CONCRETE CONSTRUCTION – BACKGROUND AND DEVELOPMENT

INDEX - GLOSSARY

GUIDE TO CONCRETE CONSTRUCTION

T41



CEMENT CONCRETE
& AGGREGATES AUSTRALIA

INTRODUCTION

In its most basic form, concrete is a mixture of cement ('Portland' or blended), water, and fine and coarse aggregates (sand and crushed rock or natural gravel). Concrete is plastic when first mixed, but it then sets and hardens into a strong, solid mass. In the plastic state it can be moulded or extruded into a variety of shapes. When hardened, it is strong and durable, able to support substantial loads and, at the same time, resist the effects of fire, weather, wear, and other deteriorating influences. Because of these properties concrete has become a construction material of great versatility and wide application.

The properties of concrete in both the plastic and the hardened states are dependent on the physical characteristics, the chemical composition and the proportions of the components used in the mixture. Plastic-state properties must be appropriate for the methods of handling, placing, compacting and finishing to be used in the job. Hardened-state properties must be appropriate for the purpose for which the concrete is to be used – i.e. it must be strong enough to carry the loads imposed on it and durable enough to resist the deteriorating influences of wear and weather.

If not properly placed and compacted (as discussed in Part V of this Guide), concrete will not achieve its potential strength and durability. It is important, therefore, that when delivered to the construction site, plastic concrete is sufficiently workable for it to be placed and compacted using the means available and in a timely manner.

Workability is achieved by having sufficient 'cement' paste (cementitious material and water) in the mixture to lubricate the particles of aggregate which allows them to move freely as the concrete is placed and compacted.

Generally, the greater the volume of cement paste in the mixture, the more workable will be the concrete. However, it is the volume of water in the paste which tends to be the dominant factor – the more fluid the paste, the more workable the concrete.

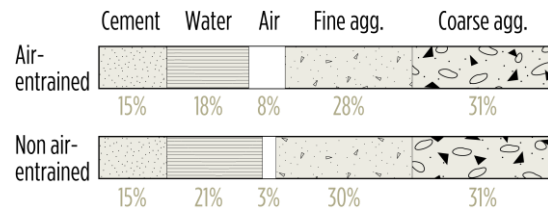

SMALL AGGREGATES IN RICH MIX (High Proportion of Cement Paste)

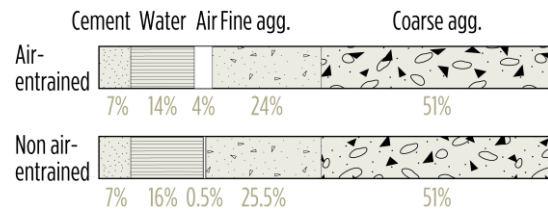

LARGE AGGREGATES IN LEAN MIX (Low Proportion of Cement Paste)

NOTE: From the above diagrams, which show mixes at the same slump, the following can be seen – (a) Coarse aggregate is generally the dominant material; (b) air-entrained mixes require less water to achieve a given slump; (c) even non air-entrained mixes contain some air. Mixes containing smaller aggregates typically require a higher 'cement' content to achieve a given strength than mixes with larger aggregates – as more paste is required to cover the higher surface area present with smaller aggregates

RANGES OF CONCRETE MIX PROPORTIONS

Achievement of many of the desirable hardened-state characteristics of concrete, particularly its strength and durability, depends to a great extent on the development of physical and chemical bonds both within the cement paste as it hydrates (i.e. reacts chemically with water) and between the cement paste and the aggregate particles as the concrete hardens.

For a given mix, maximum bond development will occur when the water content of the cement paste is at the minimum needed to achieve adequate workability and all air is expelled from the system. In this respect, cement paste is like any other glue – dilution weakens it.

When proportioning concrete mixes there are competing requirements that must be recognised. More water increases concrete workability (allowing it to be properly placed and finished) but as already noted, it also dilutes and weakens the cement paste. In concrete mix design (or proportioning – Part III of the Guide) it is necessary to strike a balance between the workability and strength/durability requirements of the project and/or specification.

In modern concrete technology, mix designers have at their disposal a range of materials other than the basic 'cement plus water plus aggregates' with which to modify the properties of concrete (Part II of this Guide). Modern concrete mixes almost invariably contain pozzolanic and other cementitious materials, one or more chemical admixtures, and where needed, special aggregates. Also, in structural design it is common practice to reinforce concrete in order to optimise concrete performance. Steel reinforcement and prestressing have been the preferred methods of providing this reinforcement. In more recent years other forms of reinforcement have also been developed to improve structural performance such as various types of fibres. The nature of these newer materials and their effects on the properties of concrete are discussed in subsequent Sections of this Guide.

The performance characteristics able to be achieved with modern concrete could have only been dreamed about by concrete technologists as little as 20-30 years ago. High performing cementitious materials and admixtures that allow highly workable mixes to be produced at very low water-to-cementitious materials ratios (W/C) have allowed concrete performance to soar to new heights – literally. High-rise structures of the dimensions now being built could not have been constructed with older concrete technologies. Concrete can also now (a) be 'put to sleep' for 2-3 days and then 'woken up' and used; (b) be successfully placed under-water (Part VI) and (c) be used to produce thin, high strength post-tensioned concrete floors in high-rise structures, saving materials, time and money. There seem to be few limits to how modern concrete can be used.

These advances do not mean that concrete as we know it does not face challenges. Concrete has been the 'victim of its own success' in some ways. With over 30 billion tonnes of concrete being placed throughout the world each year, supported by the manufacture of over 4 billion tonnes of cement, the sheer volume of materials and their manufacture present some environmental challenges. These have been discussed in Part X of this Guide. Developments of new alternative binders that

may one day replace 'Portland' cement are also discussed in Part VII, Section 23.

Despite the great advances in concrete technology and its ubiquitous use, concrete construction cannot be successfully carried out without consideration of many other factors. The diagram at the end of this 'Introduction' demonstrates the inter-dependence of concrete the material with a range of other factors that must be considered when building a concrete structure. Ultimately, the concrete structure must exist in a particular environment and these environmental conditions must be known. Architectural and engineering design must then be used to ensure that the concrete structure (a) is suited to the local environment, and (b) has design elements that allow it to function as its owners expect (Part I of the Guide). It is then up to the concrete technologist to create a concrete mix that suits these various needs and then for the project team to ensure that the concrete is properly placed, finished and cured to maximise its performance. It is the integration of all of these elements that creates the ultimately successful concrete structure.

The flexibility of concrete is such that (a) being able to be moulded when in the plastic state allows structures of many shapes and sizes to be built, and (b) its strength and durability allows these structures to be serviceable and durable for long periods of time. These benefits, along with its relatively low cost and 'local' manufacture, account for the world-wide success of concrete as a building material. However, the world does not stand still, and concrete technology continues to advance. Some recent technology improvements are described in Part VII, Section 24 of this Guide.

This edition of the Guide has been expanded to encapsulate many of the new advances in concrete technology and explains how concrete fits into the modern construction industry. The main purpose of this Guide is to provide practically based information about modern concrete technology and many of the construction techniques and processes used in concrete construction. It is worth noting that seldom is there a unique solution to achieving a satisfactory structure. Each case needs to be considered individually. The choice of materials will be influenced by local availability, while the

techniques employed to carry out the necessary associated processes (e.g. curing) will be influenced by the construction process and program being undertaken. In every case, consideration needs to be given to the ease with which a process can be carried out on-site. It is a truism that designing structures to be 'buildable' goes a long way to ensuring that the structure will achieve its design potential and perform appropriately throughout its design life. Therefore, designers and construction personnel need to understand the construction processes by which concrete structures are created, as well as having a good understanding of the material and how it should be used. This Guide is a resource to be used by those seeking further information about concrete, concrete technology and concrete construction.

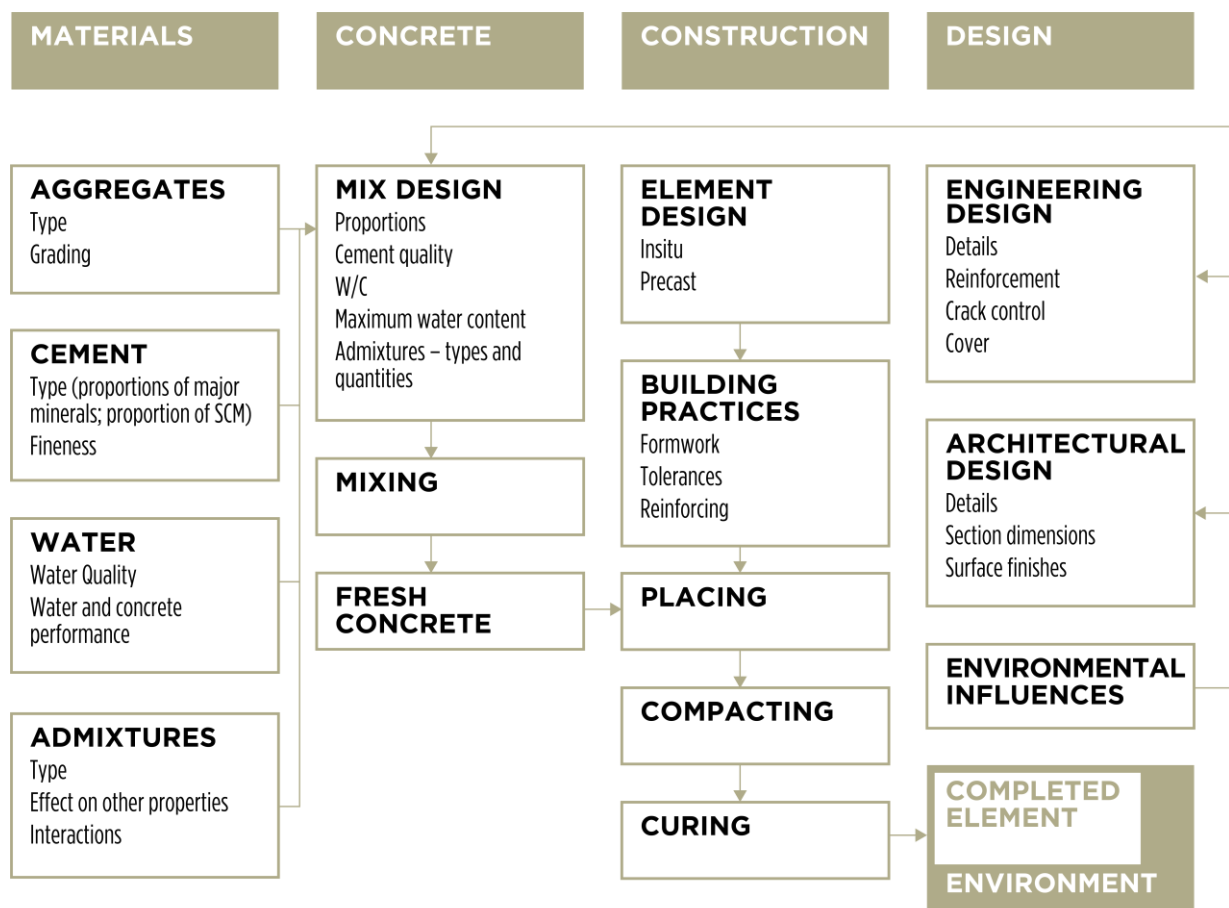

FACTORS INFLUENCING THE PERFORMANCE OF CONCRETE STRUCTURES

GUIDE TO CONCRETE CONSTRUCTION

T41



CEMENT CONCRETE
& AGGREGATES AUSTRALIA

CONTENTS

1. OUTLINE	2
2. BASIC PRINCIPLES OF PLAIN CONCRETE	4
2.1 GENERAL.....	4
2.2 TYPES OF STRESSES.....	5
2.3 PROPERTIES OF PLAIN CONCRETE	6
2.4 APPLICATIONS OF PLAIN CONCRETE.....	7
3. BASIC PRINCIPLES OF REINFORCED CONCRETE	7
3.1 GENERAL.....	7
3.2 TYPES OF STRESSES.....	7
3.3 STRESSES FOUND IN STRUCTURAL MEMBERS	9
3.4 BOND AND ANCHORAGE.....	10
4. BASIC PRINCIPLES OF PRESTRESSED CONCRETE	11
4.1 GENERAL.....	11
4.2 PRE-TENSIONING	12
4.3 POST-TENSIONING	12
4.4 APPLICATIONS.....	13
5. BASIC PRINCIPLES OF FIBRE REINFORCED CONCRETE	13
5.1 TYPES OF FIBRES.....	13
5.2 ACTION OF FIBRES IN CONCRETE	14
5.3 APPLICATIONS FOR FIBRES IN CONCRETE.....	15
6. REFERENCES.....	16

1. OUTLINE

Concrete structures generally incorporate reinforced and/or prestressed members. Many concrete structures do require some form of reinforcement, most commonly steel bars or wires and/or other forms of reinforcement such as steel or synthetic fibres, in order to carry their design loads. However, this is not always the case, and, in some circumstances, structures may contain elements that are formed from

plain concrete with no reinforcement required to perform their function. This part provides basic information on the principles and applications for plain (unreinforced) concrete, reinforced concrete, prestressed concrete and fibre reinforced concrete.

Plain concrete (containing no reinforcement) can be used in situations where the tensile strength of the concrete alone is sufficient. Plain concrete members are generally limited to sub-bases and slabs on ground with low loading or in rare cases to industrial slabs with carefully constructed sub-base and designed jointing.

Reinforced concrete is a material that combines concrete and reinforcement into a composite whole. Whilst steel bars, wires and mesh are by far the most widely used forms of reinforcement, other materials are used in special applications, e.g. carbon-filament reinforcement and steel/synthetic fibres. AS 3600 defines reinforcement as 'steel bar, wire, or mesh but not tendons', whereas it defines 'tendons' as a coverall for prestressing or post-tensioning tendons, bars or wires.

Prestressed concrete structures use a particular type of reinforcing system that increases the efficiency of the reinforcement. In prestressed concrete members, the concrete is placed in compression before the member is subjected to the applied loads. The compression force is provided by tensioned tendons (high tensile steel wires, strands or bars) before they are bonded to the concrete and then transfer this force to the concrete. Placing the concrete in compression increases its ability to withstand loads.

Reinforcement or prestressing of concrete combines the material properties of steel and concrete to provide a versatile construction material. Plain concrete (unreinforced) has a high compressive strength but a low tensile strength. Steel, on the other hand, has a very high tensile strength and compressive strength, but it is much more expensive to use steel for its compressive strength compared to concrete. By combining steel and concrete into a composite material, it is possible to make use of both the high tensile strength of steel and the compressive strength of concrete cost-effectively.

Aside from strength properties, concrete has other beneficial attributes such as plasticity, which enables it to be moulded readily into different shapes, and relatively high fire resistance, which can be used to protect steel reinforcement embedded in the concrete.

Some advantages to combining steel and concrete are summarised in **Table I.1**.

Table I.1 – Characteristics of Steel and Concrete

Characteristics of concrete	Characteristics of steel
High compressive strength	High compressive strength
Low tensile strength	High tensile strength
Relatively high fire resistance	Relatively low fire resistance
Plastic and mouldable when fresh	Difficult to mould and shape except at high temperatures
Relatively inexpensive	Relatively expensive

The aim of the reinforced concrete designer is to combine the reinforcement with the concrete in an efficient manner. The design requires sufficient of the (relatively expensive) reinforcement to be incorporated to resist the tensile and shear forces which may occur in the structure. The design will also utilise the (comparatively inexpensive) concrete to resist the compressive forces in the structure.

To achieve this aim, the designer needs to determine not only the amount of reinforcement to be used, but also how it is to be distributed and where it is to be positioned. These latter decisions are critical to the successful performance of reinforced concrete and it is imperative that, during construction, reinforcement be positioned exactly as specified by the designer. It is therefore important that both those who supervise the fixing of reinforcement on the jobsite and those who fix it, have a basic appreciation of the

principles of reinforced concrete as well as the practices of fixing reinforcement.

Like reinforced concrete, prestressed concrete is a composite material in which the weakness of concrete in tension is compensated by the tensile strength of steel – in this case, steel wires, strands, or bars.

The compressive strength of the concrete is used to advantage in prestressed concrete by applying an external compressive force to the concrete, which either keeps it permanently in compression during its service life loading (fully-prestressed) or limits the value of any tensile stress which arises under load (partial prestressing).

The pre-compressing or prestressing of concrete can be likened to picking up a row of books by pressing the books together **Figure I.1**. If a larger number of books is used (a longer span), the greater the force that has to be applied at either end of the row to prevent the row (the beam) collapsing under its own weight. A load applied to the top of the books would require an even greater force to be applied to prevent collapse.

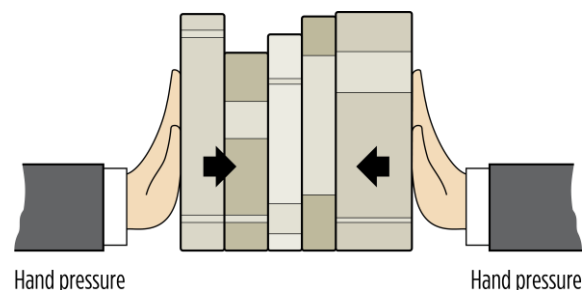

Figure I.1 – Prestressing can be Likened to Picking up a Row of Books

In reinforced concrete, the steel reinforcement carries all of the tensile stresses and in some cases, some of the compressive stresses. In prestressed concrete, the tendons are used primarily to keep the concrete in compression. The tendons are stretched (placing them in tension) and then bonded to the hardened concrete before releasing them. The force in the tendons is transferred to the concrete and so compressing it.

A fully prestressed concrete member is designed to be permanently under

compression, effectively eliminating most tensile cracking. In this case, if the member is slightly overloaded, some tension cracks may form but these should close up and disappear once the overload is removed, provided always that the steel has not been strained beyond its elastic limit. In partially prestressed members, some tensile stresses and therefore some cracking, is accepted at the design ultimate load.

In reinforced concrete, the steel is not designed to operate at a high level of stress, as elongation of the steel will lead to cracking of the concrete. In prestressed concrete, the steel does carry very high levels of tensile stress. Whilst it is well able to do this, there are some penalties attached. Firstly, because of the forces involved, considerable care must be exercised in stretching the tendons and securing them. Stressing operations should always be carried out or at least supervised by skilled personnel. Secondly, the structure must be able to compress, otherwise the full, beneficial prestressing forces cannot act on the concrete. The designer must detail the structure so that the necessary movements can occur during stressing operations.

Reinforcement of concrete using steel or synthetic fibres is carried out for a range of beneficial reasons. The quantity and type of fibre used is selected for the benefit that is to be achieved. Fibres are commonly used in conjunction with steel reinforcement but may be used with plain concrete as the only form of reinforcement in some cases. The types of fibres, their benefits and common applications are briefed in the following sub-sections, with more details provided in Part II, Section 7. Also, fibre distribution and testing methods are given in Part V, Section 11.

Information on types and properties of reinforcing and prestressing steel is given in Part II, Section 6. Part V, Section 11 outlines the guidance on handling and fixing of reinforcing steel as well as the techniques used to tension the tendons and to bond it to the concrete. Also, safety precautions which should be observed during reinforcement detailing and stressing operations are provided in Part V, Section 11 and Part IX, Section 28.

2. BASIC PRINCIPLES OF PLAIN CONCRETE

2.1 GENERAL

Plain concrete is designed to be used in a structure without any form of reinforcement other than that required for transfer of loads across joints. Plain concrete is commonly used in 'on-ground' applications such as pavements, including bases, sub-bases or 'blinding layers' as well as wearing surfaces (**Figure I.2**).

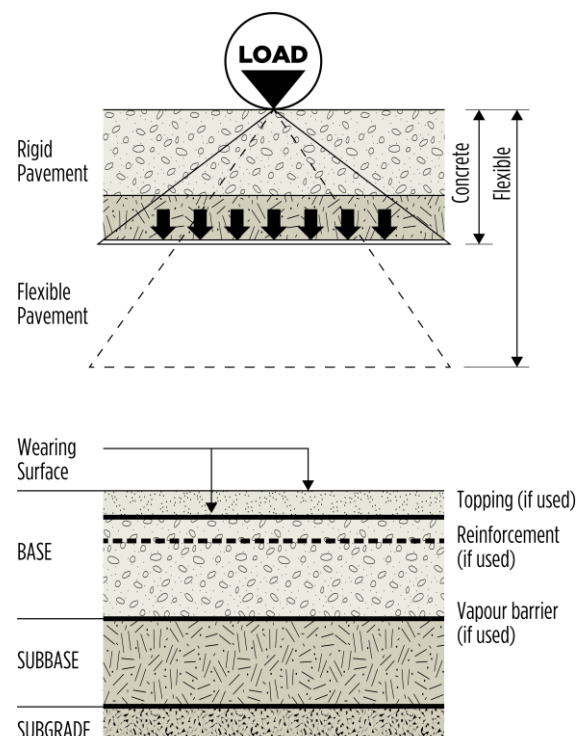

Elements of a typical concrete industrial pavement

Figure I.2 – Pavement Construction and Load Transfer

The design of a pavement must include appropriate design of jointing detail and design of the thickness of the concrete base. This should be designed to maintain its integrity while transferring loads on the pavement to the sub-base and subgrade below it (**Figure I.2**).

Concrete used in plain concrete pavement is commonly specified by performance properties including compressive strength grade, flexural tensile strength and maximum drying shrinkage. Other prescriptive properties may be included in the concrete mix design such as

maximum size of aggregate and total coarse/fine aggregate grading limits, where the design of the transfer of loads across joints is totally reliant on aggregate interlock.

2.2 TYPES OF STRESSES

The types of stresses that occur in plain concrete are dependent on the structure being designed. In pavements, the key stresses relate to loading. A load on the surface of a plain concrete rigid pavement induces compressive stresses in the top surface as well as tensile stresses in the lower surface if the concrete is placed on a flexible sub-base and sub-grade (see **Figure I.3**). The magnitude of these stresses is dependent, in part, on the thickness of the plain concrete pavement and also on the properties of the sub-base and sub-grade.

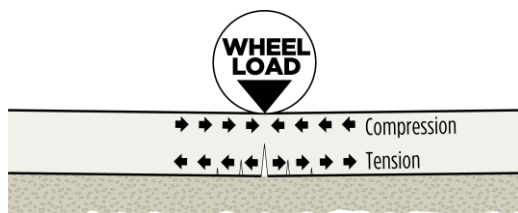

Figure I.3 – Pavement Loading

Much of the strength of a plain concrete pavement is dependent on the properties of sub-base and subgrade supporting the pavement. The principle property of the subgrade and sub-base are their combined elastic modulus (often represented as ‘modulus of sub-grade reaction’ and used in pavement design). The elastic modulus of subgrade materials is directly related to the modulus of subgrade reaction and is also related to a commonly measured and specified value of the sub-grade known as the California Bearing Ratio (or CBR). A representation of this relationship is indicated in **Figure I.4** [derived from Putri et al].

The other key location where stresses in plain concrete pavements must be considered are at the joints in the pavement base. If the joint is working correctly, it limits differential movement in the vertical direction between jointed slab segments while allowing some limited movement in the horizontal direction. To do this

the impact of a vertical load on a slab needs to be restrained by shear force transfer across the joint in the vertical direction (see **Figure I.5**).

APPROX. RELATIONSHIP BETWEEN SUB-BASE CBR AND MOE

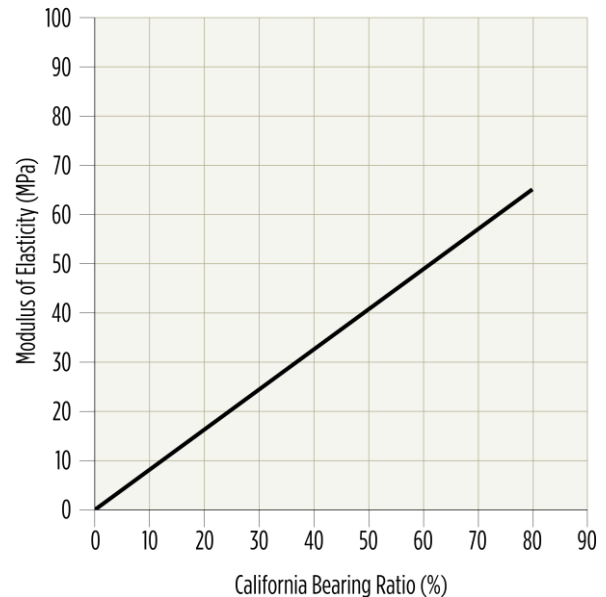
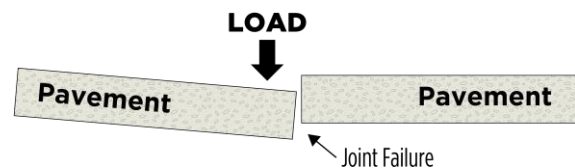
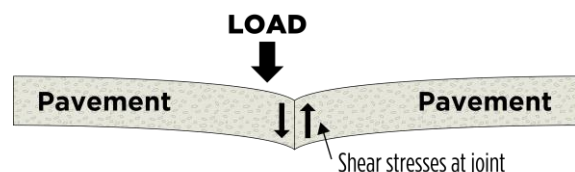

Figure I.4 – The Approximate Relationship between Granular Sub-Grade and Sub-Base CBR with Elastic Modulus



Poor Joint design leading to inability to transfer load across the joint



Good Joint design allowing full load transfer across the joint

Figure I.5 – Shear Stresses are Controlled at the Joint to Prevent Failure

Figure I.5 shows the idealised load transfer between jointed segments of an unreinforced pavement. Joints should allow for concrete dimensional change caused by shrinkage and thermal expansion/contraction without allowing differential vertical movement between two pavement segments under applied loads. There are various methods used to allow joints

to perform the function and some of the common joint designs include:

- Saw cut and tooled contraction joints;
- Dowel joints;
- Key joints.

These three common joint methods are described in **Figure I.6**. Other less common methods are not discussed here, but are detailed in Part V, Section 17 of this Guide.

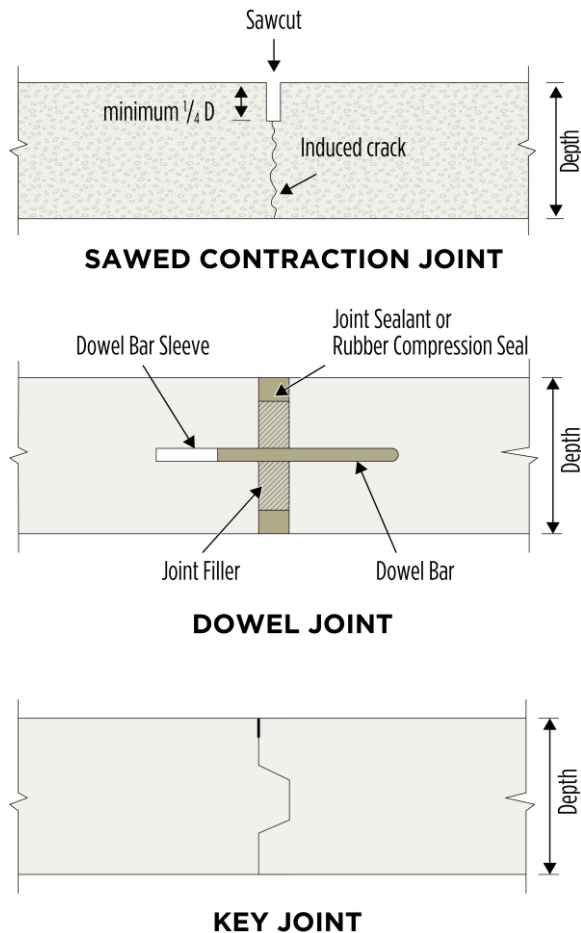

Figure I.6 – Common Pavement Joint Details

Saw Cut Joints – The purpose of saw cut joints is to restrain differential vertical and horizontal movements in the same direction as the joint but allow limited horizontal movement perpendicular to the plane of the joint. Saw cut joints rely on aggregate interlock in the cracked section below the saw cut (cut to a minimum of one quarter of the slab depth) to transfer load across the joint. The effectiveness of this form of joint is dependent on the joint opening, maximum aggregate size and distribution of coarse aggregate in the concrete mix. If the joint

opening is too great, the load transfer may become ineffective leading to failure of the joint. This type of joint is common in lightly loaded pavements such as footpaths. With careful design and construction, sawn joints can be used in road and aircraft pavements.

Dowel Joints – The purpose of dowel joints is to restrain differential vertical and horizontal movements in the same direction as the joint but allow horizontal movement perpendicular to the plane of the joint. Dowel joints are often used for interior industrial pavements and commonly in conjunction with key joints. In this case dowel joints may be used in the longer direction of a jointed segment and key joints in the narrower direction. It is critical that dowels are placed accurately and perpendicular to the joint direction.

Key Joints – The purpose of key joints is to restrain differential vertical movements in the same direction as the joint but allow horizontal movement perpendicular to the plane of the joint as well as allowing horizontal movement in the plane of the joint. Key joint effectiveness diminishes as the joint opens. Care is required in design using key joints where a greater joint opening is expected (higher shrinkage or thermal movement).

2.3 PROPERTIES OF PLAIN CONCRETE

The key properties of un-reinforced (plain) concrete are noted in **Table I.1**. These are relatively high compressive strength, low tensile strength and relatively high fire resistance. It should be noted that concrete has low shear strength in comparison to steel but has a moderately high abrasion resistance depending on its compressive strength grade. This supports a view that plain concrete is best suited for purposes where it is not required to rely heavily on its tensile or shear strength and uses such as concrete pavements are a good fit for these properties provided that the sub-grade and sub-base are sufficiently high modulus of elasticity to provide support to the concrete pavement. In addition to this, the pavement joint spacing needs to be sufficiently low (a maximum of 25 to 30 times the pavement

thickness is recommended) to aid control of early cracking between joints and the concrete strength and pavement depth sufficiently high to ensure that tensile stress levels are under the specified maximum tensile strength of the concrete.

2.4 APPLICATIONS OF PLAIN CONCRETE

The quantity of concrete used in plain concrete structures is quite high but is still economical in certain applications. Some common applications are listed below:

- Concrete road pavements;
- Aircraft pavements;
- Industrial pavements (interior);
- 'Blinding Layers' over subgrade as a working platform for further concrete pavement construction;
- Sub-base for unreinforced concrete highway construction;
- High or low strength fill where washout resistance greater than that of granular road-base is required;
- Gravity dam construction and roller compacted concrete construction more generally.

3. BASIC PRINCIPLES OF REINFORCED CONCRETE

3.1 GENERAL

Whilst the behaviour of reinforced concrete is actually quite complex, for practical purposes we can assume that steel and concrete can combine to act compositely for the following reasons:

- Upon hardening, concrete bonds firmly to steel reinforcement so that, when loads are applied, the two act as though they are one. The tensile forces are carried by the reinforcement and the tensile contribution from the concrete is ignored;
- When subjected to changes in temperature, concrete and steel expand or contract by similar amounts. They therefore remain firmly bonded and

continue to act compositely;

- Concrete, having a relatively high resistance to fire, and a relatively low thermal conductivity, protects the embedded steel reinforcement with low fire resistance, thereby substantially increasing the time taken for the temperature of the reinforcement to rise to a level where there is a substantial loss of strength;
- Concrete provides an alkaline environment for steel embedded in it. This protects the steel from corrosion and, because concrete is relatively inert to chemicals other than acids, it continues to do so for long periods of time in all but very hostile environments.

The key aims of a designer of reinforced concrete are:

- To be able to determine the amount and the location of reinforcement so that it resists the stresses which develop in the concrete under load;
- To ensure that the steel has a sufficient layer of an appropriate quality of concrete covering it to protect it from the environment to which it might otherwise be exposed;
- To ensure that the steel has a sufficient layer of the appropriate quality of concrete around it to protect it against fire.

3.2 TYPES OF STRESSES

The principal types of stresses that develop in structural elements or members, illustrated in **Figure I.7**, are:

- Compressive stresses – those which tend to cause the member to compact and crush;
- Tensile stresses – those which tend to cause the member to stretch and crack; and
- Shear stresses – those which tend to cause adjacent portions of the member

to slide across each other.

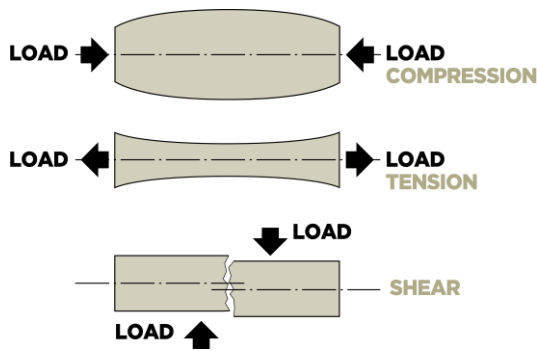

Figure 1.7 – Types of Stresses

It is very rare that there is only one of these types of stresses found in a structural member. Generally, some combination of compressive, tensile and shear stresses will be encountered, and it is the job of the designer to determine these and locate the appropriate amount of reinforcement necessary to resist this combination of stresses.

Whilst shear stresses can be quite complex in the way in which they act and react, two principal types can be distinguished – vertical and horizontal.

Vertical shear stresses occur, for example, near the end supports of beams but are less near the centre of the beam where the vertical shear forces are more in balance **Figure 1.8**.

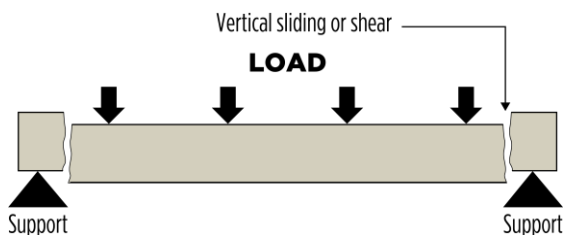

Figure 1.8 – Vertical Shear Stresses

Horizontal shear stresses occur as the beam bends and the (imaginary) horizontal layers within it will try to slide over one another **Figure 1.9**.

When vertical and horizontal shear stresses react with one another, they produce what is known as diagonal tension which, in turn, tends to produce diagonal cracking. This is illustrated

in **Figure 1.10** and commonly occurs near the ends of heavily loaded beams.

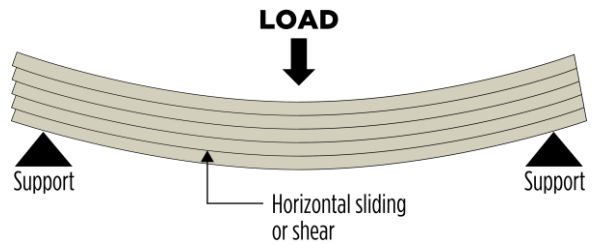

Figure 1.9 Horizontal Shear Stresses

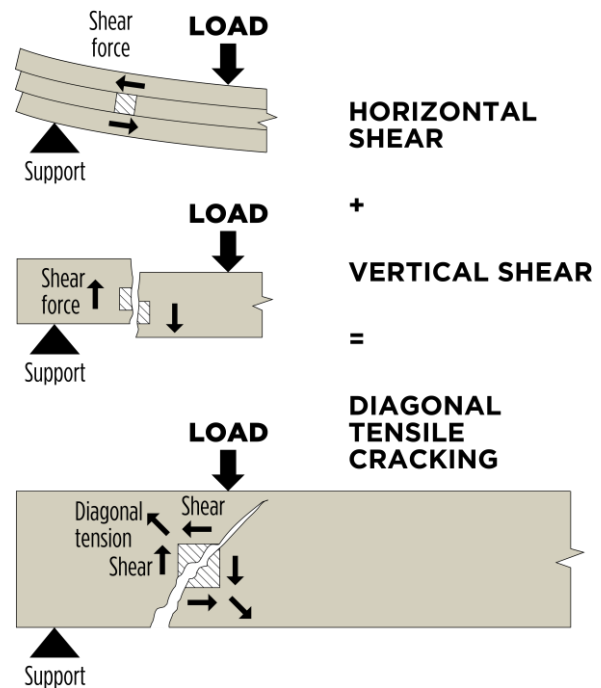

Figure 1.10 – Diagonal Tension Cracks

To resist such cracking, reinforcement must be provided. This is done commonly by providing stirrups or, on occasions, cranking the horizontal reinforcement **Figure 1.11**. The spacing between stirrups is closer near the supports and increases as the distance from the end of the beam increases.

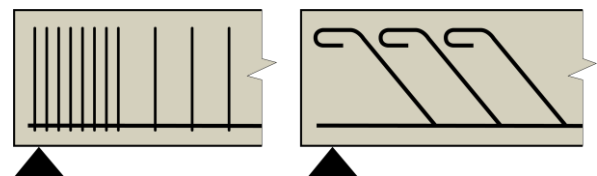

Figure 1.11 – Reinforcement to Resist Diagonal Tension

3.3 STRESSES FOUND IN STRUCTURAL MEMBERS

Simply-Supported Beams and Slabs – A simply-supported reinforced concrete beam under load is shown in **Figure 1.12**. When such a beam is loaded, either by a central point load or a uniformly distributed load along its length, it tends to sag or deflect downwards. This causes the top of the beam to compress and the bottom of the beam to stretch and go into tension. Reinforcement is placed in the bottom of the beam to resist the tensile stresses. Compressive reinforcement will not normally be required in the top of the beam due to high compressive strength of the concrete. The tensile stresses in the bottom of the beam induce tension in the reinforcement and cracking in the concrete. Overloads will cause the reinforcement to elongate further and further cracking to occur, until, under severe overload, the beam will fail.

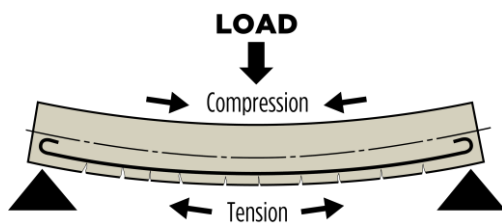

Figure 1.12 – Simply Supported Beams or Slabs

Simple Cantilevers – When a simple cantilever beam or slab is loaded, it tends to droop or deflect as shown in **Figure 1.13**. Tensile stresses occur in the top of the beam or slab and compressive stresses in the bottom. In this case, therefore, the reinforcement is placed in the top of the beam.

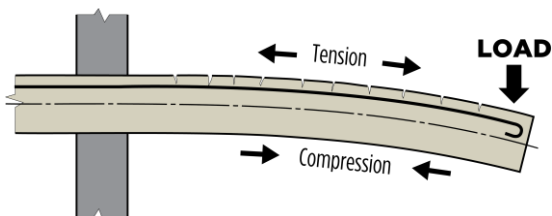

Figure 1.13 – Simple Cantilever Beams or Slabs

Fixed-Ended Beams – When a beam which is fixed at both ends is loaded it tends to bend as illustrated in **Figure 1.14**. Tension will again

occur in the bottom of the beam and in this case also in the top of the beam close to the supports. Reinforcement must be placed in the top near the supports and in the bottom across the centre.

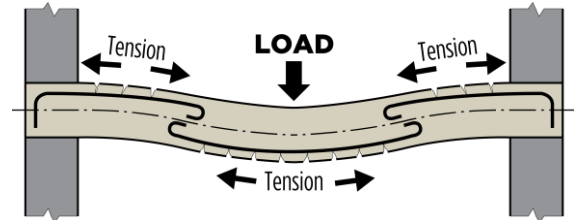

Figure 1.14 – Fixed-Ended Beams or Slabs

Multi-Span Beams and Slabs – As may be seen in **Figure 1.15**, beams which span between more than two supports tend to flex or bend over the intermediate supports, necessitating reinforcement in the top of the beam at these points. They sag or deflect between supports, necessitating bottom reinforcement in the beam at these points.

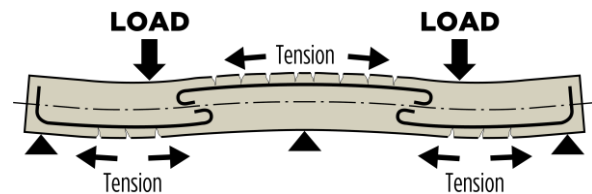

Figure 1.15 – Multi-Span Beams or Slabs

Retaining Walls – Retaining walls may be likened to a vertical beam which is fixed at one end. The earth, or other material being retained, then causes the wall to act as a cantilever. However, in this case, the footing of the wall is also involved and it tends to bend or distort as load is applied. The resultant stresses are illustrated in **Figure 1.16** which also shows how the reinforcement would be distributed to resist these stresses.

Columns – Whilst columns are designed primarily to support axial loads, bending moments are invariably introduced by uneven or eccentric distribution of the loads. Columns also tend to buckle, this tendency being a function of their slenderness. Tall, thin columns are more prone to this than are short, stocky columns.

All columns will require some reinforcement to resist these tendencies. Since, in practice, the load distribution on a column may change during its service life, it is normal to provide this reinforcement on all faces of a column to ensure that it remains safe (i.e. able to carry its loads), no matter how the distribution of the loads may change. This reinforcement also contributes to the ability of the column to carry axial compression loads.

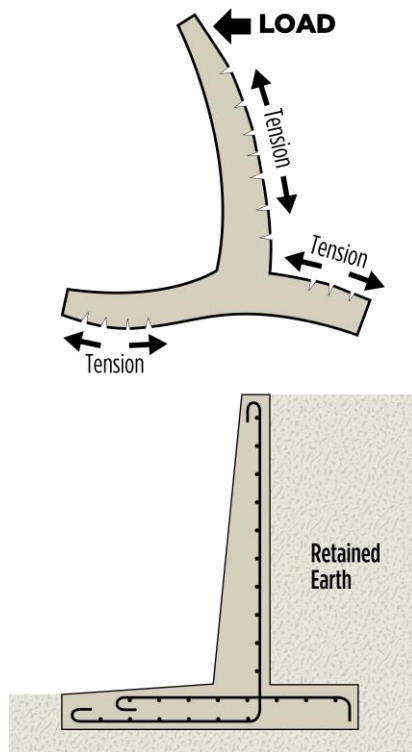

Figure I.16 – Retaining Walls

This is illustrated in **Figure I.17** which shows a column supporting a series of beams. As may be readily imagined, the loads on this column could change quite significantly as the loads on the beams change. Hence the column could tend to bend in any direction.

To resist the tensile stresses caused by bending in a column, vertical reinforcement is placed in the outer faces. This is illustrated in **Figure I.18**. In addition, stirrups or ties are used to:

- Help prevent lateral bursting of the column under axial loads;
- Restrain the longitudinal reinforcement from buckling; and

- Hold the main reinforcement firmly in place during concreting.

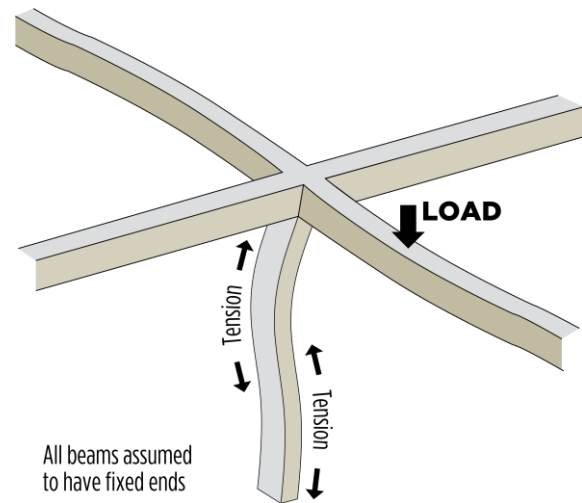

Figure I.17 – Stresses in Columns

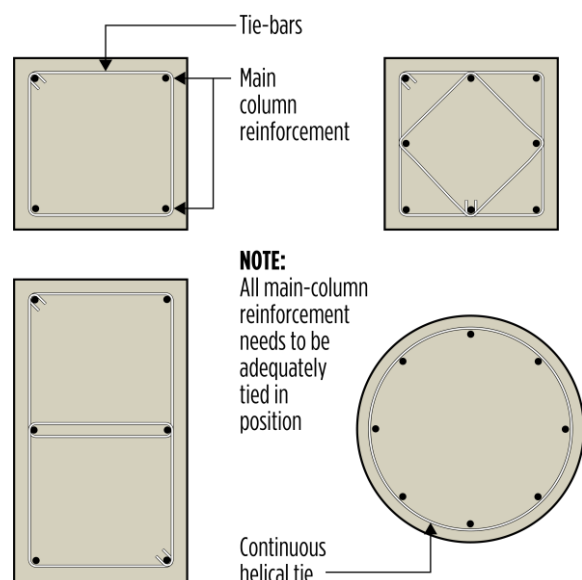

Figure I.18 – Typical Arrangement of Column Reinforcement

3.4 BOND AND ANCHORAGE

As has been noted already, steel and concrete act compositely when they are firmly bonded together. The strength of this bond is an important consideration in the design of reinforced concrete. It is dependent on the concrete being thoroughly compacted around the reinforcement and on the latter being clean and free of loose scale, rust or other material. Formwork oil, for example, will destroy the bond between steel and concrete. The bond may be increased by the use of higher strength

concrete or by the use of deformed reinforcing bars. These ribs or deformations rolled onto the bar surface results in the bond with concrete being increased. AS 3600 requires that all reinforcement except that for fitments be deformed bars, see **Figure I.19**.



Figure I.19 – Typical 500-MPa Deformed Bar

To ensure that adequate anchorage is achieved in the reinforcement, it is normally extended beyond the region of tensile stress for a sufficient length so that the bond between the reinforcement and the concrete can develop the tensile stress required at that point in the bar. Where this is not possible for some reason, or as an additional safety factor, bends or hooks in reinforcement are often used to provide the anchorage required.

4. BASIC PRINCIPLES OF PRESTRESSED CONCRETE

4.1 GENERAL

The action of a simply-supported reinforced concrete beam under load is described in subsection 3.3 and shown in **Figure I.12**. In a simply-supported prestressed concrete beam, the application of the prestress normally results in a small upward camber or deflection of the beam as the concrete, on its underside, compresses under the action of the prestress (**Figure I.20(a)**). When an external load is then applied, the beam deflects or moves downwards, negating (or neutralising) the upward camber (**Figure I.20(b)**). If an overload is applied, the beam will deflect still further and commence to behave in the same way as a

reinforced beam. Tensile stresses will occur in the concrete and cracking will result (**Figure I.20(c)**). Severe overloads will cause the beam to fail as the steel is stretched beyond its ultimate limit.

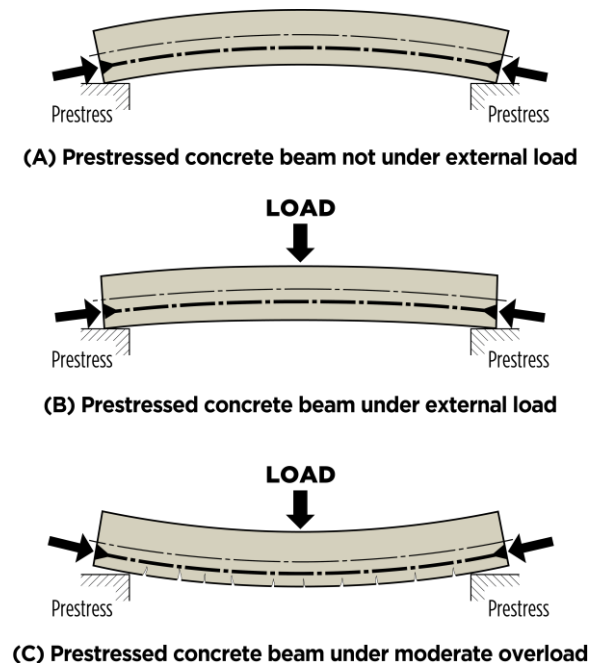
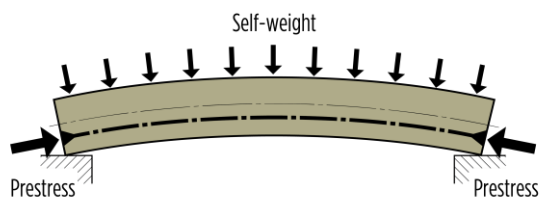

Figure I.20 – Simply Supported Prestressed Concrete Beam under Load

There are a number of special features about the behaviour of prestressed concrete beams (and columns) that should be noted:

- The positioning of the prestressing tendons within a member is very important. Because of the magnitude of the forces involved, minor changes in the location of tendons can have severe consequences. For example, in the beam shown in **Figures I.20(a)** and **I.20(b)**, location of the prestressing tendons closer to the bottom than was intended would cause an increased upward camber on the beam which may be unacceptable, and could even cause tension cracks to open in the top surface, which could be deleterious to the long-term durability of the beam;

- The magnitudes of the stresses in a prestressed member are such that when it is precast it must be handled with considerable care. For example, the self-weight of a correctly positioned prestressed beam will tend to counteract the camber or upwards deflection (**Figure I.21(a)**). Placing a beam in an upside-down position (not unknown) will accentuate the deflection or camber and may even cause the beam to fail (**Figure I.21(b)**). Attempting to lift a beam by other than its designated lifting points may have similar consequences.



(A) Precast prestressed beam correct way up

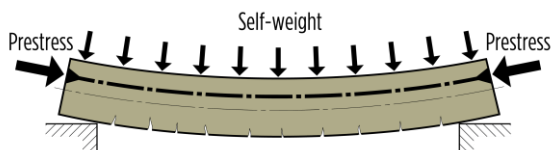

(B) Precast prestressed beam wrong way up

Figure I.21 – Position of a Precast Prestressed Concrete Beam

4.2 PRE-TENSIONING

In a pre-tensioned member, tendons are first carefully positioned within the formwork and the design load or tension is applied to them. Then, whilst tensioned, the concrete is cast around them and allowed to harden until it achieves sufficient strength (usually 32 MPa or higher) to resist the forces to be applied to it. The ends of steel tendons are then released from their restraints and the stress is transferred to the concrete by the bond between the two materials.

The tendons used in pre-tensioning are usually in the form of small-diameter wires or strands (a combination of smaller wires – **Figure I.22**). The diameters of these materials are kept small to increase the surface area available for

bonding with the concrete. Indented wire is also commonly used to further increase bond.

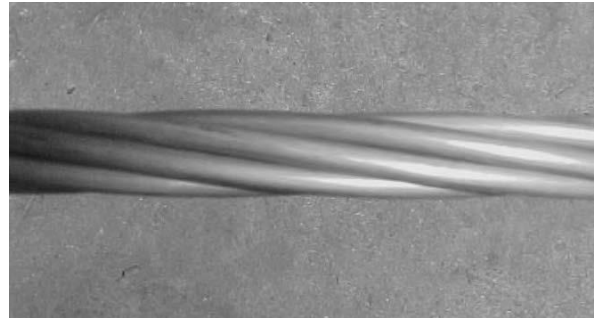

Figure I.22 – Prestressing Strand and Wire

4.3 POST-TENSIONING

When a member is to be post-tensioned, the concrete is first allowed to harden before the steel tendons are stretched or tensioned. They cannot therefore be allowed to bond with the concrete, at least not initially. Usually they are placed in ducts or holes which have been cast in the concrete, although sometimes they are greased and encased in a plastic tube to prevent bond. In other cases, the tendons are fixed to the outside faces of the member.

After the concrete has gained sufficient strength, the wires or cables are tensioned and then fixed or anchored in special fittings cast into the ends of the concrete member. A wide variety of patented fittings and systems are available for this purpose. Typical slab and beam anchorages are shown in **Figures I.23** and **I.24** respectively.



Figure I.23 – Typical Slab Anchorage

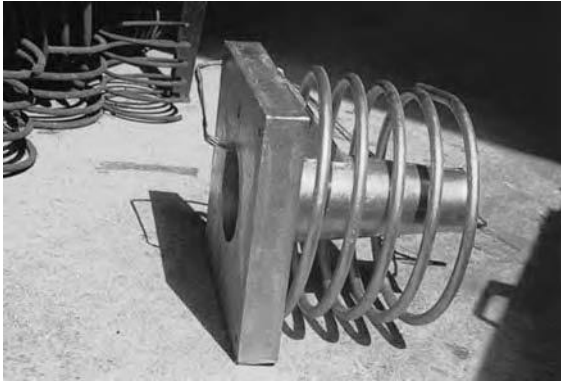

Figure 1.24 – Typical Beam Anchorage

4.4 APPLICATIONS

Although both pre-tensioning and post-tensioning systems are designed to apply prestress to concrete members, there are some practical differences in their fields of application. Pre-tensioning is normally confined to the factory production of repetitive units where the cost of the relatively large abutments or restraints, against which the prestressing jacks operate, can be justified. Alternatively, very strong and robust formwork may be constructed and wires are anchored against its ends.

Post-tensioning is more flexible in its application and may be carried out on-site. It permits the use of curved tendon profiles and is also suited to a wide variety of construction techniques, such as 'segmental construction' and 'stage stressing'. Since stressing is not carried out until the concrete has hardened, the concrete member itself provides the restraint against which the stressing jacks operate (Figure 1.25).



Figure 1.25 – Post-Tensioning Jack Operating at an End of a Concrete Girder

5. BASIC PRINCIPLES OF FIBRE REINFORCED CONCRETE

5.1 TYPES OF FIBRES

Another form of reinforcement of concrete is available with the use of fibres. The more common forms of fibres currently available are discussed in this section but it must be noted that new forms of fibres, including variations in material used to manufacture the fibre, shape and size are being developed all the time.

The common broad material types used in fibres are summarised below:

- Steel;
- Synthetic/Polymer;
- Glass;
- Carbon;
- Natural.

Each of these materials will produce varying properties to the concrete. In addition, the characteristics of fibre reinforced concrete change with varying concretes, fibre materials, shape, size and dose rate.

Steel fibres are the most commonly used fibres for increasing the strength of concrete elements and therefore are described by shape, aspect ratio, length and tensile strength. Some typical shapes for steel fibres are shown in Figure 1.26.

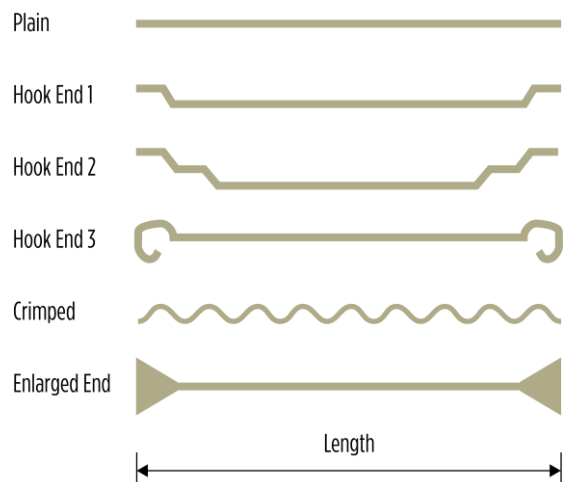

Figure 1.26 – Some Common Steel Fibre Shapes

The aspect ratio of a fibre is defined as the length of the fibre divided by the average cross

section diameter of the fibre. Steel fibre tensile strength typically ranges between 800 MPa and 2000 MPa. Each fibre type and source have a typical design tensile strength measured in accordance with Eurocode or ASTM standards (e.g. ASTM A820 or EN 14889-1). The steel fibre tensile strength, aspect ratio, length and shape all impact on the final concrete hardened properties containing these fibres.

Synthetic fibres have been largely composed of polypropylene or nylon but newer fibres are being developed from other materials such as recycled waste. Fibres may contain polyolefin varieties such as polypropylene or polyethylene terephthalate and other suitable plastics. Synthetic fibres are commonly used to resist spalling of concrete during a fire.

Synthetic fibres come in two main groups:

- Macro Synthetic (also known as Structural Synthetic);
- Micro Synthetic.

Macro synthetic fibres are made from a number of polymers and were originally developed to provide an alternative to steel fibres in some applications. They generally have a high tensile strength and a moderate modulus of elasticity. Unlike polypropylene micro synthetic fibres, they can significantly increase the post-cracking capacity of concrete. The properties of Macro and Micro Synthetic fibres are provided by EN 148892. Macro synthetic fibres come in varying lengths, aspect ratios and degree of surface texture to aid shear connection to the concrete.

Micro synthetic fibres are commonly produced from polypropylene. There are two forms of these fibres:

- Monofilament;
- Fibrillated.

Monofilament fibres are defined by length (typically 20 mm to 60 mm) and generally have diameters of 0.05 mm to 0.3 mm. These fibres are not considered replacement of steel fibres or macro synthetic fibres but have beneficial properties when correctly used in concrete. Some of these properties include reduction of plastic cracking in concrete, some reduction of spalling of concrete subjected to fire and improved impact resistance of concrete.

Fibrillated fibres are defined by length (typically 6 mm to 15 mm) and generally have diameters of 0.030 mm to 0.040 mm. These are beneficial to concrete when correctly used. Some of these properties include reduction of plastic cracking in concrete and significant reduction of spalling of concrete subjected to fire when used at the correct dose rate.

Glass fibres for concrete are generally composed of alkali resistant glass. Glass fibres have been more commonly used in the production of thin lightweight precast panels. In this application higher additions of glass fibre improve the tensile strength and toughness of the panels.

Natural fibres and carbon fibres are less commonly used. Natural fibres may include basalt fibres and various types of plant sourced fibres. Asbestos fibres are also a natural fibre but are no longer used due to safety concerns.

Other types of fibres noted have their own specific properties and impacts on concrete. In all cases the supplier's information on their correct use must be considered before they are specified.

5.2 ACTION OF FIBRES IN CONCRETE

All fibre types can be used in conjunction with standard steel reinforcement to improve the structural and durability performance of a concrete member. It is possible that some varieties of fibre when used in the correct applications can be the only reinforcement in concrete.

Plain concrete generally shows brittle behaviour leading to failure after the first tensile stress crack is formed under load. This property of plain concrete can be enhanced in some applications by using suitable fibres to provide a more ductile behaviour under load.

Steel fibres and some structural synthetic fibres can provide useful tensile restraint and aid more ductile behaviour of loaded structures post cracking. This behaviour is discussed in AS 3600 and reference is made to the residual flexural tensile strength test per Euro standard EN 14651. **Figure I.27** is used in

AS 3600 and EN 14651 to demonstrate the relationship between the load supported by the test beam at various crack opening values (crack mouth opening displacement or 'CMOD').

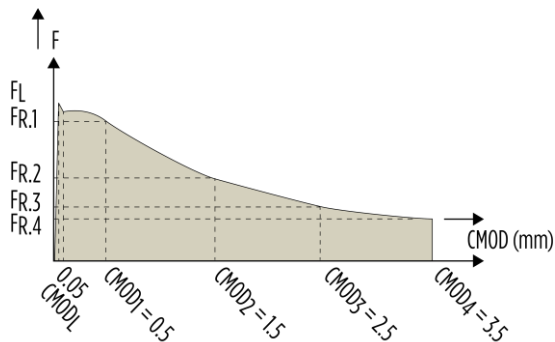

Figure 1.27 – Load Versus CMOD for Residual Flexural Tension

Most types of fibres will reduce the likelihood of plastic cracking in concrete. Their performance at doing this is dependent on the individual product dose rate used. The dose rate for a specific fibre must be discussed with the fibre supplier.

The drying shrinkage of concrete can be reduced through use of steel fibres. In this case optimising the combination of steel fibre dose rate in concrete requires coordination with the concrete mix to achieve suitable workability with this dose rate of fibre.

Steel fibres, macro synthetic fibres and some specific micro synthetic fibres have proven to be useful for improving the impact resistance and abrasion resistance of concrete.

Specific types of micro synthetic fibres have proven very useful in reducing or eliminating spalling of concrete under aggressive fire testing. The concrete mixture should be assessed for performance in a fire to ensure that the correct dose of fibres is used where spalling mitigation is required. Fire testing is carried out in accordance with AS 1530.4.

Significant local and international research into the performance of steel fibres in providing enhancement to the shear resistance of concrete is being carried out. The result of some of this research is reflected in AS 3600. In AS 3600 a design value of the steel

fibre impact on shear resistance of a reinforced concrete member is estimated based on the steel fibre component of the concrete.

In all cases the degree of benefit provided by an individual fibre needs to be assessed and will depend on using an adequate dose of fibres to achieve the targeted enhancement.

5.3 APPLICATIONS FOR FIBRES IN CONCRETE

Fibre reinforced concrete is used in structures with or without the addition of conventional forms of post-tensioning, bar reinforcement or reinforcing mesh. The type of fibres used will depend on the benefit being sought and the economics of the solution.

Common structures that use fibres as part of the concrete reinforcement system in Australia include:

- Industrial pavements;
- Concrete road pavements and roundabouts;
- Precast concrete elements used in tunnel lining;
- Underground shotcrete in tunnel and underground mining applications;
- Sprayed concrete swimming pools in stable foundations;
- Sprayed embankment stabilisation;
- Footpaths and driveways;
- Concrete road barriers;
- Concrete elements where resistance to spalling in a fire is critical.

6. REFERENCES

- 1) AS 3600 – *Concrete structures*
- 2) AS 5100.5 – *Bridge design – Concrete*
- 3) AS 1379 – *Specification and Supply of Concrete*
- 4) AS 1530.4 – *Methods for fire tests on building materials, components and structures. Fire-resistance tests for elements of construction*
- 5) EN 14651:2005+A1:2007 – *Test method for metallic fibre concrete. Measuring the flexural tensile strength (limit of proportionality (LOP), residual*
- 6) EN 14889-1 – *Fibres for concrete, Part 1: Steel fibres definitions, specifications and conformity*
- 7) EN 14889-2 – *Fibres for concrete, Part 2: Polymer fibres – Definitions, specifications and conformity*
- 8) ASTM A820 – *Standard Specification for Steel Fibers for Fiber-Reinforced Concrete*
- 9) ASTM C1116 – *Standard Specification for Fiber-Reinforced Concrete*
- 10) ASTM D7508 – *Standard Specification for Polyolefin Chopped Strands for Use in Concrete*
- 11) Putri EE, Kameswara Rao NSV & Mannan MA, 'Evaluation of modulus of elasticity and modulus of subgrade reaction of soils using CBR test', *Journal of Civil Engineering Research* (2012)

GUIDE TO CONCRETE CONSTRUCTION

T41



CEMENT CONCRETE
& AGGREGATES AUSTRALIA

PART II - Constituents of Concrete

This section provides general information on the types of cement available in Australia and their characteristics and their chemical and physical properties. In addition, it supplements the information on the influence of cement on the properties of concrete given in Part VIII, Section 25 'Properties of Concrete'.

CONTENTS

1. INTRODUCTION	2	6.4 ALKALI OXIDES (K ₂ O, Na ₂ O).....	19
2. TYPES OF CEMENT AND THEIR USES ..	3	6.5 LOSS ON IGNITION.....	20
2.1 GENERAL.....	3	7. SUMMARY	20
2.2 GENERAL PURPOSE CEMENTS.....	3	8. REFERENCES	21
2.3 BLENDED CEMENTS.....	4	9. FURTHER READING	21
2.4 PRINCIPAL CEMENTS USED IN AUSTRALIA.....	5		
3. CHEMICAL PROPERTIES	9	1. INTRODUCTION	
3.1 GENERAL.....	9	Concrete is a generic term that refers to composite material in which aggregates are bound together by a binding agent to form a solid structural product. Typical examples are Portland cement concrete and asphaltic concrete where the binders are Portland cement (paste) and bitumen respectively.	
3.2 GENERAL PURPOSE CEMENT	9	This section describes 'Portland cement' as used in 'conventional' concrete – though the applications of 'Portland cement' concrete have grown remarkably in the last few decades. 'Portland cement', through the hydration reaction, is the fundamental component that determines the performance of conventional concrete and is usually the most expensive component. Its selection and proper use are important in obtaining the balance of properties required for a particular concrete application and in minimising the cost of the concrete.	
3.3 BLENDED CEMENTS.....	11	An understanding of the properties of the available cementitious materials and their influence on the properties of the concrete is important for the proper selection and use of these materials. This understanding requires some familiarity with the chemical and physical characteristics of cement and cementitious materials and of their influence on cement and concrete performance.	
4. PHYSICAL PROPERTIES	12		
4.1 SETTING TIME.....	12		
4.2 HEAT OF HYDRATION/ TEMPERATURE RISE.....	12		
4.3 STRENGTH DEVELOPMENT.....	13		
4.4 VOLUME CHANGE.....	14		
4.5 PERMEABILITY.....	15		
4.6 ALKALINITY.....	15		
4.7 RESISTANCE TO CHEMICAL ATTACK.....	16		
4.8 RESISTANCE TO FREEZING AND THAWING.....	17		
4.9 RESISTANCE TO HIGH TEMPERATURE.....	17		
5. STORAGE, SAMPLING AND TESTING OF CEMENT	18		
5.1 STORAGE	18		
5.2 SAMPLING AND TESTING.....	18		
6. APPENDIX – MINOR CONSTITUENTS OF CEMENT	18		
6.1 GYPSUM.....	18		
6.2 FREE LIME (CaO)	19		
6.3 MAGNESIA (MgO).....	19		

2. TYPES OF CEMENT AND THEIR USES

2.1 GENERAL

Cement is a term used to describe a wide variety of organic and inorganic binding agents. The most widely used are those known as hydraulic cements – finely ground inorganic materials which possess a strong hydraulic binding action, i.e. when mixed with water they harden, in the absence of air, to give a strong, stable and durable product. (**NOTE:** *Hydraulic cements may also harden under water.*)

Hydraulic cements manufactured in Australia fall into two broad classes – general purpose cements and blended cements. The latter are mixtures of general purpose cement with other materials which either (a) possess inherent cementitious properties – e.g. ground granulated blast-furnace slags (hereinafter referred to as slag), or (b) which are pozzolanic in nature – i.e. they react with lime in the presence of water to form cementitious compounds. The most commonly used pozzolans are fly ash and silica fume.

Cements are manufactured in Australia to comply with the requirements of AS 3972. Seven different types of cements are covered by this Standard, three of which are designated as 'General Purpose' and four as 'Special Purpose' cements. The term 'Portland cement' as noted in AS 3972 refers to cement made using clinker and gypsum only and the descriptor is no longer relevant in most cases. For the remainder of this section, the term 'general purpose cement' will generally be used.

The table at the end of this section lists the common cements and their typical applications. In addition, it covers a number of other hydraulic cements, some of which are produced locally and some of which are imported. The use of these additional materials is limited but they provide valuable additions to the range of binding agents available.

2.2 GENERAL PURPOSE CEMENTS

General purpose cements were known originally as Portland cement. 'Portland cement' was patented in 1824 in England and has evolved since then. The term 'Portland' derives from the colour of the product which is similar to natural rocks found in the Portland region in England. 'Portland cement' is manufactured by carefully proportioning a mixture of calcium carbonate, alumina, silica and iron oxide which, when calcined and sintered at high temperatures (about 1,400°C), yields a new group of minerals which react with water to form cementitious compounds. The raw materials most commonly used in making cement are calcium carbonate (in the form of limestone, coral or chalk); silica, alumina and iron oxide (often from clay and shale). Sources of silica (such as sand), of alumina (such as bauxite), and iron oxide (such as iron ore) may also be used as supplements if the other materials are deficient. Effectively, cement manufacture involves a set of (stable) natural minerals being converted into a new set of (less stable) synthetic minerals. These new minerals are described (hypothetically) as:

- Tricalcium silicate: C_3S – about 60% of clinker;
- Dicalcium silicate: C_2S – about 20% of clinker;
- Tricalcium aluminate: C_3A – about 10% of clinker;
- Tetracalcium aluminoferrite: C_4AF – about 10% of clinker.

The properly proportioned raw materials are inter-ground to produce a finely divided 'raw meal' for transfer to the kilns. The 'raw meal' is heated in rotary kilns at temperatures from 1,300 to 1,500°C where the components react together and partially fuse to form 'clinker' – hard balls of ceramic-like material. The application of heat energy causes chemical reactions to take place which results in the conversion of the original minerals to new minerals. The relatively coarse clinker can be stored in sheds or silos as it is quite stable. It may also be shipped to distant destinations without any significant effect on the performance of the cement ultimately made from the clinker.

To manufacture cement suitable for use in concrete, the clinker plus a small amount (about 5%) of gypsum (calcium sulfate) is ground in a 'cement mill' to a fine powder. Mineral addition materials may also be added at this time – with AS 3972 allowing 'up to 7.5%' of a suitable mineral addition to be added. Typically, the mineral addition material used is limestone. These materials are milled together in either large ball mills (100-150 tonnes/hour capacity) or vertical roller mills (typically about 200 tonnes/hour capacity). The lower energy consumption of vertical roller mills is making them the 'mill of choice' in modern cement plants.

In addition to gypsum, small quantities of other materials may be inter-ground with the clinker – generally to improve mill throughput. These 'grinding aids' act in various ways – typically preventing the cement particles from adhering to one another. This has the added advantage of limiting or preventing an issue known as 'pack set' where cement powder stored in large quantities may form soft lumps over time. These lumps can cause blockages when transferring the powder from silos and/or ships.

Chemicals known as 'cement improvers' may also sometimes be added during milling. These often have limited benefit.

The previously mentioned 'mineral additions' are used primarily to lower the CO₂ intensity of cement – simply by diluting the clinker content. Note that fly ash and/or slag may also be considered as 'mineral additions' when used at 'up to 7.5%'.

The gypsum added during milling has a critical effect on cement performance. Cement can be made without gypsum, but such cement would suffer from a condition known as Flash Set when water was added to it. Flash Set occurs when one of the cement minerals (C₃A) reacts immediately with the water. The C₃A hydration product causes the mix to immediately stiffen, making the concrete or mortar unable to be placed or compacted. The gypsum, which has been partially converted to 'Plaster of Paris' when heated during the milling process, partially dissolves releasing sulfate ions that coat the C₃A mineral and prevents it hydrating

for about 12 hours, by which time the mortar or concrete has been placed and finished.

In the 2010 review of AS 3972, a new general purpose cement was included in the Standard. This cement, a General Purpose Limestone Cement (Type GL), 'may contain limestone alone or in combination with minor additional constituents (maximum 5%) of 8-20% by mass of the total cement.' This cement type was introduced to (a) allow producers to reduce the CO₂ intensity of cement substantially, and (b) to facilitate further research into higher (than 7.5%) levels of mineral addition in Type GP cement through making trial cements with >7.5% (and up to 20%) mineral addition compliant with AS 3972. Little or no commercial production of Type GL cement is currently occurring in Australia.

2.3 BLENDED CEMENTS

In AS 3972, blended cements are defined as hydraulic cements containing general purpose cement and a quantity, greater than 7.5%, of a supplementary cementitious material (SCM) – slag or fly ash (or both) and/or up to 10% silica fume. The SCM's approved in AS 3972 for blending with general purpose cement are fly ash, slag and silica fume conforming to the requirements of the relevant parts of AS 3582. By extension, mixtures of general purpose cement and other reactive ingredients can be considered to be blended cements also but are not presently included in AS 3972.

As might be expected, the range of properties which can be achieved with blended cements is quite wide, depending on the nature of the SCM and the proportions in which the constituents are mixed. In practice, however, the difference in properties between Type GP (general purpose cement) and Type GB (general purpose blended cement) is not necessarily huge as both are formulated to be used in general building construction. Indeed, there is very little concrete used in general building construction today which does not contain a proportion of fly ash and/or slag.

2.4 PRINCIPAL CEMENTS USED IN AUSTRALIA

General – The physical and chemical properties specified in AS 3972 are summarised in **Table 1.1**. As may be noted, there are few restrictions on the constituents of general purpose and blended cements. AS 3972 is largely a performance-based standard in which the cements are described in terms of required performance characteristics rather than just their chemical composition.

As the raw materials used to produce general purpose and blended cements can vary from locality to locality, the chemical compositions of cements may also be variable. Nevertheless, with modern technology, it is possible to produce cements from these materials which have very similar physical and performance

characteristics. AS 3972 specifies only aspects of chemical composition which are necessary to ensure satisfactory performance – e.g. upper limits on the MgO (in clinker) and SO₃ contents to guard against excessive long-term volumetric expansion of the hydrated cement paste, plus a limit on chloride ion content to assist in managing corrosion in concrete structures containing embedded steel.

Type GP-General Purpose Portland Cement

– Type GP cement is intended for use in most forms of concrete construction and should be specified where the special properties of other types (such as high early strength, low heat of hydration, or resistance to sulfates) are not required.

Table 1.1 – Physical and Chemical Properties for Different Cement Types (AS 3972)

AS 3972 requirements	Type of cement						
	GP	GB	GL	HE	SL	SR	LH
Physical properties ^(a)							
Setting time							
Max.(h)	6	10	10	6	10	10	10
Min. (minutes)	45	45	45	45	45	45	45
Soundness							
Max. expansion (mm)	5	5	5	5	5	5	5
Compressive strength (MPa)							
Min. at 3 days	-	-	-	25	-	-	-
Min. at 7 days	35	20	20	40	(b)	(b)	10
Min. at 28 days	45	35	35	-	(b)	(b)	30
Peak temperature rise							
Max.(°C)	-	-	-	-	-	-	23
Drying shrinkage							
Max.(microstrain) 28 days	-	-	-	-	750	-	-
Sulfate expansion							
Max.(microstrain) 16 weeks	-	-	-	-	-	750	-
Chemical limitations ^(a)							
MgO in clinker							
Less than (%)	4.5	4.5	4.5	4.5	4.5	4.5	4.5
SO ₃ content							
Max.(%)	3.5	3.5	3.5	3.5	3.5	3.5	3.5
Chloride ion							
Max.(%)	0.1	0.1	0.1	0.1	0.1	0.1	0.1

NOTE: (a) When determined in accordance with the methods set out in AS 2350;
(b) Strengths shall comply with the Type GP or Type GB requirements depending on the cement composition.

Type GP cement may contain up to 7.5% of approved mineral additions. Acceptable mineral additions in AS 3972 include limestone containing not less than 80% by weight of CaCO₃ and fly ash and slag complying with the requirements of AS 3582. Such additions, in the proportions specified, assist the cement manufacturer in the production of a more economical and more uniform product and lower the CO₂ intensity of the final product. Mineral additions are inter-ground with clinker and cannot be added as a separate component.

The performance requirements for Type GP cement are those necessary to ensure satisfactory performance with concrete used in general applications. Thus, for example, its minimum strengths at 7 and 28 days are higher than those for the Special Purpose cements (except Type HE), but it is not required to have the special properties associated with the Special Purpose cements e.g. low heat of hydration or improved sulfate resistance.

Type GB-General Purpose Blended Cement – Type GB cement may be seen as a companion to Type GP cement, being intended for use in most forms of general concrete construction.

By varying the proportions of general purpose cement and fly ash, slag and silica fume in blended cements, it is possible to produce cements with a wide range of performance characteristics. Whilst the minimum strengths specified for Type GB cements are lower than those for Type GP (in recognition of their generally lower rates of strength gain), it is not uncommon for their ultimate strengths to equal or exceed those with Type GP cement, provided moisture (e.g. through proper curing) is available for a sufficient length of time.

Type GB cement containing silica fume, which is often intended for use in applications where high strengths are sought, will generally achieve relatively high early-age and 28-day strengths, but the later age strengths are typically not much higher than those achieved at 28 days. The allowable silica fume content is limited to 10% maximum as higher levels may lead to concrete with poor workability properties.

Type HE-High Early Strength Cement – As the name implies, Type HE cement develops strength more rapidly than Type GP or Type GB cements. Rapid strength development should not be confused with rapid setting, the latter being the rate at which the cement paste loses its plasticity. Most cements have somewhat similar setting times but may have significantly different rates of strength gain.

High early strength performance is achieved through grinding the cement finer which promotes more rapid hydration. It lends itself to applications where rapid strength development is required; for example, where formwork has to be removed as soon as possible (precast concrete), or where early strength is required so that further construction can proceed (post-tension concrete). The rapid strength development is usually accompanied by a higher rate of heat evolution. Type HE cement should not generally be used in thick concrete sections or in mass construction. On the other hand, its use in construction under cold weather conditions may be beneficial.

Type LH-Low Heat Cement – Type LH cement is designed for use where limitation of the heat of hydration (and hence the temperature rise in concrete) is necessary to avoid unacceptable thermal stresses. These situations may occur in mass concrete structures or in thick structural elements. Low-heat cement may be a general purpose cement or a blended cement provided it meets the requirements for temperature rise specified in AS 3972.

Low heat characteristics are achieved by reducing the content of the more rapidly hydrating compounds in cement (C₃S and C₃A) or by blending with supplementary cementitious materials. These, generally, will result in a lower rate of strength development. Blended cements have inherent advantages in minimising heat evolution because of their lower rates of strength gain, and act by diluting the general purpose cement. Typically, 40% fly ash and 65% GGBFS are used to make a Type LH cement.

Type SL-Shrinkage Limited Cement – Some major specifications in Australia require the use of Type SL cement as a means of controlling the shrinkage of concrete used in significant

concrete structures. Within the scope of AS 3972, a cement characterised in terms of its shrinkage performance was required to reflect/cover these industry requirements.

Type SL cement is intended for use where emphasis is placed on drying shrinkage and crack control in concrete structures (e.g. road pavements and bridge structures). Type SL cement may be a general purpose or a blended cement provided it meets the drying shrinkage limit specified in AS 3972 (see **Table 1.1**). With general purpose Type SL cements, a coarser grind than that used for Type GP is typically used.

Type SR-Sulfate Resisting Cement – Type SR cement is intended primarily for use where resistance to ground waters and other external water sources containing sulfates in solution is required. The relationship between the sulfate resistance of general purpose cement and its tricalcium aluminate (C_3A) content is well established. Portland cement containing less than 5% C_3A is classified as sulfate resisting cement in many codes and standards for cement worldwide, including Australia until recently.

Studies have shown that cements potentially containing less calcium hydroxide on hydration perform well with sulfate exposure, e.g. certain blended cements. A limit on C_3A content for these cements is neither appropriate nor applicable. Therefore, as a performance-based specification, AS 3972 replaced the limit on C_3A for sulfate resisting general purpose cement with a performance test involving the measurement of expansion of mortar bars after exposure in a sulfate solution. A performance limit (maximum expansion) suitable for a compliant Type SR cement is noted in **Table 1.1**. This limit was developed by benchmarking the performance of Australian Type SR cements with recognised and accepted sulfate resisting cements from other countries.

Type SR cement may be a general purpose cement or a blended cement provided it meets the sulfate expansion limit specified in AS 3972. The minimum strength requirements in AS 3972 for Type SR cements (as noted in **Table 1.1**) are required to be equivalent to

those for either general purpose or blended cements – depending on the composition chosen for the particular Type SR cement.

Off-White and White Cements – The grey colour of cements is due mainly to the presence of iron in the cement (in the ferrite phase — tetracalcium aluminoferrite, C_4AF). By lowering the iron content, light-coloured cements can be produced. This is achieved by using raw materials low in iron and manganese oxides. Because of more costly raw materials and special requirements in manufacturing, Off-White and White cements are more expensive than the more widely used grey cements.

The composition of Off-White and White cements is characterised by relatively high C_3A contents (9 to 14%) and low C_4AF contents (3% for Off-White and 0.3 to 0.4% for White cements).

Off-White and White cements are used principally for architectural purposes. Since relatively high cement contents are normal in this application, dense concretes of low water/cement ratio, which are required properties for durability, can be obtained. However, because of the high C_3A content of this type of cement it should not be used in low heat or sulfate resisting applications.

There is no specific Australian Standard for these types of cement, but Off-White cement is manufactured in Australia to meet the requirements for Type GP or Type HE in AS 3972. Off-White and White cements imported into Australia are typically required to comply with AS 3972.

Coloured Cements – Most coloured cements consist of cement and inorganic pigments inter-ground or mixed together, although some are produced from clinkers having a characteristic colour derived from the raw materials or the manufacturing process.

In the production of coloured cements with pigments, the base is either grey cement or the more costly Off-White or White cement. Grey cement is normally used to produce dark colours.

To be suitable for use with cements, pigments are required to be colour-fast under exposure to

light and weather and of a chemical composition such that the pigment is neither affected by the cement, nor detrimental to its setting, hardening, and durability characteristics. Pigments should not contain salts that may cause efflorescence. Black, red and yellow pigments are usually finely-ground iron oxides of different composition, while white pigments are usually titanium dioxide.

Masonry Cement – Masonry cement is intended mainly for use in mortar for brick, stone and concrete block construction. It is a finely ground mixture of general purpose cement clinker, gypsum (calcium sulfate) and suitable inorganic materials such as hydrated lime, limestone and pozzolans. Air-entraining agents, water-reducers (plasticisers) and water-repellent substances may also be incorporated. Masonry cement is produced in Australia to meet the requirements of AS 1316.

It is characterised by producing mortars of high workability and high water retentivity, but which have a lower rate of strength development than those made from only general purpose cement. These characteristics make masonry cement especially suitable for masonry work, but it is entirely unsuitable for any form of structural concrete (plain, reinforced or prestressed).

Oil-Well Cement – Oil-well cement is used in the petroleum industry to grout oil and gas wells. In these applications, the cement slurry must remain sufficiently fluid (at temperatures ranging from normal to about 200°C and under pressures ranging from atmospheric to about 125 MPa) for the several hours needed to pump it into position. It should then harden fairly rapidly. It may also have to resist corrosive conditions resulting from sulfur gases or waters containing dissolved salts.

Oil-well cements are modified general purpose cements that are designed to serve this need. They consist of coarsely ground cement of low C₃A content, with or without a retarder.

The properties required of oil-well cements are set out in the American Petroleum Institute Standard API STD-10A '*Specification for Oil-well Cements and Cement Additives*'. They are subdivided into six classes each applicable to a

specified range of well depths, temperature and corrosion conditions.

Special methods of testing oil-well cements for thickening times and strength under conditions of high temperature and pressure have been developed and are covered by the American Petroleum Institute Standard API-RP 10B '*Recommended Practice for Testing Oil-Well Cements and Cement Additives*'.

High Alumina Cement (HAC) – HAC is very different from general purpose cement in its chemical composition and in its characteristics. The difference is derived from the raw materials from which it is made – principally bauxite and limestone. The product resulting from the chemical combination of these two materials is a cement having a high alumina (Al₂O₃) content and a low lime (CaO) content as compared with general purpose cement. In some literature, HAC is called 'calcium aluminate cement' or 'Ciment Fondue', but it is more commonly known as high alumina cement. It is all imported into Australia.

HAC is characterised by a very rapid rate of strength gain which results in very high early strengths and high rates of heat evolution. The latter characteristic allows hardening to take place at relatively low temperatures but prevents its use in mass concrete or in other applications where high rates of heat evolution may cause problems. HAC is resistant to attack by sulfates and sulfate solutions, a property which, combined with its high early strength, has led to its use in factory floors and similar applications. It also finds applications in refractory concrete because of its resistance to very high temperatures.

However, HAC may suffer a substantial loss of strength in conditions which are both warm (above, say, 25°C) and humid. Under these conditions, a chemical process known as 'conversion' takes place during which some of the hydrated compounds of the hardened cement paste convert to other compounds of smaller volume. This results in a cement paste with significantly reduced strength.

The rate at which 'conversion' occurs depends on the moisture condition and temperature of the concrete. Where moisture is present and

temperatures are above 25°C, the rate is fairly high. Water/cement ratio also affects the rate of ‘conversion’ – the greater the original water/cement ratio, the faster the rate of ‘conversion’ and the lower the converted strength. External chemical agents may also affect the rate of ‘conversion’.

The use of HAC in warm humid environments should therefore be approached with great caution because of the possibility of ‘conversion’ and loss in concrete strength.

If general purpose cement is added to HAC, the setting time of the mixture is significantly less than that of either product used alone. The exact proportion at which the most rapid setting is obtained varies with particular batches of HAC and general purpose cement.

Mixtures of the two cements are used in pastes, mortars and concretes, for applications requiring quick setting and the development of reasonable strength at a very early age, e.g. for sealing leaks or stabilising rock. However, in general, the faster the setting time the lower the ultimate strength obtained. Caution should therefore be exercised in applications where the strength of the concrete is an important element of its performance.

3. CHEMICAL PROPERTIES

3.1 GENERAL

The chemical composition of Portland cements, high alumina cements, slags and pozzolans is dominated by three elements – namely calcium, silicon and aluminium. The proportions of these elements, expressed as oxides, are shown in the ternary diagram in **Figure 1.1**.

(NOTE: Each axis of the diagram represents 0-100% of the respective oxides.)

3.2 GENERAL PURPOSE CEMENT

Chemical Composition – The chemical composition of most modern general purpose cements falls within the ranges given in **Table 1.2**. The composition for individual cements depends on the type of cement being manufactured and the composition of the raw materials being used. Given the wide range of

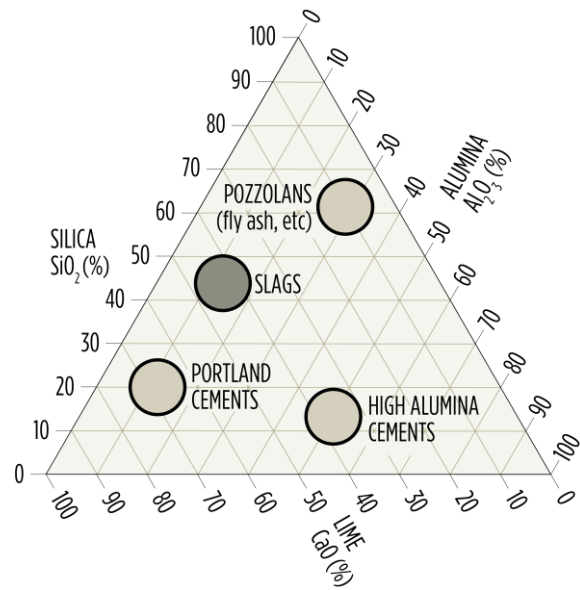

Figure 1.1 – Relative Chemical Compositions of Cementitious Products

raw materials found in Australia, it is not usual for all cements, even of the same type, to have exactly the same chemical composition.

Table 1.2 – Typical Oxide Content Ranges for General Purpose Cements

Oxide	Content (mass %)
Lime (CaO)	60 – 67
Silica (SiO ₂)	17 – 25
Alumina (Al ₂ O ₃)	3 – 8
Iron Oxide (Fe ₂ O ₃)	0.5 – 6.0
Magnesia (MgO)	0.1 – 4.5
Alkalies (Na ₂ O + K ₂ O)	0.5 – 1.3
Titania (TiO ₂)	0.1 – 0.4
Phosphorus (P ₂ O ₅)	0.1 – 0.2
Sulfate (expressed as SO ₃)	1 – 3

‘Portland cement’ includes four major (hypothetical) minerals which are formed during the clinkering process. These are identified as: tricalcium silicate (C₃S), which exists in clinker in the impure form (and is also known as alite); dicalcium silicate (C₂S) (which is also known as belite); tricalcium aluminate (C₃A); and the ferrite phase which exists as a compound close

in composition to tetracalcium aluminoferrite (C₄AF).

Each of these four minerals (phases) exists in several different crystal forms exhibiting some variation in properties. The main properties of the four phases are summarised in **Table 1.3**. In addition, some 'minor' constituents will be present in relatively small amounts – e.g. gypsum, alkali oxides and magnesia. Further details of these constituents are provided in the Appendix to this section.

Table 1.3 – Properties of the Mineral Constituents of General Purpose Cement

Mineral Phase	Characteristics	Potential Heat of Hydration* (J/g)
C ₃ S	Light in colour; Hardens quickly with evolution of heat; Gives early age strength.	500
C ₂ S	Light in colour; Hardens slowly; Gives later age strength.	250
C ₃ A	Light in colour; Sets quickly with evolution of heat; Enhances strength of the silicates.	850
C ₄ AF	Dark in colour with little cementing value.	400

NOTE: * This potential is not reached in cement hydration. The heat developed by a cement at any particular age is governed by the rate of hydration.

Reaction with Water – When cement is mixed with water, a series of chemical reactions – hydration reactions – take place which result in the formation of new compounds and the progressive hardening of the cement paste. Evolution of heat and the development of compressive and tensile strength within the paste occur with the passage of time. The strength development is a consequence of the

formation of calcium silicate hydrates and calcium aluminate hydrates which become the 'glue' that binds the aggregate materials to form concrete. There are two by-products to these hydration reactions, namely heat (as noted above) and lime (calcium hydroxide). Calcium hydroxide is present in significant quantities (50-100 kg/m³) in most concrete mixes.

When water is added, the resulting hydration of the tricalcium aluminate (C₃A) is moderated by the gypsum which is added to the cement to control its setting behaviour. The immediate reaction between the C₃A and gypsum produces needle-like crystals of the mineral 'ettringite'. It is this ettringite layer on the surface of the C₃A grains which retards the hydration of this mineral giving a 'dormant period' in which the concrete remains plastic and in which the silicate minerals begin to react.

After some hours, further hydration of the C₃A results in the conversion of the ettringite into a monosulfate and a solid reaction product, approximated by the formula C₄AH₁₃.

Figure 1.2 provides a schematic representation of the relevant chemical reactions with a typical time scale demonstrating the formation of the paste structure that develops over time. Note also the graphical representation of the reduction in paste porosity as the setting and hardening progress.

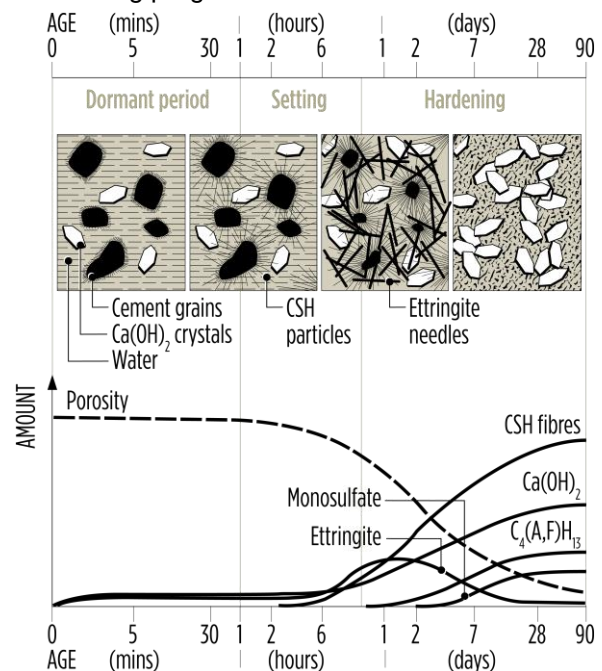

Figure 1.2 – Schematic Representation of the Hydration Reaction – Timing and Reactions Products^{1.1}

The rates of the reactions and the nature and amounts of the products formed depend on (1) the chemical composition of the cement, (2) the temperatures at which the reactions take place, and (3) whether or not chemical admixtures are present in the mixture.

After setting has taken place, the hydration reaction continues. To facilitate this reaction, water is taken from the capillary pores to hydrate the previously unreacted cement. This loss of water causes shrinkage known as autogenous shrinkage. Autogenous shrinkage occurs in the paste and its effect on overall concrete shrinkage is limited by restraint by the aggregate. Typically, the autogenous shrinkage value in concrete is about 50 microstrain.

3.3 BLENDED CEMENTS

Chemical Composition – As noted earlier, blended cements contain, in addition to general purpose cement, either slag, fly ash, silica fume or a combination of these SCM's. The nature of these SCM's will be discussed in detail in Section 2 of this Guide.

When SCM's are used to manufacture blended cements, the final cement product may be obtained either by (1) inter-grinding the SCM(s) with the clinker and gypsum, or (2) (post) blending the SCM(s) with general purpose cement. For a blended cement to meet the requirements of AS 3972, this manufacturing process needs to be carried out in a 'cement plant'. Typically, slag blends are more likely to be manufactured using inter-grinding while fly ash blends are more likely to be manufactured by post-blending.

(NOTE: In Australia, most concrete plants have separate silos of general purpose cement and SCM(s) and the concrete producer can make a large range of mixes with varying SCM types and proportions. When blending is done in a concrete plant the resultant 'blended cement' does not meet the requirements of AS 3972. However, the resultant concrete would be expected to have the same performance as if a blended cement with the same proportions was used.)

For fly ash blended cements, the usual proportion of fly ash used is in the range

20-30%. For Type LH applications, 40% fly ash may be used.

With slag blended cements, Normal Class concrete mixes would typically use a blend containing about 30% slag. For some Special Class mixes and for Type LH and high durability requirements, a blend containing about 65% slag is typically used.

Silica fume is rarely used in the manufacture of Type GB cements in Australia. In countries where it is used, the blend would typically contain 8-10% silica fume.

Reaction with Water – When mixed with water, the cement component of blended cements hydrates to produce calcium silicates and calcium aluminates in a manner analogous to that of hydrating general purpose cement. However, there are some important differences. Firstly, with pozzolanic materials such as fly ash and silica fume, it is the calcium hydroxide produced during the hydration of the general purpose cement which reacts with the silica in the pozzolan to form additional calcium silicate hydrates. These reaction products are similar in structure to those produced by hydrating cement. The lime-silica hydration reaction is much slower than the hydration of cement and blended cements containing pozzolans tend to have lower strengths at early ages than cement-only mixes. They also have lower heat of hydration.

Secondly, with slags, the calcium hydroxide acts as an activator as well as participating in the hydration reactions. In this case also, calcium silicate hydrates and calcium aluminate hydrates are formed. Since slags are themselves weakly cementitious, the reactions will be somewhat faster than the lime-pozzolan mixes but are still slower than cement-only mixes. Blended cements made with slag can be expected to have lower rates of early-age strength gain. However, allowance for this can be made in the manufacture of the blended cement (e.g. by finer grinding) and in the curing of the concrete to ensure suitable strength development so that required 28-day strengths are achieved. At later ages, the strengths of blended cement mixes will generally exceed those of cement-only mixes.

4. PHYSICAL PROPERTIES

4.1 SETTING TIME

When mixed with water, general purpose and blended cements form a plastic workable paste which progresses through setting to eventual hardening. Setting time is the period during which the cement paste stiffens and loses its mobility. Arbitrarily defined initial and final setting times are used as a practical basis for ascertaining the end of the workability period and the onset of hardening.

Initial Set – For cement, it is the point at which the paste reaches a certain degree of stiffness. The time required for the paste to reach 'initial set' is known as the 'initial setting time'. It is one of the major influences determining the length of time for which mortar and concrete remain plastic and workable. To ensure that mortars and concretes do not stiffen or set too early, a minimum initial setting time for general purpose and blended cements is specified in AS 3972.

Final Set – For cement, it is the point at which the paste may be regarded as a rigid solid, is no longer workable and after which time it begins to develop measurable strength. The time required for the paste to reach 'final set' is known as the 'final setting time'. A maximum value is specified in AS 3972.

The initial and final setting times are determined using the test procedure set out in AS 2350.4 which measures the penetration of a needle into a (cement and water) paste of specified consistency. When the needle fails to penetrate the paste to a specified depth within the specified time, the cement is said to have achieved its 'initial set'. Final set is said to have taken place when the needle fails to penetrate the paste to a depth of 0.5 mm.

The setting times for cement paste are not directly applicable to concrete. They are determined on a cement paste and under controlled conditions (including temperature). Concrete setting times are affected by the water content of the concrete mix, the temperature, whether or not the concrete incorporates admixtures and, if so, their type and dosage.

4.2 HEAT OF HYDRATION/ TEMPERATURE RISE

The heat of hydration of cement is the heat liberated as the cement and water react. The amount of heat liberated over time, and the rate at which this occurs is dependent on the cement quantity and type, water/cement ratio and temperature. In general, the rate of heat liberation parallels the rate of strength increase. This rate is usually high during the first two to three days after mixing and then subsides appreciably.

Heat is liberated during the hydration of the cement as the cement minerals adopt a lower-energy condition – resulting in a rise in temperature. Temperature-rise/ age relationships of various cements are shown in **Figure 1.3**. In most concrete construction, heat is dissipated from the concrete and large rises in temperature do not occur. However, in (low surface area) structures such as massive foundations, dams, and thick structural elements too great a temperature differential between the core and the surface may lead to thermal cracking. (**NOTE:** *The core is hot and expanding while the surface is cooling and contracting leading to the development of tensile stresses within the element.*)

Limiting the temperature rise in concrete is important to avoid thermal cracking. It is generally required that the temperature differential be limited to a maximum of 20°C.

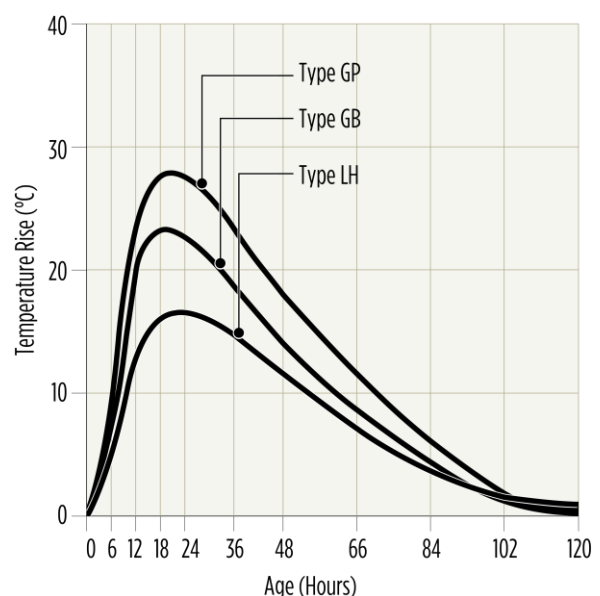

Figure 1.3 – Typical Temperature Rise with Age of Cement Mortars – Semi Adiabatic Calorimeter (AS 2350.7)

Cements with 'low heat' characteristics are produced for use in 'low heat' applications.

Measurement of heat of hydration using the heat of solution method has been used to characterise cements by many countries. While this method determines with good accuracy the total heat of hydration at seven days and longer, it gives no indication of the actual temperature rise under practical conditions or, more importantly, at early age when the maximum temperature rise is likely to occur. Further, the method is not suitable for blended cements for which other methods are now available, e.g. Langavant method.

AS 3972 specifies/characterises low heat cement by the peak temperature rise (**Table 1.1**) measured on a standard cement mortar under semi-adiabatic conditions. **Figure 1.3** shows typical temperature-rise/age curves for various types of cement.

Peak temperature rise is determined in accordance with AS 2350.7. This test method is based on a French test known as the Langavant method. It is modified to put the emphasis on measurement of temperature rise allowing, as an option, the calculation of heat of hydration, if required.

4.3 STRENGTH DEVELOPMENT

On addition of water, the cement minerals hydrate forming mainly hydrates of calcium silicate and calcium aluminate and calcium hydroxide as a by-product. The hydration involves an increase in the volume of the solids in the mix and growth of the gel binds particles, bringing about stiffening of the cement paste (i.e. setting). Further hydration decreases the porosity of the set paste, thereby increasing its strength. The rate of gain in strength of the set paste (strength development) is at its maximum rate at early ages, and gradually decreases with time (**Figure 1.4**). Ultimate compressive strength may take several years to achieve, but for practical purposes 28-day strengths are used as indicators of the 'final' strength – an approach taken and specified in cement and concrete Standards all over the world.

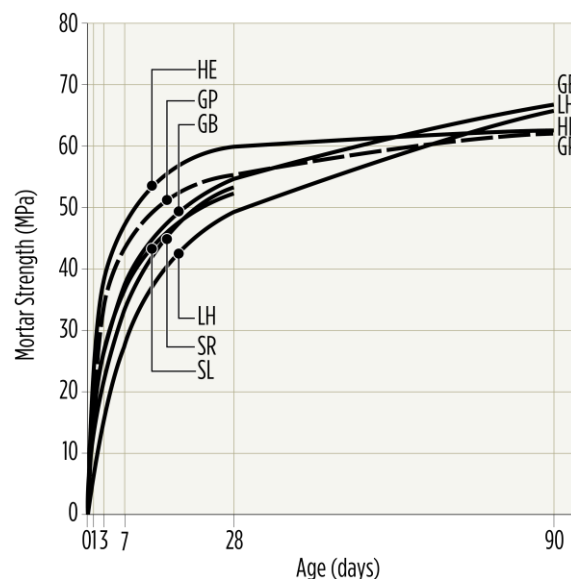

Figure 1.4 – Typical Cement Mortar Strength Development with Age (AS 2350.11)

The rate of strength development as cement hydrates is influenced by both the chemical composition and fineness of the cement. The rate of strength development of blended cements is dependent on the nature and proportion of the component materials, i.e. the amount, type and properties of the cement and the properties of the fly ash, slag or silica fume. As mentioned earlier, fly ash and slag blended cements gain strength more slowly than cement-only mixes at early ages, but they exhibit more strength gain over a longer period, particularly if moisture is available to support curing for a sufficient time. On that basis, the ultimate strength of blended cement mixes is generally higher than that obtained if the same general purpose cement was used alone (**Figure 1.5**).

The compressive strength of general purpose and blended cements as required in AS 3972 is determined by compressive strength tests on mortar prisms using a standard mortar (1:3 cement-sand mixture with a 0.5 water/cement ratio) as defined in AS 2350.12. The actual strength testing is conducted in accordance with AS 2350.11.

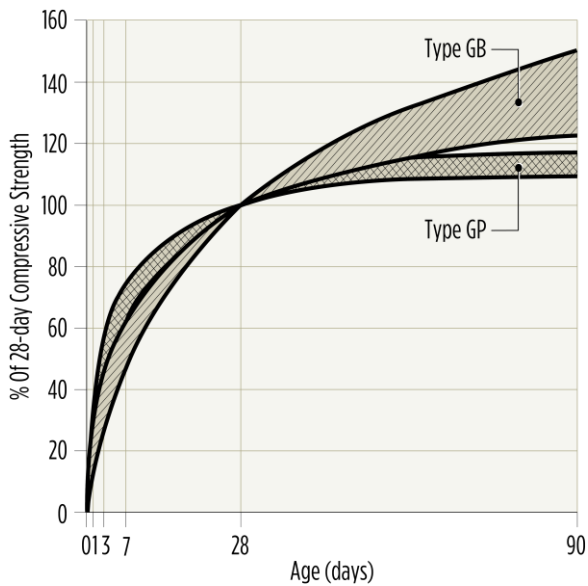

Figure 1.5 – Development of Concrete Strength with Age – Type GP versus Type GB

4.4 VOLUME CHANGE

General – A change in the volume of the hardened paste may be caused by chemical reactions, following for example, attack by aggressive solutions (see 4.7); or by physical factors, such as changes in the moisture content or in the temperature of the paste.

Volume changes due to variations in moisture content (shrinkage) and to variations in temperature (thermal expansion and contraction) are discussed below.

Shrinkage – Variations in the moisture content of cement paste are accompanied by volume changes: drying causes volume decrease, i.e. drying shrinkage; while wetting causes volume increase, i.e. swelling or expansion. A schematic description of volume changes in cement paste due to alternate cycles of drying and wetting is given in **Figure 1.6**. It can be noted that maximum shrinkage occurs on the first drying of the paste and that a considerable part of this shrinkage is irreversible; part of the reduction in volume is not recovered on subsequent rewetting. During successive repetitions of wetting and drying, the process becomes reversible, depending on the structure of the paste and on the relative durations of the wetting and drying periods. Since shrinkage is caused by water loss, it is affected by external factors that affect drying, such as temperature,

humidity and air movement. Shrinkage is also affected by some properties of the cement.

Although it is generally accepted that the composition of cement can affect drying shrinkage, the effect is not completely apparent. The C_3A and alkali content have been observed to have a measurable effect. In addition, the effects of C_3A and alkali content on shrinkage are influenced by the sulfate content of the cement, i.e. shrinkage of cements of the same C_3A content differs for different sulfate contents.

(NOTE: When determining the optimum gypsum/sulfate content for a cement, the cement manufacturer measures the effect of varying gypsum/sulfate levels on strength, setting time and shrinkage and sets the final gypsum/sulfate level at the point where the best performance is obtained.)

For many years, major project specifications in NSW in particular have specified cement composition and/or performance as a means of managing shrinkage of concretes to be used in certain structures – such as road pavements and bridges. It was recognised, however, that there are other cements that have performed well in low shrinkage concrete applications. This led to the development of a cement characterised in terms of its shrinkage performance – Shrinkage Limited Cement (Type SL) and development of a test method to measure the ‘shrinkage performance’ of cements. This mortar test determines shrinkage at 28 days under standardised conditions. An upper limit for drying shrinkage has been set for a compliant Type SL cement in AS 3972 (see **Table 1.1**). These cements may be cement-only or blended cements.

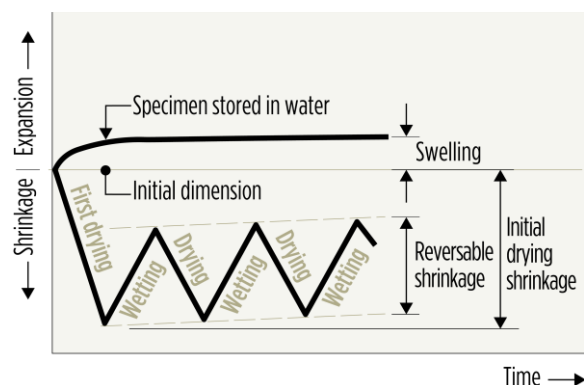

Figure 1.6 – Schematic Representation of Volume Changes in Cement Paste due to Alternate Cycles of Drying and Wetting

Relationship Between ‘Cement’ Shrinkage and Shrinkage of Concrete

The drying shrinkage values for a cement (mortar) cannot be applied directly to the shrinkage of concrete since the latter is greatly influenced by significant factors other than just cement properties. These factors include (a) the concrete components, and (b) the ambient conditions – temperature and humidity. Aggregates restrain the drying shrinkage of the cement paste. The restraining effect of the aggregate, illustrated in **Figure 1.7**, is determined by (a) the volume fraction of aggregate in the concrete, (b) its modulus of elasticity, (c) its absorption characteristics and (d) the maximum aggregate size. Aggregates that lack volumetric stability (such as certain volcanic breccias) will cause significantly higher drying shrinkage than those that are stable. The water content of the concrete influences its shrinkage – the higher the water content, the higher the shrinkage.

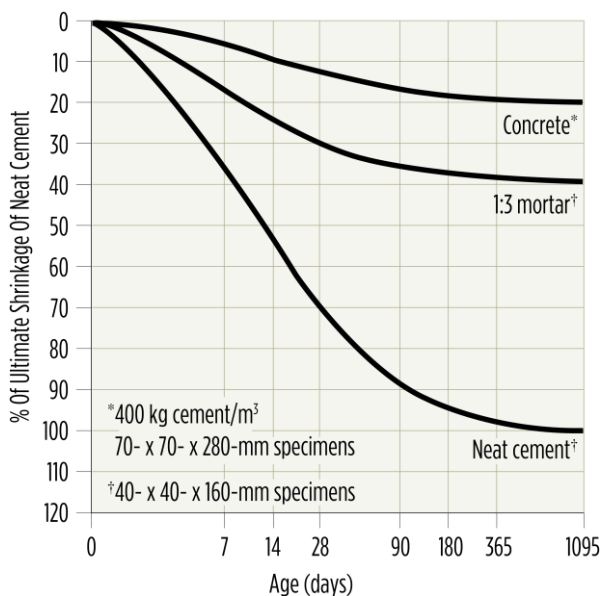

Figure 1.7 – Comparative Drying Shrinkage of Concrete, Mortar and Cement Paste at 50% Relative Humidity

Admixtures may also affect the shrinkage of concrete in a number of ways. For example, some set- accelerating admixtures (e.g. those containing triethanolamine) cause substantial increases in drying shrinkage. Also, when lignosulphonate-based water-reducing admixtures are added to a concrete mix without adjusting the mix proportions, an increase in the early drying shrinkage may occur.

The use of an admixture which enables a net reduction in the water content of the concrete will often result in reduced shrinkage. The complexity of modern admixtures is such that it is dangerous to generalise as to their likely effect.

The use of pozzolanic materials may result in either an increase or a decrease in drying shrinkage depending, in part, on their effect on the water demand of the concrete.

Therefore, using Type SL cement alone will not guarantee the production of low shrinkage concrete. The many other factors discussed need to be considered as they may outweigh the effect of the cement on the concrete drying shrinkage. This is stated clearly in the notes for Table 2 of AS 3972.

Thermal Volume Changes – The coefficient of thermal expansion of cement paste varies between 10×10^{-6} and 20×10^{-6} /°C depending, mainly, on the moisture content of the paste. The coefficient increases with increases in the relative humidity, reaching a maximum at about 70% relative humidity.

4.5 PERMEABILITY

Permeability of the cement paste depends not only on the paste porosity but also on other properties of the pore system, such as pore continuity and pore size distribution. These properties are affected by the water/cement ratio (and hence cement content) and the extent of hydration – which in turn is affected by the amount of curing given to the paste. The effect of the water/cement ratio is illustrated in **Figure 1.8** and the effect of moist curing in **Table 1.4**.

4.6 ALKALINITY

Hydrated cement paste is inherently an alkaline material having a pH of approximately 12.5. It is this high pH which allows concrete to protect steel from corrosion by assisting in the formation of a thin, passive iron oxide layer on the steel that prevents corrosion.

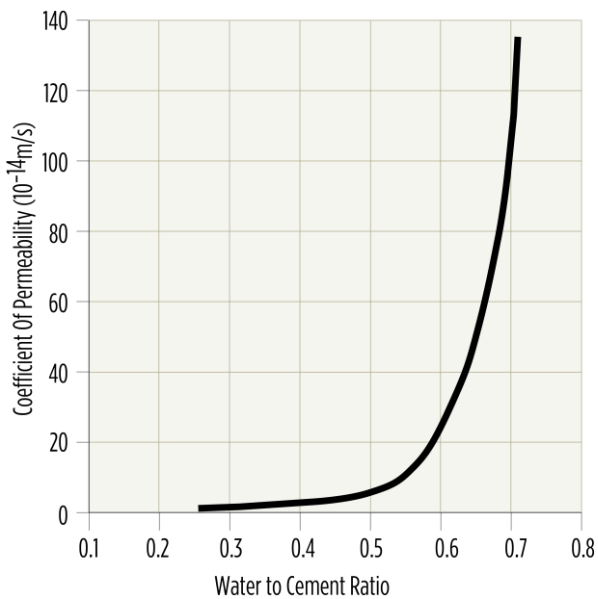

Figure 1.8 – Effect of Water/Cement Ratio on Permeability^{1,2}

The composition of cement has little or no influence on the level of alkalinity of freshly hydrated cement paste, but a reduction in alkalinity may take place as a result of the leaching of alkalis from the paste and/or the carbonation of the hydrated cement. Field and laboratory investigations have shown that the rate and extent of carbonation with blended cements tends to be higher than that with general purpose cements, but the permeability of the paste is likely to be a much more important factor in determining the risk of corrosion. Impermeable pastes carbonate only very slowly, no matter what type of cement is used.

Table 1.4 – Duration of Moist Curing Required to Achieve Capillary Discontinuity

Water/cement ratio	Duration of moist curing
0.4	3 days
0.45	7 days
0.5	14 days
0.6	6 months
0.7	1 year
>0.7	Impossible

4.7 RESISTANCE TO CHEMICAL ATTACK

General – Hardened cement paste may be attacked by aggressive chemical agents. The intensity of the attack depends on the specific properties of the agent, its concentration, and on the duration and the nature of the contact with the paste, i.e. whether it is continuous or periodic. Regardless of the nature of the aggressive agent, the chemical resistance of the paste is related to its permeability – less permeable pastes are more resistant to all forms of chemical attack.

Acids – The action of acids on the hardened cement results in the conversion of the calcium compounds in the paste to the calcium salts of the acid. The solubility of the resulting calcium salt determines to a large degree the extent of the acid attack. If the calcium salt is soluble it is readily removed by dissolution and leaching. As a result, the structure of the hardened cement is effectively destroyed. Hydrochloric acid and nitric acid give low pH solutions and calcium salts which are readily soluble. Acids which result in insoluble salts, such as oxalic and hydrofluoric acid, cause less significant damage.

Sulfates – All soluble sulfates react with hardened cement pastes causing the formulation of expansive products which, in severe cases, can result in complete disintegration of the paste, mortar or concrete.

Calcium, sodium and potassium sulfates can attack the aluminates in the cement paste. The reaction, in the presence of moisture, creates an expansive reaction product which may lead to cracking. Magnesium sulfate and ammonium sulfate are potentially more severe in their action since they attack not only the aluminates but also the silicate hydrates. Attack is progressive, and the hardened cement can be reduced to a soft mass. The severity of the sulfate attack on cement paste, mortar and concrete depends on the type of the sulfate, its concentration, whether the sulfate solution is stagnant or flowing, and temperature.

The use of sulfate-resisting cements is recommended where the risk of sulfate attack is present.

It should be noted that resistance of concrete to sulfate attack is influenced not only by the factors affecting the chemical reactions but also, and more importantly, by the factors influencing the permeability and the overall quality of the concrete – as noted in Table 2 of AS 3972. Generally, sulfate resisting concretes should be at least 40 MPa (or higher), and ideally the cementitious materials should include an SCM.

Chlorides – The major influence of chlorides in concrete is to increase the risk of corrosion of reinforcing steel. If present in sufficient concentration in the vicinity of the steel, they cause a breakdown in the passive layer which normally protects steel from corrosion in alkaline conditions. Corrosion can then occur, particularly if the alkalinity of the cement paste is simultaneously reduced by carbonation.

The use of a cement relatively high in C₃A may assist in reducing the influence of chlorides by 'binding' a portion of them. Chlorides will react with calcium aluminates to form calcium chloro-aluminates. However, this measure should not be relied upon to prevent corrosion of steel by chlorides, partly because calcium aluminates combine preferentially with sulfates (to form sulfo-aluminates) before chlorides, and partly because subsequent carbonation of the paste causes breakdown of the chloro-aluminates and the release of chloride ions into the system.

Blended cements have been shown to be advantageous. The dense pore structure which results from their use reduces the mobility of the chloride ions, extending the time to onset of corrosion.

4.8 RESISTANCE TO FREEZING AND THAWING

The freezing of ice involves an increase in the volume of the water frozen by about 9%. In saturated, or nearly saturated cement pastes, freezing of free water and the consequent volume increase will produce internal pressures which, in turn, cause dilation and cracking of the paste. Repeated cycles of freezing and thawing therefore damage cement pastes (mortars and concretes) by causing internal stresses which crack the paste and eventually cause it to

disintegrate – most particularly at the exposed surface.

The damaging effect of frost depends primarily, therefore, on the amount of free moisture within the pores of the paste, and this in turn depends on the permeability and/or porosity of the paste. Pastes of low water/cement ratio and, hence, low permeability, are inherently more resistant to frost action. The resistance of cement pastes to freezing and thawing may be improved dramatically by the purposeful entrainment of air within the concrete.

Certain types of blended cements, notably those containing fly ash with high carbon content, tend to depress the effects of air-entraining agents and to produce a less uniform and a less stable air-void system. Otherwise, the type of cement has no specific effect on the resistance of cement paste to freezing and thawing resistance.

4.9 RESISTANCE TO HIGH TEMPERATURE

The effect of high temperature on the hydrated cement paste will vary with the following factors:

- Rate of temperature rise;
- Length of exposure;
- The final temperature reached;
- Age of the hardened paste;
- Degree of saturation.

With a slow rise in temperature, the hardened paste progressively dries out, but its properties are substantially unaffected up to about 200°C. Where the rise in temperature is rapid and the concrete is saturated – for example where it has not had the time to dry out thoroughly – significant damage may occur due to moisture trapped in the pores of the concrete turning into steam and it bursting through the surface. It has also been found that the decomposition of ettringite above 100°C, in conditions where temperature rise is rapid, can lead to the creation of water vapour that may 'pool' in cooler sections of the concrete and be later released resulting in spalling.

At temperatures between 300°C and 600°C, (chemically) combined water is driven off and dehydration begins to take place, resulting in a progressive loss in strength and a material which will be severely damaged by rewetting. Exposure to temperatures above 600°C will lead to complete loss of strength and, eventually, to failure. If such conditions are expected, high-alumina cements combined with selected refractory aggregates should be used to produce a refractory concrete.

5. STORAGE, SAMPLING AND TESTING OF CEMENT

5.1 STORAGE

The principle underlying the proper storage of cement is that, as far as possible, moisture (or air which may contain moisture) should be excluded from contact with the cement. If completely protected from moisture, cement may be stored for an indefinite period of time.

Bulk cement is stored at cement plants and terminals, and at concrete batching and products plants, in steel or concrete silos. Provided moisture is excluded from the interior of such silos, cement may be stored in them for quite long periods. Satisfactory storage for several months is not unusual. Often, conveying air used to load cement into silos from tankers is not moisture free and this can lead to lump formation if the cement is not regularly used.

Cement packed in multi-layer paper sacks has a more limited storage life as moisture will be absorbed from the atmosphere and cause progressive deterioration of the cement over time. In damp weather, such deterioration may be quite rapid and will be evidenced by the development of crusting or even hard lumps in the cement. Such cement is likely to have reduced strength and extended setting times, even if the hard lumps are screened out.

Soft lumps such as those which may occur in the lower bags in a high stack from the pressure of the bags above, and which can be broken up by rolling the bag a few times, is not a sign of deterioration.

(NOTE: This soft lump formation is known as 'pack set'.)

Bagged cement storage areas must be kept dry and, as far as practical, air movement restricted. Storing bags on pallets above ground, covering stacks with tarpaulins or plastic sheeting, and ensuring that the stock is used in the order in which it is received are all measures which will assist in preventing deterioration of bagged cement.

It should be noted that Off-White cements are more prone to lump formation and can have a considerably lower shelf life than general purpose (grey) cement.

5.2 SAMPLING AND TESTING

Sampling and testing of cement for compliance with specifications is normally carried out in accordance with the requirements described in AS/NZS 2350.1 and AS 3972. The test methods for cement are described in the AS 2350 series of Australian Standards.

Testing is carried out routinely by the cement manufacturer and the results of these tests are normally available on request on a formal test certificate. Industry laboratories are generally NATA accredited to carry out the specific testing required.

6. APPENDIX – MINOR CONSTITUENTS OF CEMENT

6.1 GYPSUM

Gypsum [calcium sulfate containing two molecules of water ($\text{CaSO}_4 \cdot 2\text{H}_2\text{O}$)] is added during grinding of the clinker in order to prevent 'flash setting' of the cement when water is added. The heat from the milling operation (when using ball mills) partially converts the gypsum into 'Plaster of Paris' ($\text{CaSO}_4 \cdot 0.5\text{H}_2\text{O}$) which is a more soluble material that is able to more readily provide the sulfate ions into solution necessary to prevent 'flash setting'.

The retarding action of gypsum/sulfate is due mainly to the formation of coatings of ettringite (calcium sulfo-aluminate) on the surface of the

aluminate (C_3A) in the cement which prevents its immediate hydration. The sulfate content of cement must be controlled as excess sulfate may cause the formation of increased amounts of ettringite, leading to expansion and cracking and deterioration of the hardened cement. Consequently, cement standards specify a maximum sulfate content (expressed usually as $\%SO_3$). AS 3972 limits sulfate (as SO_3) content of cements to a maximum of 3.5%.

Gypsum/sulfate has an influence on the setting time, strength and drying shrinkage properties of cement. A cement manufacturer optimises the percentage of gypsum to ensure the best combination of these performance properties to meet the needs of the market.

6.2 FREE LIME (CaO)

The presence of free (uncombined) lime in cement may occur when the raw materials used in the manufacturing process contain more lime than can combine with the silica, alumina and iron oxides. Alternatively, free lime may occur when the amount of lime in the raw materials is not excessive, but its reaction – i.e. the cement is underburnt. When the amount of free lime exceeds certain limits, depending on the fineness of the cement, the cement shows ‘unsoundness’. The mechanism of ‘unsoundness’ is as follows: The free lime is inter-crystallised with other minerals and is therefore not readily accessible to water. It hydrates after the cement has hardened and because the hydration product occupies a larger volume than the free lime alone it may cause expansion and cracking. Thus, the hardened product is not ‘sound’.

It is evident that free lime in the cement should be limited. It is difficult, however, to specify a quantitative limit for free lime in cement because its adverse effects depend not only on the amount present but also on other factors. Consequently, cement standards generally nominate a test for ‘soundness’ to ensure that the amount of free lime present does not have an adverse effect on the hardened cement products. The relevant test is prescribed in AS 2350.5. It is the Le Chatelier Test which

involves making a cement paste, allowing it to harden and then boiling a small cylinder of the hardened paste to accelerate any latent hydration reactions and measuring any consequent expansion. An expansion limit for this test of 5 mm maximum is set in AS 3972.

6.3 MAGNESIA (MgO)

Magnesia is introduced into cement as a minor constituent of limestone. Except for a small amount held in the crystal lattice of the cement compounds, MgO normally exists in cement as the mineral periclase (MgO), a crystalline material which can exhibit long-term expansion due to later-age hydration. Most cement specifications place a limit on the amount of MgO that can be present in ‘cement’. AS 3972 limits the magnesia content in clinker to 4.5% maximum.

6.4 ALKALI OXIDES (K_2O , Na_2O)

The alkali oxides (potash and soda) are introduced into cement through the raw materials. The total content of potassium and sodium oxides in cement is small (**Table 1.2**). A reaction may occur between these alkalis and some types of aggregates which contain reactive silica. This reaction, known as ASR or AAR, creates an expansive reaction product which, if it absorbs sufficient water, may expand and cause cracking and disruption of the concrete. Although the reaction will always occur in the presence of reactive silica, damage to the concrete may be avoided when the amount of alkali in the concrete is low. While AS 3972 does not impose any limit on alkali content, many specifications set limits on the alkali content of cement expressed as Na_2O (or sodium) equivalent ($\%Na_2O+0.658\%K_2O$). The typical limit is 0.6% sodium equivalent maximum. In the presence of potentially reactive aggregate, a range of measures can be taken to minimise the risk of damage due to ASR/AAR. These are discussed in ‘*Alkali Aggregate Reaction – Guidelines on Minimising the Risk of Damage to Concrete Structures in Australia*’, Standards Australia HB-79:2015.

6.5 LOSS ON IGNITION

Loss on ignition (LOI) primarily measures the presence of moisture and carbon dioxide in the cement and is determined by heating a cement sample to 900-1,000°C. Whilst LOI can be used to indicate whether a cement has been impaired by exposure to undue levels of moisture and/or carbon dioxide, the presence of certain mineral additions such as limestone or relatively high levels of slag can affect the

result, making interpretation difficult unless the general cement composition is known.

No limit is specified in AS 3972 for LOI but the value must be reported if requested.

7. SUMMARY

Table 1.5 – Hydraulic Cements – Types and Applications

Type	Application
General Purpose (Type GP)	For general use in building and construction.
General Purpose Blended (Type GB)	For general use in building and construction. Early rates of strength gain may be lower than with Type GP, and curing may be more critical for full strength development.
High Early Strength (Type HE)	Where early strength is a critical requirement (e.g. for early stripping of formwork, precast concrete and pre-stressed concrete); In very cold weather; In repairs to concrete structures.
Low Heat (Type LH)	Where rise in concrete temperature must be limited to avoid thermal stresses (e.g. in mass concrete construction or in very hot weather); Where moderate resistance to some forms of chemical attack is required.
Shrinkage Limited (Type SL)	Where limiting the drying shrinkage of concrete is necessary for crack control (e.g. in road pavements and bridge structures).
Sulfate Resisting (Type SR)	Where high resistance to sulfate attack is required, e.g. with sulfate-bearing soils and ground waters, and in marine environments.
White and Off-White	In the production of architectural concrete and concrete products; Normally complies with the requirements of AS 3972 for Type GP or Type HE cement.
Coloured Cement	In the production of concrete products, decorative concrete paving and similar applications.
Masonry Cement	Mortar in brick, block and stone masonry construction. Unsuitable for use in structural concrete.
Oil-Well Cement	Grouting gas, oil and other deep bore holes and wells. Normally complies with the relevant specifications of the American Petroleum Institute (API).
High Alumina Cement (HAC)	Where high early strength and/or resistance to very high temperatures are required (e.g. refractory concrete and factory floors).

8. REFERENCES

- 1) AS 1316 – *Masonry cement*
- 2) AS 1379 – *The specification and supply of concrete*
- 3) AS 2350 – *Methods of testing Portland, blended cements and masonry cements*
- 4) AS 2350.1 – *Method 1: Sampling*
- 5) AS 2350.2 – *Method 2: Chemical composition*
- 6) AS 2350.4 – *Method 4: Setting time*
- 7) AS 2350.5 – *Method 5: Determination of soundness*
- 8) AS 2350.7 – *Method 7: Determination of temperature rise during hydration of Portland and blended cements*
- 9) AS 2350.11 – *Method 11: Compressive strength*
- 10) AS 2350.12 – *Method 12: Preparation of a standard mortar and moulding of specimens*
- 11) AS 3582 – *Supplementary cementitious materials*
- 12) AS 3582.1 – *Part 1: Fly ash*
- 13) AS 3582.2 – *Part 2: Slag – Ground granulated blast-furnace*
- 14) AS 3582.3 – *Part 3: Amorphous silica*
- 15) AS 3972 – *General purpose and blended cements*

9. FURTHER READING

- 1) Neville, A.M., '*Properties of Concrete*' (4th Edition), Longman Group Limited England, ISBN-0-582-23070-5 (1995), Chapters 1 and 2
- 2) Hewlett, P.C. (Editor), '*Lea's Chemistry of Cement and Concrete*' (4th Edition), Butterworth-Heinemann, ISBN-0-340-56589-6 (1998), Chapters 1-15

End Notes

- 1.1 Based on Figure 2.4 in '*Portland Cement Paste and Concrete 1*', Soroka (1979)
- 1.2 Based on Figure 6 in Journal AC 51 (November 1954)

This section discusses and describes the nature and effect of Supplementary Cementitious Materials (SCM's) when used in concrete as replacement materials for a proportion of Type GP cement. Each of the SCM's is different to the other – in terms of their sourcing and their effectiveness as cement replacement materials. The similarities and differences will be discussed.

CONTENTS

1 INTRODUCTION	2	8.7 DURABILITY OF AMORPHOUS SILICA CONCRETE	30
2 HOW SCM's WORK	3	9 THE EFFECTS OF SCM'S ON CONCRETE DURABILITY	30
3 WHY USE SCM's?	4	9.1 INTRODUCTION.....	30
4 AUSTRALIAN STANDARDS FOR SCM's	5	9.2 DURABILITY PERFORMANCE IMPROVEMENT EXAMPLES	31
5 COMPARISONS – SCM's AND TYPE GP CEMENT	5	10 SUMMARY	34
6 FLY ASH	8	11 RELEVANT AUSTRALIAN STANDARDS	35
6.1 INTRODUCTION.....	8	12 FURTHER READING	35
6.2 AS 3582.1.....	9		
6.3 FLY ASH PRODUCTION AND PROCESSING	10		
6.4 FLY ASH CHARACTERISATION	11		
6.5 FLY ASH USES	13		
6.6 DURABILITY OF FLY ASH CONCRETE.....	14		
7 GGBFS	14		
7.1 INTRODUCTION.....	14		
7.2 AS 3582.2.....	15		
7.3 GGBFS PRODUCTION AND PROCESSING	16		
7.4 GGBFS CHARACTERISATION.....	18		
7.5 GGBFS USES.....	20		
7.6 DURABILITY OF GGBFS CONCRETE	21		
8 AMORPHOUS SILICA	21		
8.1 INTRODUCTION.....	21		
8.2 AS 3582.3.....	22		
8.3 AMORPHOUS SILICA PRODUCTION AND PROCESSING	23		
8.4 AMORPHOUS SILICA CHARACTERISATION.....	24		
8.5 AMORPHOUS SILICA USES	26		
8.6 HANDLING AND STORAGE	30		

1 INTRODUCTION

Supplementary cementitious materials (SCM's) have been used in building construction for decades. In Australia the use of these materials began seriously in the 1960's and they are now firmly established as mainstream cementitious materials with coverage by the AS 3582 series of Australian Standards.

The original term used to describe these materials was 'pozzolan'. Roman masons used a volcanic ash from the Italian village of Pozzouli which, when mixed with aggregate, lime and water made a water resistant and durable mortar. These 'pozzolans' were glassy materials rich in silica and/or alumina which reacted readily with lime in the presence of water to form compounds that are virtually identical to the products found in hydrated cement.

Modern day SCM's used elsewhere in the world include naturally occurring materials, but in Australia, at this time, SCM's are sourced solely from waste materials from large manufacturing processes.

The three types of SCM's used in Australia are:

- **Fly ash** – A fine powder removed from collection devices (electrostatic precipitators or fabric filters) used to

clean the flue gases in black-coal burning power stations;

- **Ground Granulated Blast Furnace Slag (GGBFS)** – Waste material removed during the operation of blast furnaces used for the smelting of iron ore;
- **Amorphous Silica (Silica Fume)** – A very fine particulate matter collected during the production of silicon metal or ferro-silicon alloys in arc furnaces.

(NOTE: Silica fume is often provided in a densified form or as a slurry to make it easier to handle in a concrete plant.)

A naturally occurring amorphous silica product is also obtained from geothermal deposits in New Zealand.

The 'waste' products are processed after collection and converted into 'concrete grade' products.

All of the SCM's may be used in the manufacture of blended cements that meet the requirements for Type GB cements in AS 3972. Generally, silica fume is blended with Type GP cement at a maximum level of 10%, while 'slag' and fly ash may be either inter-ground with cement clinker to make Type GB cement, or the fly ash or 'slag' may be (post) blended with Type GP cement to form the Type GB product.

Blends of SCM's and Type GP cement may also be used to meet the requirements for the Type SR, SL and LH Special Purpose cements. Blended cements are generally much more effective for these 'Special' purposes than modified 'Portland' cements.

At most concrete plants, separate silos of Type GP cement and one or more SCM are present. This allows the concrete producer to provide concrete mixes with a wide range of Type GP / SCM combinations for either Normal Class or Special Class concrete applications. While the concrete produced using these on-site blends will perform in the same way as if a Type GB cement was used, the site-blended concrete mixes cannot claim to have been made using Type GB cement that conforms with AS 3972 requirements.

2 HOW SCM's WORK

The effects of all three SCM's on concrete are attributable to two primary mechanisms, namely:

- **Filler Effect** – Physical effect of void filling to produce a more-dense concrete; and
- **Chemical Reaction** – Reaction of the SCM's, in the presence of water, with lime (the by-product of the hydration of cement) to form calcium silicate hydrates (CSH) and calcium aluminate hydrates (CAH).

Fly ash and silica fume exhibit only pozzolanic activity, while GGBFS exhibits some limited hydraulic activity (reaction with water) and is activated by lime, alkalis and sulfates present in the paste. Sulfates can also act as the primary activator for GGBFS – these promoting the hydration of GGBFS resulting in a rapid gain of compressive strength. This type of cementitious material is known as a 'super-sulfated cement'.

The dependence of the pozzolanic reaction on the presence of the lime produced as a by-product of cement hydration means that the overall rate of reaction and strength gain with mixes containing SCM's lags that of mixes containing cement only. However, the ongoing reaction of the SCM's results in (generally) higher later-age strengths (after 28 days) than cement-only mixes.

The reactions and relative reaction rates of cement and cement, GGBFS and cement + fly ash are shown in **Figures 2.1 to 2.4** below.

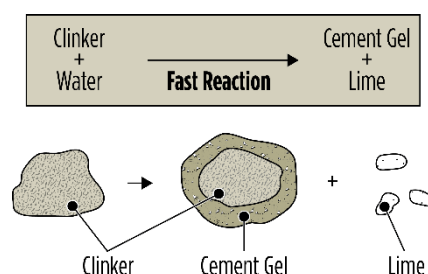

Figure 2.1 – Reaction of Portland Cement and Water

Slag has some hydraulic properties similar to Portland cement but to a very minor degree.

This reaction (**Figure 2.2**) is very slow and hence slag is not a useful cementitious material on its own. It requires an activator to speed up the pozzolanic reaction. Activators include alkalis, lime and sulfates.

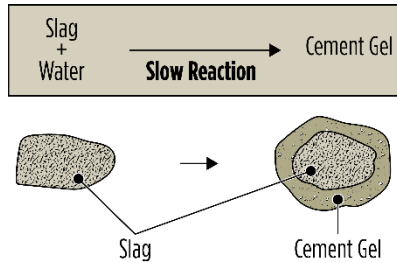

Figure 2.2 – Reaction of Slag with Water

Fly ash does not react at all with water (**Figure 2.3**).

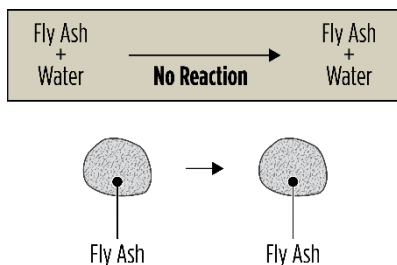

Figure 2.3 – ‘Reaction’ of Fly Ash with Water

Fly ash requires lime from the cement hydration reaction (in the presence of water) to react and form calcium silicate hydrate gel (**Figure 2.4**).

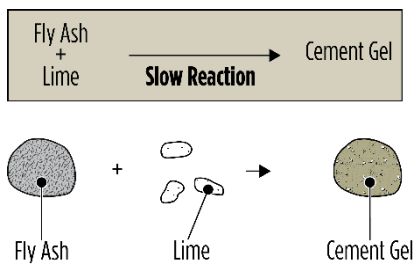

Figure 2.4 – Reaction of Fly Ash with Lime

Amorphous Silica(s) are similar to fly ash in that they rely on the lime from the hydration of cement to react with them to form cementitious products. Silica fume, due largely to its very high fineness, is the most reactive of the SCM's.

3 WHY USE SCM's?

There are environmental, technical and commercial advantages to using SCM's. Availability and product cost and performance generally dictate which SCM is used in a given situation or market area. All SCM types are not necessarily available in all regions of Australia, so 'local' availability will often dictate the SCM(s) used or specified.

Commercial Advantages

SCM's are wastes or by-products from other industries and are generally available at lower cost than General Purpose cement. The actual cost varies considerably around Australia depending on material availability and transport distance. The increasing use of imported SCM's in Australia means that source countries and exchange rates also influence pricing in any particular region.

Environmental Aspects

The SCM's are generally 'wastes' and it can be difficult for industry to find practical, economic and environmentally sensitive ways to dispose of them. Unused fly ash has been placed in waste dams or lakes. Slag tends to accumulate in large stockpiles. Silica fume disposal is problematic. There are advantages to the industries producing the 'wastes' to have the materials used profitably in concrete.

Current concerns about the CO₂ intensity of cement (and hence concrete) mean that the substitution of cement by SCM's has become a strong environmental focus. SCM's can also be used in the production of alternative binder materials with low-CO₂ intensities – binders like geopolymers and super-sulfated cements – which are gaining some credibility and utility.

Technical Considerations

SCM's generally have a positive influence on both the plastic and hardened properties of concrete. Disadvantages are minimal and any can readily be offset by other means.

As with the use of any new materials, consideration of the use of a new SCM requires that trials should be carried out to ensure that the expected and required concrete properties are achieved.

4 AUSTRALIAN STANDARDS FOR SCM's

The quality requirements for the three SCM's are described in Australian Standards (Table 2.1).

Table 2.1 – Australian Standards for SCM's

Material	Source	Australian Standard
Fly Ash	Black coal combustion facilities, usually power stations	AS 3582.1
GGBFS	Blast Furnaces for smelting of iron ore	AS 3582.2
Amorphous Silica	Naturally occurring deposits or Silica Fume – fine particulate matter collected from the refining of silicon metal / ferro-silicon alloys	AS 3582.3

5 COMPARISONS – SCM's AND TYPE GP CEMENT

Chemical Composition

The indicative chemical compositions of Type GP cement and the three SCM's types are shown below in Table 2.2.

The following broad comparisons between the four material types can be made:

- **Type GP Cement** – High in calcium and silica;
- **Fly Ash** – High in silica and alumina and low in calcium;
- **GGBFS** – High in calcium and silica with moderate alumina;
- **Amorphous silica** – High in silica, low in calcium and other elements.

Mineral Composition

The other significant contrast is in terms of the mineralogy of these materials. Type GP cement is comprised of crystalline, mineral materials (C₃S; C₂S; C₃A; C₄AF), while all three of the

SCM's gain their reactivity through being glassy (non-crystalline) materials. The glassy nature of these materials comes about through the rapid cooling of (essentially) molten materials which are produced as by-products in each of their respective industrial processes.

Particle Shapes

By virtue of their initial production and/or processing, Type GP cement and the three SCM's have different particle shapes and sizes.

Type GP cement and GGBFS are both produced by grinding an interim product (clinker and GBFS respectively) in a 'cement mill' to achieve the final cementitious product – yielding an angular, glassy looking product. Fly ash and silica fume are not usually milled (or ground) and their particle shape is more spherical reflecting the conditions (very high temperatures; molten particles transported in a gas stream) in the processes they derive from. The indicative shapes are shown in Figure 2.5 below.

Effects of SCM's on Concrete Performance

SCM's affect both the plastic and hardened properties of concrete – these effects being briefly compared in Tables 2.3 and 2.4 below. These properties will be elaborated upon in the following sub-sections of this section.

Table 2.2 – Comparison of Chemical Compositions

Component (%)	Type GP Cement	Fly Ash	GGBFS	Amorphous Silica (Silica Fume)
SiO ₂	19-26	50-70	32-35	85-95
Al ₂ O ₃	4.5-5.5	20-30	11-16	0.1-2
Fe ₂ O ₃	2-5	2-15	0.5-1.5	0.1-4
TiO ₂	-	1-2	1-2	-
Mn ₃ O ₄	-	0-0.5	0.5-1	-
CaO	62-65	0-5	32-42	0.1-0.5
MgO	1-3	0-2	7-13	0.1-1
Na ₂ O	0.2-0.7	0.2-2.5	0-0.5	0.1- 1
K ₂ O	0.5-2.5	0.2-2.5	0.5-1	0.1-1
P ₂ O ₅	0.1-0.2	0-2	-	-
SO ₃	2-3.5	0-2	1-2.5	0.1-0.5
LOI	0.5-3.5	0.1-4	0.5	1-6

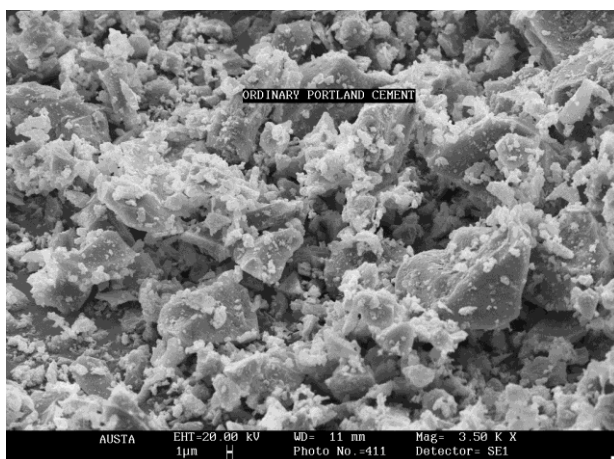

(a)

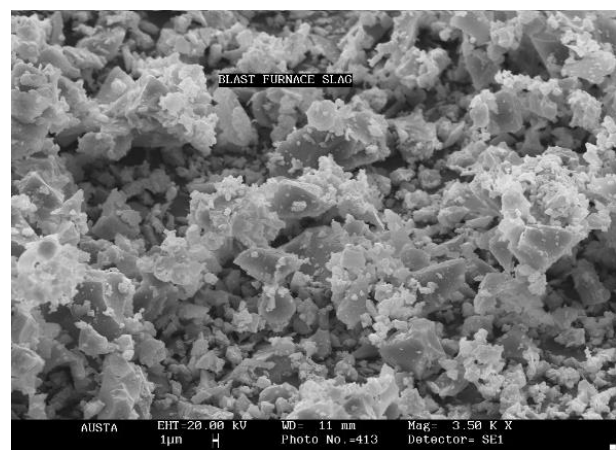

(b)

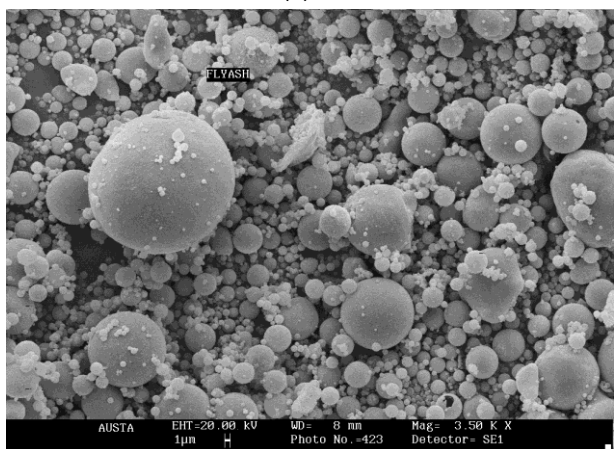

(c)

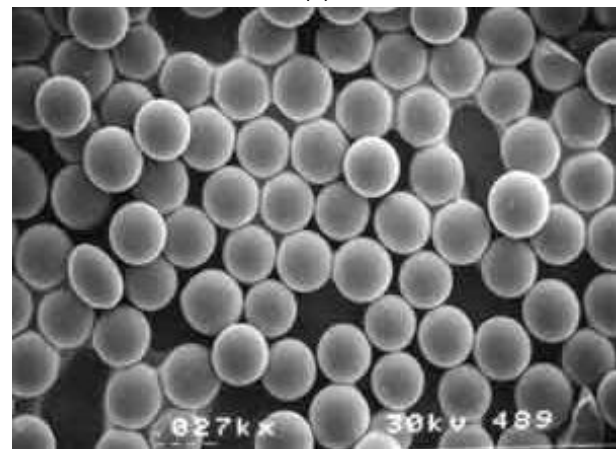

(d)

Figure 2.5 – Comparative Particle Shapes of Type GP Cement and SCM's: (a) Type GP Cement; (b) GGBFS; (c) Fly Ash; (d) Silica Fume

Table 2.3 – Comparisons of Effects on Plastic Concrete Properties

PLASTIC PROPERTIES – SCM CONCRETE VERSUS CEMENT-ONLY CONCRETE			
Property/Effect	Fly Ash	GGBFS	Silica Fume
Water Demand	Reduced	Reduced	Increased
Workability	Improved	Improved	Reduced
Segregation	Reduced	Reduced	Reduced
Cohesiveness	Improved	Same	Increased
Air Entrainment	Limitations	Same	Limitations
Pumpability	Improved	Improved	Reduced
Bleeding	Reduced	Reduced (65%)/ Improved (30%)	Greatly reduced
Finishing	Improved	Improved	Reduced
Set Times	Delayed	Delayed	Similar

Table 2.4 – Comparisons of Effects on Hardened Concrete Properties

HARDENED PROPERTIES – SCM CONCRETE VERSUS CEMENT-ONLY CONCRETE			
Property/Effect	Fly Ash	GGBFS	Amorphous Silica
Compressive Strength	Lower early, higher later	Lower early, higher later	Higher
Tensile/Flexural Strength	Slightly higher	Slightly higher	Slightly higher
Drying Shrinkage	Lower	Variable	Lower
Creep	Similar	Similar	Lower
Permeability	Much lower	Much lower	Very much lower
Sulfate Resistance	Higher (at >25-30%)	Higher (at >60%)	Higher
Chloride Resistance	Higher	Higher	Higher
Heat of Hydration	Lower	Lower	Higher/Lower
Carbonation	More at surface	Similar	Similar
AAR/ASR Resistance	Higher (at >20%)	Higher (at >50%)	Higher (at 7-10%)

6 FLY ASH

6.1 INTRODUCTION

Fly ash, a by-product or 'waste' product from the combustion of coal, has become an important material in a variety of construction industry applications. Most particularly it has been found to provide significant benefits when used as a partial cement replacement in concrete and related products, and it is this function that will be the primary subject of this

section. The fly ash in question derives from pulverised fuel-fired coal combustion where the coal is ground into a fine powder before being injected into a high temperature combustion chamber where temperatures reach about 1,800°C. The nature of the fly ash is determined in part by the nature of the coal it derives from and this in turn can determine its applicability in concrete applications. Schematic representations of a coal-fired power station and the fly ash production process are shown in **Figures 2.6** and **2.7**.

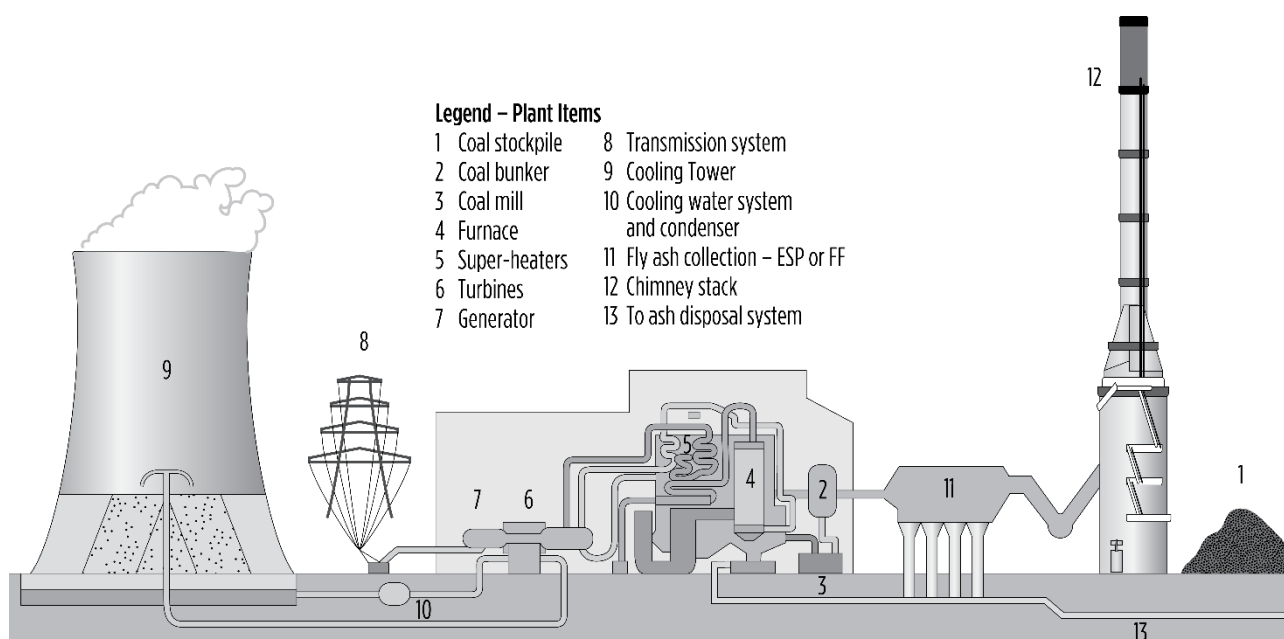

Figure 2.6 – Schematic Representation of Coal Fired Power Station

Fly ash use in concrete began in the USA in the 1930's, though its first use in Australia was not until 1949 when fly ash imported from the USA was used in grouts in the Snowy Mountains Hydro-Electric scheme in NSW. Subsequently, and certainly since the 1960's, fly ash has become a standard component in concrete mixes in regions in Australia where fly ash is available. This ready availability has been along the eastern seaboard of mainland Australia and in South Australia, though this is now changing as coal-fired power stations close.

As a material, fly ash is not unlike the volcanic ashes used by the Romans some two-thousand years ago. Their similarity derives from their chemical composition – both being rich in silica and alumina – and from their crystallinity (or lack of it), both being glassy materials.

Fly ash has as an advantage of being lower in cost than cement and hence makes concrete more cost effective. It allows a reduction in the Type GP cement content of concrete and improves concrete's environmental credentials.

Unlike Type GP cement which has a quite consistent chemical composition and mineralogy wherever it is made in the world, almost all fly ashes are chemically different. The chemistry of a given fly ash depends on the nature and proportions of the minerals (typically clays and silicate minerals) associated with the coal source. Variable mineralogy leads to variable chemistry in the fly ash which means that there is no 'typical' fly ash.

This likely variability in chemical composition for different fly ashes results in the use of their

physical characteristics as the key control parameters when producing commercial products for the concrete industry.

MANUFACTURE OF FLY ASH

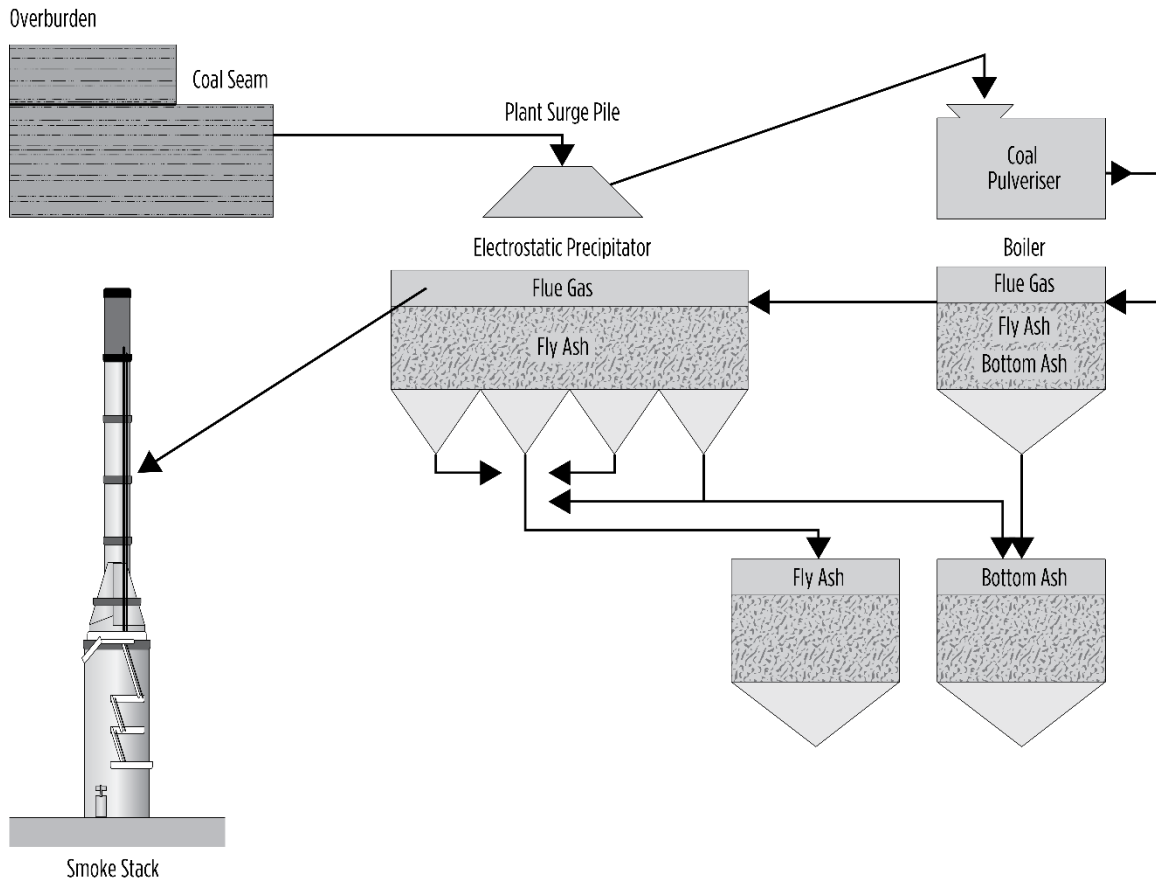

Figure 2.7 – Process for Manufacture of Fly Ash

6.2 AS 3582.1

The first Australian Standards for fly ash were published in 1971 as AS 1129 and AS 1130. The current Standard is AS 3582.1, the latest version of which was published in 2016. AS 3582.1 (2016) has the following features and inclusions:

- It defines three grades of fly ash – Grade 1 and Grade 2 for general concrete use and Special Grade, which is described as a ‘highly reactive’ material;
- It aligns with ASTM and EN requirements for the chemistry of conforming fly ashes in requiring the sum of $\text{SiO}_2 + \text{Al}_2\text{O}_3 + \text{Fe}_2\text{O}_3$ to be $\geq 70\%$ (for Australian fly ashes);
- It introduces a Strength Index minimum requirement for Grade 1 fly ash;
- It introduces a chloride ion maximum limit for all products – the value being consistent with that for cement;
- It aligns testing approaches and testing frequencies with the cement Standard; and
- It introduces the concept of Proven and Unproven Sources – with increased testing frequencies for Unproven Sources.

The key requirements for the three grades are shown in **Table 2.5**.

Table 2.5 – Specified Requirements from AS 3582.1

Property	Special Grade	Grade 1	Grade 2	Test Method
Fineness (% passing 45 µm, minimum)	85	75	55	AS 3583.1
Loss on Ignition (% maximum)	3.0	4.0	6.0	AS 3583.3
Moisture Content (% maximum)	0.5	0.5	0.5	AS 3583.2
Sulfate (as SO ₃) (% maximum)	3.0	3.0	3.0	AS 3583.8
Chloride Ion (% maximum)	0.1	0.1	0.1	AS 2350.2
Strength Index (% minimum)	100	75	-	AS 3583.6

6.3 FLY ASH PRODUCTION AND PROCESSING

Fly ash is produced when pulverised coal is burned in the combustion chambers of coal-fired power stations and derives from mineral matter present in the coal – with mineral matter comprising from 10% to 50% of the ‘coal’ that is burned. Typical mineral matter includes clays, sand and a variety of other minerals that may be found within or between coal seams. The ‘coal’ is pulverised to a fine powder in either vertical roller mills or hammer mills – with pulverised coal typically having 75% of the particles <75 µm. The pulverising frees the mineral particles from the coal particles and coal and mineral particles are exposed separately in the combustion zone. On entering the combustion zone, the temperature of the particles increases at a rate of about 2,000°C per second, and a peak temperature in the order of 1,800°C is reached. Residence time in the combustion zone is about 2-3 seconds. The coal material degasses and combusts while most mineral particles melt and are then entrained in the flue gases.

Upon leaving the combustion zone the mineral particles cool quickly and become, in the main, spherical glassy particles of fly ash. Small quantities of char – unburned coal material – are also entrained in the flue gases. The flue gases pass through particulate collection devices to clean the flue gas before the ‘clean’ gas exits the power station through the chimney.

The particulate collection devices used may be of two types – either Electrostatic Precipitators (ESP) or fabric filters (FF). ESP’s create a charge on the surface of the fly ash particles, and the charged particles are then attracted to earthed plates from which the ash is removed periodically. Fly ash removal efficiencies of 99+% are achievable. The alternative and more modern collection device are the FF which acts much like a vacuum cleaner bag. The flue gas passes through filter bags and the solid fly ash is filtered out. The fly ash is then removed periodically from the filter bags. Fly ash removal efficiencies of 99.8+% are achievable with this process.

To obtain a fly ash product suitable for use as a cementitious material in concrete, some processing of the fly ash is generally required. Initially, the fly ash needs to be assessed for its unburned carbon content (known as its LOI level = Loss on Ignition). Fly ash with suitably low levels of LOI may then also be beneficiated to produce a product of the required Fineness (where Fineness means the % passing a 45-micron sieve using wet sieving). Processing to increase Fineness levels usually involves passing the fly ash through a centrifugal separator (known as a classifier) where coarser fly ash particles are removed leaving the final, finer cementitious product. Fly ash may also be milled (in a ball mill) to increase Fineness levels. ‘Fineness’ as measured using a 45-micron sieve provides a very coarse measure of the particle size distribution of ‘concrete grade’ fly ash which typically has a median particle size in the range of 10-20 microns.

However, the Fineness measure is suitable for use as a production tool.

Routine testing used to control production usually involves testing for moisture content, Fineness and LOI. In situations where high LOI levels are encountered or where problematic LOI material is found, a 'Foam Index test' may also be used for additional screening.

Fly ash processing primarily involves (a) controlling the Fineness of the fly ash product (the actual Fineness level and its consistency) and (b) ensuring that LOI levels meet Standards requirements. This processing does not alter the fly ash chemistry or otherwise alter the inherent reactivity of the fly ash.

6.4 FLY ASH CHARACTERISATION

Bearing in mind that the major use of fly ash as a cementitious material is as a partial cement replacement in Normal Class concrete mixes, fly ash characterisation, at its simplest level, involves ensuring that (a) Standards requirements are met and (b) the product is of consistent quality – which in a practical sense means managing Fineness and LOI levels. Most other fly ash properties are intrinsic and are not able to be easily modified. However, knowledge of other fly ash chemical components and how effective the fly ash is likely to be as a cement replacement are key requirements for understanding the likely performance of fly ashes intended for commercial use.

Physical Characterisation

Understanding physical fly ash properties is important if it is to be produced and used optimally.

Fineness – The Fineness is determined, in accordance with AS 3583.1, by wet sieving through a 45-micron sieve. In the Australian Standard the Fineness represents the weight % of fly ash **passing** through the sieve. (In other Standards the weight % **retained** on the sieve is used.) Fineness provides a coarse measure of fly ash particle sizing. It is of value as a control measure for fly ash processing in terms of (a) ensuring the Fineness value meets the requirement of the Standard, and (b) as a

measure of the consistency of the product. For any high performance/high reactivity fly ash (e.g. Special Grade), where the improved performance is obtained primarily by increasing the Fineness, the test at 45 microns serves little purpose as generally, 100% of the product would pass 45 microns. A more accurate estimate of likely reactivity for a fly ash is obtained from a full particle size distribution (PSD) using, for example, a laser diffractometer device. Typically, the mass median diameter (MMD) for a Grade 1 fly ash would be in the range 10-20 microns, while a high performance/high reactivity fly ash would have an MMD of about 3-4 microns. Increasing the Fineness of a given Fly ash results in a decrease in the Relative Water Requirement and an increase in the Strength Index value. To produce a fly ash conforming with the Special Grade requirements of AS 3582.1 it is usually necessary to increase the Fineness of the ash – either by additional centrifugal separation (i.e. classifying) or by milling the ash.

Relative Density – The Relative Density (RD), determined using AS 3583.5, is dependent on (a) the chemical composition of the fly ash, (b) the proportion of hollow fly ash particles or particles containing voids, and (c) the Fineness. The typical range of Relative Density for fly ashes is 2.0-2.5. For a given fly ash at a particular Fineness value the RD is generally quite consistent. As Fineness increases, so too does the RD – in part through removal of coarser particles that are more likely to contain voids. The RD value is used in concrete mix design to convert the weight of fly ash added into volume.

Relative Water Requirement and Strength Index – Relative Water Requirement (RWR) and Strength Index (SI) determinations are carried out using a mortar mix containing cement and fly ash, a standard sand and water and according to the methods described in AS 3583.6. The Relative Water Requirement and Strength Index values of the cement+fly ash mortar are determined relative to a cement-only mortar. The fly ash replacement level used is about 25%. The RWR is improved where the fly ash has a finer PSD and where the particles are more spherical. The same properties also improve the Strength

performance of the fly ash mortar. The RWR and SI values cannot be used to determine the likely efficiency of a fly ash when used in concrete, though a performance trend can be assumed. (**NOTE:** It is *incorrect* to believe that a fly ash with a SI of 90% would provide 90% of the strength performance of the test cement used. Because the proportion of fly ash in the cement/fly ash mix is only 25%, a 90% SI means that the fly ash has only 60% of the strength performance of the cement – as determined by this particular test.)

Microscopy – Microscopy generally, and scanning electron microscopy (SEM) in particular, are useful in assessing the shape of fly ash particles and the proportion of other components like hollow fly ash particles (called cenospheres) and hollow fly ash particles containing smaller particles (called perlospheres).

Mineral and Chemical Characterisation

As previously mentioned, fly ash forms when the fine mineral particles present in pulverised coal (mostly) melt at the high temperatures in the combustion zone and then quite rapidly cool. As a result of the rapid cooling a high proportion of fly ash is glassy material – that is, it has no crystalline structure. A few minerals, in low proportions, may be found in fly ash. The two predominant minerals are quartz (SiO_2) and mullite ($3\text{Al}_2\text{O}_3 \cdot 2\text{SiO}_2$). Magnetite (Fe_3O_4) may also be present where iron-based minerals (e.g. siderite) are part of the coal mineral assemblage. The ‘glass’ content of fly ashes is typically about 60%. The presence of quartz in the fine fly ash presents OH&S concerns as noted in the Handling and Storage sub-section to follow.

Key chemical parameters used to characterise fly ash are those that potentially impact end-use performance. These include the overall chemical composition and some critical individual components, as discussed below.

Chemical Composition (General) – Determined using AS 2350.2, the overall chemical composition, and particularly the combined proportions of silica, alumina and iron provide a primary performance criterion that is necessary to meet AS 3582.1 requirements. This criterion is also used in the ASTM and EN Standards, where the proportion of ($\text{SiO}_2 + \text{Al}_2\text{O}_3 + \text{Fe}_2\text{O}_3$) must exceed 70% for siliceous

fly ashes and 50% for calcareous fly ashes. Having sufficiently high levels of silica and alumina-based materials is important to ensure that a pozzolanic reaction will occur so that the products of the pozzolanic reaction (calcium silicate hydrates and calcium aluminate hydrates) are in sufficient quantity to contribute to concrete strength and durability performance.

Sulfate – Determined using either AS 3583.8 or AS 2350.2, the sulfate content is important when using fly ash in concrete as excess sulfates may contribute to expansive reactions in concrete and these may result in concrete cracking. In siliceous fly ashes particularly, sulfate levels are usually quite low (<0.5%).

Alkalis – Determined using AS 2350.2 the alkali content of fly ash is of importance most particularly when the total alkali content, expressed as % Na_2O Equivalent, exceeds 5%. (Total alkalis, as % Na_2O Equivalent = % Na_2O + 0.658% K_2O .) The importance of the alkalis will be discussed in the ‘Uses’ sub-section following.

Chloride – Determined using either AS 3583.13 or AS 2350.2, the chloride ion content is useful in helping determine the overall amount of chlorides in a concrete mix, which includes the chloride ion content of cement, admixtures and aggregate materials. Chloride ions may migrate through the concrete over time and, if and when they reach any embedded reinforcing steel, may initiate and/or accelerate corrosion of the steel.

Moisture Content – Determined using AS 3583.2, this test measures the amount of moisture adsorbed on the surface of the fly ash particles. The moisture content, if too high, may affect the free-flowing nature of fly ash and in more severe circumstances may result in the formation of lumps which will affect the flow of fly ash through a silo.

Loss on Ignition (LOI) – Determined using AS 3583.3, the LOI test measures the amount of unburned char remaining in the fly ash. High levels of LOI may (a) create dark (and variable) colouration of the ash, (b) appear on the surface of concrete – on the bleed water or on the finished surface, and (c) adsorb air entraining

agent added to concrete and limit the ability to entrain air which may be required for slip-formed concrete or to manage Freeze-Thaw durability issues.

Magnesium Oxide (MgO) – Determined using AS 2350.2, the determination of MgO content is meant to ensure that the mineral periclase (MgO) is not present in detrimental amounts. If present, periclase may cause expansive reactions in hardened concrete leading to cracking. While periclase may be present in fly ashes derived from brown coals it is not likely to be present in black coal ashes. The limit for MgO has been removed from AS 3582.1 but persists in some international fly ash Standards, primarily because these Standards include coverage of brown coal fly ashes.

6.5 FLY ASH USES

In Australia, fly ash has been a standard cementitious additive in concrete since the mid-1960's, almost always as a partial cement replacement. Australia's historic dependence on coal-fired electricity meant that in most States, fly ash was readily available. The use of high-quality coals in modern power stations meant that fly ash quality was generally high and consistent and consequently fly ash became the most common SCM in use in Australia. Previously, the only mainland State where fly ash was not available locally was Victoria. The ready uptake of fly ash was due to it (a) being of lower cost than cement, (b) having a similar cementitious efficiency to cement (at 20-25% replacement rates) and (c) improving concrete durability, particularly in relation to mitigation of Alkali Silicate Reaction (ASR) which had been demonstrated by Australian research. Using fly ash to limit the risk of ASR was effectively mandated by some authorities (e.g. in Queensland) which meant nearly all concrete plants in those regions had a silo of fly ash.

While fly ash is used to improve concrete durability performance, its general use is driven by economic factors. Its lower cost and the improvement in concrete plastic properties, particularly increased cohesiveness that improves the 'pumpability' of fly ash mixes, are

the major drivers for fly ash in 20-32 MPa concrete for general applications.

Fly ash use as a cementitious material is effective because of its pozzolanic behaviour.

Fly ash considerably improves the workability and pumpability of plastic concrete. This is often attributed to the 'ball bearing effect' – this being a consequence of the sphericity of the fly ash particles. It is more likely however, to be due to the increased paste content in fly ash mixes – a result of the difference in density between fly ash and Type GP cement. If 100 kg of Type GP cement (SG = 3.15) is substituted with 100 kg of fly ash (SG of 2.1), there is an increase in paste volume of about 15 Litres/cubic metre.

Typical Fly Ash Use in Concrete

For the 'typical' 20-32 MPa concrete mix, fly ash is used as cement replacement at a level of 20-30%. This may be adjusted seasonally, particularly in the southern-Australian States, where replacement levels may be lower in winter. In North Queensland, replacement is typically at 30% all year around. At these replacement levels, lower early-age strengths (3-days and 7-days) can be expected relative to cement-only mixes, and depending on the fly ash being used, a slightly higher cementitious content may also be required to achieve 28-day strengths equivalent to cement-only mixes.

It is not uncommon now, with the wider availability of ground granulated blast furnace slag (GGBFS), for ternary mixes to be used in Normal Class concretes – again most often for improved economy. Usually, the cement content is kept at about 50% and two SCM's make up the remainder of the cementitious content – typically with fly ash at 20% and GGBFS at 30%. The increased proportion of SCM's in these ternary mixes also means lower early-age strengths. The high reactivity of the GGBFS component usually provides good 28-day strength performance.

Relative to cement-only mixes, binary or ternary concrete mixes show elongated setting times (typically 30-45 minutes at 'normal' ambient temperatures, and potentially longer at temperatures <10°C), good workability and pumpability, lower bleed and are typically

easier to finish. The combination of lower bleed rates, slightly longer setting times and lower early-age strengths can mean an increased risk of plastic shrinkage cracking, though experienced concrete placers are readily able to cope with this potential issue.

High Volume Fly Ash (HVFA) Concrete (usually with cement replacement levels of at least 40%) – HVFA is used in some applications, most typically in mass concrete where lower concrete temperatures are required. HVFA concrete has also been proposed for general concrete applications though uptake has been low. With HVFA concrete, the plastic concrete can be quite ‘sticky’, and early-age and 28-day strengths are affected by the high fly ash content. A somewhat higher cementitious content (at least 40 kg/cubic metre more) is required to be able to achieve the same 28-day strengths as a mix with a 25% fly ash replacement level. Alternatively, a much lower water/binder (W/B) ratio can be used to improve strength performance. Australian research (*‘Guidelines for the use of High-Volume Fly Ash Concretes’*, CSIRO, 1995) has developed mix designs and carried out a comprehensive testing program involving HVFA concrete. While recognising some of its limitations the study shows that HVFA concrete gives excellent durability performance. The research work also notes several prominent uses of HVFA concrete in a range of construction projects.

6.6 DURABILITY OF FLY ASH CONCRETE

The use of fly ash as a partial cement replacement material in concrete results in significantly improved durability performance of the concrete – relative to cement-only concrete. The reasons for the improved performance and the actual effects are quite similar for each of the SCM’s. Rather than describe the durability-related performance for each SCM separately, a sub-section is dedicated to durability performance (sub-section 9).

7 GGBFS

7.1 INTRODUCTION

In the Australian concrete industry context, the term ‘slag’ generally refers to ground, granulated, (iron) blast furnace slag – with the descriptors to be explained and developed in this section.

(NOTE: In a general sense, the term ‘slag’ refers to a waste material separated from metals during the smelting or refining of an ore in a blast furnace. ‘Slags’ are formed during the smelting or refining of many ore types, and consequently there are (for example) copper slags, lead slags, and of particular interest to the Australian concrete industry, iron slags.)

To be of value as a cementitious material, (iron) blast furnace slag needs to be appropriately processed to create a product with the necessary performance and consistency. Specifically, the (iron) slag must first be quenched to form slag granulate (GBFS) – a glassy mineral product – and then the granulate is milled to cement-like fineness in a ‘cement’ mill – creating Ground Granulated Blast Furnace Slag (GGBFS).

GGBFS has a long history of use as a cementitious material in many countries, but in Australia its use began in about 1966 as a cement replacement in concrete used in the expansion of the steel works at Port Kembla. This use continued over the next 20 years with the placement of over 1 million cubic metres of concrete at that location. The initial use of GGBFS in the Port Kembla, Sydney and Newcastle areas was often as a separate cementitious material, though subsequent price increases saw it fall out of favour. In NSW in particular, the use of slag then developed as a component of blended cements from about 1969 – as a 30% GGBFS blend for general concrete use and as a 65% GGBFS blend for Low Heat and Marine Concrete uses. Where slag was readily available it was also being used in ternary mixes with cement and fly ash – these mixes then known as ‘triplex’ mixes. Typically, these ‘triplex’ mixes comprised 40% Portland cement/ 40% GGBFS/ 20% fly ash. In addition to Port Kembla, slag was also produced and used in the regions surrounding the steel works in Newcastle (NSW) and

Kwinana (WA). Today only the Port Kembla steel works remains in operation. This has not limited the use of slag however, with slag granulate being imported from Japan into most Australian States.

While GGBFS use as a cement replacement was quite well understood through the initial experiences, its role in enhancing the durability characteristics of concrete became more prominent as a result of the use of a blended cement containing 60% GGBFS/ 40% ACSE (Shrinkage Limited) cement in the manufacture of concrete immersed tube units for the Sydney Harbour Tunnel which was constructed in about 1990. Concrete made with the slag blend cement met the demanding requirements for this project – these included high compressive strength, high durability, low heat, able to be easily placed and able to be made with a high degree of consistency.

In addition to its being an effective cementitious material, GGBFS improves the environmental credentials of concrete through its use as an efficient cement replacement – lowering the embodied CO₂ and embodied energy levels attributable to concrete. GGBFS does this in a more effective way than other Supplementary Cementitious Materials (SCM's) through being able to be used at higher replacement levels – typically up to 65%. This contrasts with the usual replacement levels for fly ash and silica fume of about 30% and 10% respectively.

7.2 AS 3582.2

Slags derive from processes that are well managed and highly controlled. While the chemistry of slags may vary from blast furnace to blast furnace, from any single source they are generally quite consistent. The chemistry of slag is determined by (a) minerals associated with the iron ore, and (b) the limestone added to the melt to control the melting point of the slag. The chemistry of slag is consequently

dominated by calcium from the limestone and silica from the ore minerals. Critical to GGBFS performance is the proportion of glass content, this being a result of the 'granulation' process – the rapid cooling of the molten slag that forms the slag granulate precursor to GGBFS. The glass content is a significant contributor to GGBFS reactivity and is a function of the efficiency of the granulation process.

The first Australian Standard for GGBFS was published in 1991. The current version is AS 3582.2 (2016).

AS 3582.2 nominates 14 important compositional and performance properties but only provides limits for four of them. These four limits are for key chemical components. The Standard does not set any limits for physical (e.g. Fineness) or performance (e.g. Relative water requirement or Strength Index) characteristics. The nominated suite of compositional and performance properties is shown in **Table 2.6**.

While the Standard does not require that the product be tested in concrete to ensure that it is suitable, it does differentiate between 'Proven' and 'Unproven' slag sources. 'Unproven' sources need to be tested at a higher frequency (for a period of six months) until there is confidence in the quality and consistency of the material. While not all nominated properties have limits defined in the Standard, purchasers may request test data for any or all nominated properties.

Like the fly ash Standard, AS 3582.2 uses the % passing a 45-micron sieve as a measure of Fineness and as an indicator of relative reactivity for a given slag source. While Blaine surface area measurement (as used for cement) can be carried out on GGBFS, it does not provide as good an indication of likely reactivity/performance as the Fineness measured using the 45-micron sieve.

Table 2.6 – Properties Nominated in AS 3582.2 (2016)

Property	Limit	Reference Test Method
Fineness, by mass, % passing 45-micron sieve	-	AS 3583.1 or AS 2350.9
Insoluble Residue (%)	-	AS 3583.14
Loss on Ignition (%)	-	AS 3583.3
Sulfate, as SO ₃ (%)	-	AS 3583.8 or AS 2350.2
Sulfide Sulfur, as S (% maximum)	1.5%	AS 3583.7
Magnesia (MgO) (% maximum)	15.0%	AS 3583.9 or AS 2350.2
Alumina (Al ₂ O ₃) (% maximum)	18.0%	AS 3583.10 or AS 2350.2
Total Iron (FeO) (%)	-	AS 3583.10 or AS 2350.2
Manganese (MnO) (%)	-	AS 3583.11 or AS 2350.2
Chloride Ion Content (% maximum)	0.1%	AS 3583.13 or AS 2350.2
Total Alkali (%)	See note	AS 2350.2
Relative Density	-	AS 3583.5
Relative Water Requirement (%)	-	AS 3583.6
Strength Index (%)	-	AS 3583.6

NOTE: If alkali aggregate reaction is considered likely, the Available Alkali test to AS 3583.12 may be required. See HB 79 for further information.

7.3 GGBFS PRODUCTION AND PROCESSING

Iron blast furnace slag is a by-product of the iron-making process – a process that involves the production of iron metal from iron ore. Iron ore, fluxing agents (typically limestone or dolomite), fuels (typically coal or natural gas) and oxygen are fed into a blast furnace where the mixture is heated until the ore and flux are molten. The mineral materials associated with the iron ore combine with the fluxing agents allowing the molten materials (iron and ‘slag’) of very different densities to be separately ‘tapped off’ from the blast furnace and subsequently separately processed. The process is shown diagrammatically in **Figure 2.8**, and the molten iron and slag materials in **Figure 2.9**.

The slag that has been ‘tapped off’ can be treated in either of two ways – it can be air cooled or it can be quenched. Quenching involves the rapid cooling of the slag using (typically) water sprays. This rapid cooling

BLAST FURNACE

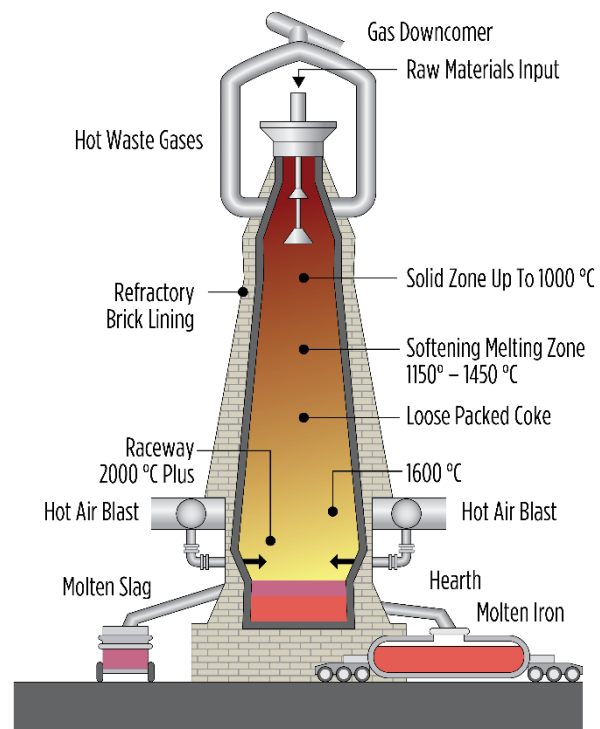

Figure 2.8 – Blast Furnace Process

results in the formation of a glassy product known as slag granulate (GBFS) which has a sand-like consistency – typically 1-3 mm in size, with a maximum particle size of about 8 mm. This material contrasts with the air-cooled slag which is a more massive material and which, after crushing and screening using conventional quarry processes, is commonly used as an aggregate material in road-making and in a variety of other end uses (see **Figures 2.10 (a) and (b)**).

Slag granulate contains a high proportion of glassy material (often >90%) with a chemical composition like that shown in **Table 2.7**.



Figure 2.9 – Molten Iron and Slag

Table 2.7 – Typical Slag Granulate Composition

Component	Proportion (%)
CaO	40
SiO ₂	35
Al ₂ O ₃	15
MgO	5
Total Alkali (as Na ₂ O Equivalent)	0.5
Fe ₂ O ₃	0.5

Slag granulate is a relatively fine and partly reactive material that can be stored in exposed stockpiles for some time before milling to form GGBFS. In some ambient conditions, particularly with higher temperatures and moisture levels, slag granulate can undergo 'weathering' that reduces the cementitious efficiency of the final GGBFS product. Weathered granulate shows higher moisture and Loss on Ignition (LOI) levels than fresh

product and the performance of the GGBFS product, as indicated by strength testing of mortar or concrete samples using the product, is reduced.



(a)



(b)

Figure 2.10 – (a) GBFS and (b) Slag Aggregate

Milling Slag Granulate

Slag granulate is milled to form GGBFS in 'cement' mills – either ball mills or Vertical Roller Mills (VRM's) – and this milling can be carried out by alternating manufacturing runs of cement and GGBFS if required. Granulate may be milled alone to form GGBFS or by inter-grinding with cement clinker to form Slag Cements.

(NOTE: Slag (Type GB) cements may also be manufactured by (post) blending Type GP cement and GGBFS.)

Granulate is harder to grind than cement clinker, and when inter-grinding clinker and granulate the cement may dominate the finer fractions of the resultant Slag Cement due to the relative grindabilities of the two components. Grinding agents are invariably used to improve milling efficiencies and to

provide a free-flowing cementitious product – for both GGBFS and Slag cement.

Some manufacturers add gypsum when milling slag granulate – at levels of up to about 5% gypsum, but typically at 2-3% gypsum.

(NOTE: Gypsum is always used when manufacturing inter-ground Slag Cements.)

There is some conjecture about the value of using gypsum in GGBFS manufacture as it (a) requires an additional material in the process, and (b) requires another property (SO₃ content) to be monitored and tested. There is some theoretical and empirical evidence that milling granulate and gypsum, with resultant SO₃ levels in the GGBFS of up to 3.0%, can improve concrete performance by way of (a) improved early-age strength development, (b) lower levels of concrete drying shrinkage, and (c) improved durability performance, particularly resistance to sulfate attack.

The 'Fineness' of the GGBFS product can be measured in two ways – using air permeability, with the result expressed as a surface area value with the unit m²/kg; or as the %-retained on (or passing) a 45-micron sieve. In Australia, GGBFS surface area levels are usually at least 450 m²/kg, while the proportion retained or passing a 45-micron sieve is dependent on the effectiveness of the separator on the mill – with typical values of '%-retained' in the range 1-5%. For a given GGBFS product, the proportion of product retained on or passing the 45-micron sieve provides a higher correlation with Strength Index performance results than does the surface area measurement using air permeability.

7.4 GGBFS CHARACTERISATION

Like any material used in concrete manufacture, GGBFS must meet the requirements of the Australian Standard and any relevant specification and should be of consistent quality. As a cementitious material, and particularly when used in high proportions, GGBFS is an important determinant of concrete compressive strength consistency. Where granulate is imported this creates a risk of potential variability that must be understood

and addressed (tested for) when manufacturing GGBFS.

Physical Characterisation

Fineness – The Fineness is determined, according to either AS 3583.1 or AS 2350.9, by sieving through a 45-micron sieve, and determining the percentage of the sample, by mass, that passes through the sieve. This provides a coarse measure of the particle size distribution but is adequate to manage the consistency of the product during manufacture. Alternatively, the air permeability method used for cement (AS 2350.8) can be used and Fineness Index /surface area expressed as m²/kg determined. In practice, variability in strength performance of GGBFS appears to be more closely related to the Fineness determined by sieving than that expressed as a surface area.

Relative Density – The Relative Density (RD) of GGBFS is determined using AS 3583.5, and typically has a value of about 2.9 and is generally quite consistent for a given granulate source. The RD value is used in concrete mix design to convert the weight of GGBFS added into volume.

Relative Water Requirement and Strength Index

– Relative Water Requirement (RWR) and Strength Index (SI) determinations are carried out using a mortar mix containing cement and GGBFS, a standard sand and water and according to the methods described in AS 3583.6. The Relative Water Requirement and Strength values of the cement + GGBFS mortar are determined relative to the water requirement and strength obtained with a cement-only mortar. The slag replacement level used in the tests is about 50%. The RWR is improved where the GGBFS has a higher Fineness, as is the Strength Index. The RWR and SI values cannot be used to determine the likely efficiency of GGBFS when used in concrete, though a performance trend can be assumed.

Microscopy – Whether using a light microscope or Scanning Electron Microscopy (SEM) there is little value that can be obtained by observing the GGBFS product. It is instructive that the appearance of GGBFS and Portland cement particles are very similar –

both being fractured 'glassy' particles ranging from coarse to relatively fine – though this is not surprising since both are produced by crushing larger particles in a mechanical comminution (see image **Figure 2.5**).

Mineral and Chemical Characterisation

As previously noted, GGBFS is a reactive cementitious material because of its high glass content, this being a consequence of the rapid cooling/quenching that occurs during the granulation process, forming what has been described as 'supercooled liquid silicates'. Comparing blast furnace slags from various sources it is apparent that the calcium and silica contents are quite consistent (about 40% as CaO and 33-37% as SiO₂ respectively), but that there are quite variable alumina and magnesia contents (8-18% as Al₂O₃ and 5-14% as MgO respectively). Iron, manganese and sulfur contents are reasonably variable, but these components are found at much lower levels, each typically at 0.5-2%. In general terms, GGBFS is described as being comprised of glass silicates and alumino-silicates of calcium and magnesium plus compounds of iron, sulfur, manganese and other minor and trace elements. GGBFS chemistry and its importance will be discussed in greater detail below.

Generally, national Standards do not nominate a minimum glass content for GGBFS for cementitious use – they usually rely on performance requirements rather than prescribing properties like minimum glass content. GGBFS products used commercially would be expected to have a glass content (determined microscopically or by X-Ray Diffraction) of >90%.

Chemical Composition (General)

Determined using AS 2350.2, this testing measures the proportions of the major and minor elements, expressed as the relevant oxide, and allows chemical moduli such as those described in international Standards like EN 15167-1, to be determined. The chemistry of slag from a single source is generally quite consistent as the iron making process is carried out with a high degree of chemical control. There may, however, be some variation in chemistry between slag sources because of raw material variations.

Sulfide Sulfur – Determined using AS 3583.7 and expressed as %S. The AS 3582.2 limit of 1.5% controls the proportion of this reduced sulfur species that can potentially have some detrimental effects in concrete in its original form, or when ultimately oxidised to sulfate. Testing of concrete has shown that sulfides have oxidised and are no longer present after about one year – generally without causing any expansion or instability.

Sulfate Sulfur – Determined using AS 3583.8 or AS 2350.2 and expressed as %SO₃. Sulfates derive directly from the slag or by oxidation of slag sulfides, or from the intended addition of gypsum during GGBFS milling. Maximum allowable levels of sulfate are set in all cementitious materials because of concerns about the formation of expansive reaction products in concrete – this leading to an increased risk of concrete cracking.

Magnesium Oxide – Determined using AS 3583.9 or AS 2350.2 and expressed as %MgO. The AS 3582.2 limit of 15.0% provides some confidence that the mineral periclase will not be present. Periclase can react to form expansive products, and if present in sufficient proportion, can cause concrete cracking.

Alumina – Determined using AS 3583.10 or AS 2350.2 and expressed as %Al₂O₃. Despite the increased resistance of concrete to sulfate attack when using (for example) 65% slag cement, there is evidence that slags with higher alumina contents (about 18%) may have less resistance to sulfate attack than slags with lower alumina contents (about 11%). Limiting the alumina content to a maximum of 18.0% (AS 3582.2) helps ensure that slag concrete provides good durability performance.

Iron Oxide – Determined using AS 3583.10 or AS 2350.2 and expressed as %FeO. This measure reflects, in part, the effectiveness of the separation of the slag from the molten metal. Typical levels are 0.5-2.0%.

Manganese Oxide – Determined using AS 3583.11 or AS 2350.2 and expressed as %MnO. Manganese is a mineral associated with iron. The levels of MnO in GGBFS are typically 0.5-1.0%.

Chloride – Determined using AS 3583.13 or AS 2350.2 and expressed as %Cl – the chloride ion content is useful in helping determine the overall amount of chloride in a concrete mix, along with the chloride ion content of cement, admixture and aggregate materials. Chloride ions may migrate through the concrete over time and, if and when they reach any embedded reinforcing steel, may initiate and/or accelerate corrosion of the steel.

Total Alkalis – Determined using AS 2350.2 and expressed as %Na₂O Equivalent (%Na₂O + 0.658%K₂O). The alkali content of GGBFS is of importance most particularly if the GGBFS is to be used in any concrete mix using potentially reactive aggregates. AS 3582.2 requires that reference be made to the HB 79 document if any risk of alkali aggregate reaction exists. The importance of the alkalis will be further discussed in the 'Uses' sub-section below.

Loss on Ignition (LOI) – Determined using AS 3583.3, the LOI test measures the amount of combustible material in the GGBFS. The test result should be corrected to account for any oxygen uptake by the sample during testing due to the oxidation of reduced sulfur or iron species.

7.5 GGBFS USES

While early GGBFS use in Australia was confined to regions where steel mills were operating – around Port Kembla and Newcastle in NSW from the mid-1960's, and around Kwinana in WA from the early 1970's – it has now become the most widely-used SCM in Australia. While the availability of 'local' slag granulate (GBFS) is now confined to the Port Kembla (NSW) region, slag granulate is being imported into all mainland Australian States, with GGBFS being produced locally for supply in those regions. Little if any GGBFS is imported.

In part, the growing volumes of GGBFS use are attributable to (a) the ready acceptance of SCM's as fundamental cementitious materials in this country, and (b) the decline in fly ash availability in many areas. Slag is a particularly versatile SCM and is able to be used as a low-

level cement replacement (nominal 30%) in Normal Class concrete and also as a high-level cement replacement (nominal 65-70%) for special end uses. While early-age concrete strengths with slag use (at all proportions) are lower than those obtained with 100% cement mixes, later age strengths are equivalent to, or better than, 100% cement mixes. There are several added advantages to using GGBFS including (a) lower cost, (b) lower concrete embodied CO₂ and embodied energy levels and (c) improved durability performance. One of the first uses of GGBFS was in ternary blends with cement and fly ash, and this is not an uncommon approach today.

Use of GGBFS as a cementitious material in Australia has grown to almost 2 Mt in 2016, with about 60% of this being imported material.

GGBFS use as a cementitious material is effective primarily because of its activation by lime, alkalis and sulfates in the cementitious paste. Unlike fly ash, GGBFS does have some slight reactivity with water alone – a property known as latent hydraulic behaviour.

In a concrete paste, lime is formed as a product of cement hydration and this lime is available to react with SCM's used as partial cement replacements. GGBFS hydration is also activated by alkalis and sulfates dissolved from the cement, however the initial rate of hydration is slow as the lime needs to initially break down the glassy GGBFS material. Silica and alumina compounds in the GGBFS react with lime to form calcium silicate hydrate and calcium aluminate hydrate – products similar to the primary cementitious materials produced by the cement hydration reaction. The calcium silicate and calcium aluminate hydrates formed in these reactions add to concrete strength and to the refinement of the pore structure of the concrete paste which improves concrete durability performance.

Typical Uses of Slag in Concrete

For Normal Class 20-32 MPa concrete, GGBFS is often used as a 30% replacement for cement. In this situation the slag provides optimal performance in relation to (a) cost, (b) early and later-age strength performance and (c) setting time performance. GGBFS can be used as a 1:1 replacement for cement in these mixes and

later-age strength performance is generally excellent. Workability of the concrete is not greatly affected one way or the other at this replacement level and the increase in setting time is manageable. There can be some increased bleed when GGBFS is used and this can be advantageous in hot weather.

It is not uncommon now, with the wider availability of GGBFS, for ternary mixes to be used in Normal Class concretes – most often for improved economy. Usually, the cement content is kept at about 50% and two SCM's make up the remainder of the cementitious content – typically with fly ash at 20% and GGBFS at 30%. The increased proportion of SCM's in these ternary mixes also means lower early-age strengths. The high reactivity of the GGBFS component usually provides good 28-day strength performance.

For high durability mixes and low heat mixes, cement replacement at levels of 65% and 70% is not uncommon. There has been a large amount of research work carried out in Australia to assess the durability performance of concretes containing high slag replacement levels – in relation to their improved resistance to sulfate attack, chloride ingress and alkali aggregate reaction. A particularly common use of concrete with high slag replacement levels is in low heat/mass concrete applications that are becoming much more prevalent.

One unusual experience with (conventional and geopolymer) concrete containing GGBFS as a cementitious material is the formation of blue or green surface colouring which is evident soon after removal of forms. This colouration is related to the presence of sulfides in the GGBFS and most likely, their interaction with traces of copper, manganese or vanadium from the GGBFS. The colouration typically disappears after a few weeks when surface oxidation due to air exposure occurs, without any detriment to the concrete.

High GGBFS substitution levels also occur with 'paste fill' mixes used in mining operations. These low strength mixes are used to fill mine voids and allow more effective mineral extraction. Where sulfur-bearing ores are involved, the sulfates strongly activate the GGBFS which allows very high early and later-

age strengths to be obtained even with low binder contents.

GGBFS is also a primary material used in a new concrete product known as Envisia™. The binder used in this product includes GGBFS activated by sulfates – a binder type known as super-sulfated cement. The resultant concrete is claimed to provide good plastic and hardened properties and to have a low level of embodied CO₂.

7.6 DURABILITY OF GGBFS CONCRETE

The use of GGBFS as a partial cement replacement material in concrete results in significantly improved durability performance of the concrete – relative to cement-only concrete. The reasons for the improved performance and the actual effects are quite similar for each of the SCM's. Rather than describe the durability-related performance for each SCM separately, a sub-section is dedicated to durability performance (sub-section 9).

8 AMORPHOUS SILICA

8.1 INTRODUCTION

The amorphous silica materials are a class of Supplementary Cementitious Materials (SCM's) more diverse than the other SCM's commonly used in concrete. Their origins are similarly diverse – including naturally occurring minerals associated with volcanic activity and geothermal deposits; waste material resulting from the processing of a common grain (e.g. rice husk ash); and a synthetic product derived from the processing of silicon metal or ferro-silicon alloys (silica fume). The first of the natural occurring minerals were the pozzolanas – harvested from volcanic sources around Pozzuoli (in southern Italy) and used by the Romans in structures that created a paradigm shift in concrete construction. Similar materials were used much later by Smeaton when he built the Eddystone Lighthouse in the UK in about 1759 – a structure that still stands today (albeit in a new location). The success of the

cementitious mix used in this structure led to further experimentation with binder materials and ultimately to the discovery and development of Portland cement in 1824.

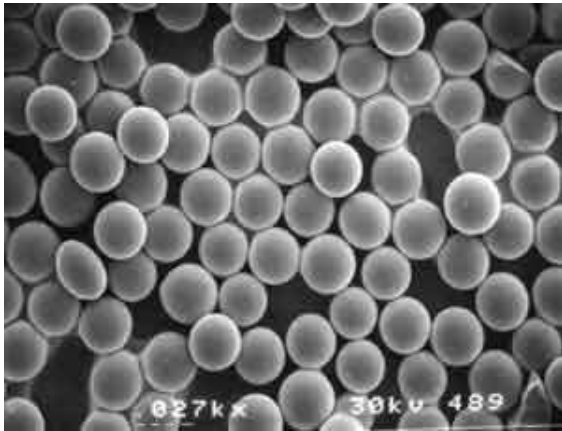

Figure 2.11 – Silica Fume Particles



Figure 2.12 – 'Microsilica' Deposit

The original pozzolanas were of pyroclastic origin – resulting from very fine magma particles being blasted into the air during volcanic activity and then quenched in the relatively cool atmosphere. Known now as pozzolanic materials, the glassy particles contain reactive silica and alumina compounds – which, while possessing little inherent cementitious value alone, can react with calcium hydroxide (lime) in the presence of water to form products with cementitious properties.

Silica fume was first identified as a potential SCM in the 1940's but it wasn't until large scale collection devices came on-line in silicon and ferro-silicon alloy plants in the early 1970's that commercial use was possible. This initial use was in Norway particularly, while in Australia silica fume use began in about 1977. Silica fume sourced from operations in Tasmania and

Western Australia was used in concrete in Australia, but now, most silica fume is imported. The nature and use of silica fume will be discussed in detail below.

In New Zealand, product mined from geothermal deposits near Rotorua (North Island) has been commercialised. These natural materials have been found to improve concrete performance – particularly concrete strength and durability, and to also provide a means of mitigating Alkali Silica Reaction (ASR). This material will also be described in some detail in this sub-section and differentiated from other amorphous silica materials by using the name Microsilica – which is the commercial name used for the New Zealand geothermal product, but which is also sometimes used as a generic name for fine amorphous silica products more generally.

There is a wide variety of amorphous silica materials used throughout the world that have not gained acceptance in Australian or New Zealand concrete markets. These materials include metakaolin, rice husk ash and a variety of glassy materials of geological origin, including (calcined) diatomaceous earth and pitchstone. These materials will not be examined in detail but may be referred to by way of comparison with other amorphous silica products.

8.2 AS 3582.3

The Australian Standard AS 3582.3 provides coverage for all 'amorphous silica' materials – whether naturally occurring or synthetic. While the first version of AS 3582.3 published in 1994 provided specifications for silica fume only, the latest (2016) version covers 'amorphous silica' materials generally.

AS 3582.3 (2016) defines the various amorphous silica SCM's as follows:

Amorphous Silica – very fine pozzolanic material comprised mostly of non-crystalline silica.

Naturally Occurring Amorphous Silica – Refined pozzolanic material – composed mostly of amorphous silica – derived either from hydrothermal alteration of ignimbrite or pumice

breccia or from the extraction of precipitated silica from geothermal water – and supplied as either powdered, slurried or pre-wetted compressed filter cake – these varying in solids and moisture contents.

Silica Fume – Very fine pozzolanic material comprised mostly of amorphous silica produced by electric arc furnaces – a by-product of elemental silicon or ferro silica alloy production – and supplied in several forms including undensified (bulk density $\leq 400 \text{ kg.m}^{-3}$), densified (bulk density $\geq 400 \text{ kg.m}^{-3}$) or slurried (typically 40-60% silica fume by weight).

AS 3582.3 nominates eight compositional and performance properties but only provides limits for four of them. The four limits describe chemical compositional requirements. The Standard does not set any limits for physical (e.g. Fineness) or performance (e.g. Relative water requirement or Strength Index) characteristics. The nominated suite of compositional and performance properties from AS 3582.3 is shown in **Table 2.8**.

While the Standard does not require that a product be tested in concrete to ensure that it is suitable, it does differentiate between ‘Proven’ and ‘Unproven’ amorphous silica sources. ‘Unproven’ sources need to be tested at a higher frequency (for a period of three months) until there is confidence in the quality and consistency of the material. While not all nominated properties have limits defined in the Standard, purchasers may request test data for any (or all) of the nominated properties.

8.3 AMORPHOUS SILICA PRODUCTION AND PROCESSING

The wide variety of materials in the ‘amorphous silica’ class necessitates separate consideration of the nature and extent of processing required for each material type. As with all raw materials for use in concrete, the key processing considerations are (a) meeting Standard or specification requirements, and (b) providing a product of consistent quality.

Table 2.8 – Properties Nominated in AS 3582.3 (2016)

Property	Limit	Reference Test Method
Total Silica Content (SiO ₂) (%)	>85	AS 2350.2
Loss on Ignition (% maximum)	6.0*	AS 3583.3
Moisture Content (% maximum)	3.0**	AS 3583.2
Sulfate (as SO ₃) (% maximum)	3.0	AS 3583.8
Bulk Density	-	***
Surface Area	-	****
Chloride Ion Content (% maximum)	-	AS 3583.13
Strength Index (% minimum)	-	AS 3583.6

NOTES:

- * may exceed 6.0% if Strength Index is acceptable;
- ** limit does not apply to slurried products;
- *** method defined in Standard;
- **** to be carried out in accordance with ASTM C1069.

Silica Fume

Silica fume is a by-product of the production of silicon metal or ferro-silicon alloys in electric blast furnaces. In these processes, silica sand (quartz) is fed into the blast furnace with coke, coal and wood chips. These materials are reacted at temperatures of about 2,000°C to produce the silicon product, with very fine silica fume being produced as a by-product of the reactions. Decades ago, the smoke-like silica fume fines were released into the atmosphere. In the 1970’s more substantial environmental regulations required that the fines be collected in fabric filters which allowed the silica fume to be recovered and made available for use in the concrete industry.

Silica fume as produced is an extremely fine material and is comprised primarily of high purity (typically >95%) amorphous silicon dioxide (SiO₂). A small proportion of crystalline SiO₂ is also produced. The level of crystalline silica varies dependent on the manufacturer, with reported levels of from <0.05% to <0.5%. The physical characteristics of the silica fume product are:

- Particle Sizing: 95% <1 µm;
- SG: about 2.2;
- Specific Surface Area: 15-30 m²/g;
- Bulk Density:
 - 130-430 kg.m⁻³ (as produced);
 - 480-720 kg.m⁻³ (densified).

Silica fume as produced is very light, and to improve its handling characteristics and transportability, it needs to be densified. i.e. agglomerating the fine particles into larger 'lumps'. This then creates a need to ensure that, when using the densified product in concrete, the material is de-agglomerated to ensure full value is achieved. To improve its ease of handling, silica fume can also be supplied in a slurried form – these slurries sometimes containing a super-plasticiser. They are not now widely used. Undensified silica fume may be used in bagged cement-based products or in applications where mix designs require little or no coarse aggregate – a situation where de-agglomerating densified silica fume is more difficult.

Microsilica

In New Zealand, natural amorphous silica deposits in the Rotorua district have been commercialised. These deposits are hosted in hydrothermally altered rhyolitic rocks – Mamuka Ignimbrites and Rotoiti Breccia – estimated to be 60,000 to 200,000 years old. The deposits have been extensively altered geologically, with widespread silification. The product is mined, ground and blended to achieve a product of high quality with consistent physical and chemical properties. The product has a SiO₂ content of 85-90%, being mainly amorphous silica but containing a small proportion of crystalline quartz and cristobalite. It has a bulk density of about 500-600 kg.m⁻³ and an average particle size of about 2 µm.

Metakaolin

Metakaolin is a fine, amorphous, aluminosilicate SCM that is made by calcining pure or refined kaolinitic clay at a temperature of 650-800°C, and then grinding it to a specific surface area of about 700-900 m²/kg resulting in an average particle size of about 3 µm. The product is a highly reactive SCM.

Rice Husk Ash

A reactive pozzolanic material is produced when rice husks are burned under controlled conditions – typically at 500-700°C. The resultant material has a SiO₂ content of about 80% and contains both amorphous and crystalline silica particles. The average particle size can be quite high (about 50 µm), but because of the highly porous structure of the product it can have an extremely high surface area (up to 50-60,000 m²/kg), which makes it highly reactive. The need to closely control the burning conditions limits the practicality of producing the product in many regions, and particularly in under-developed countries.

Natural Pozzolans

There is a wide variety of natural pozzolan materials used throughout the world, with a variety of origins. Many are of volcanic origin and the glassy deposits may be 'incoherent' layers of glassy material or compacted materials (known as tuffs) that may have been chemically altered by later geological activity. Some sedimentary materials (clays and diatomaceous earths) also demonstrate strong pozzolanic behaviour. In the main these materials are glassy, silico-aluminate compounds and often with significant porosity. They can contain small proportions of crystalline silica as well as quite high alkali contents. The materials can be mined and milled into fine powders for use in concrete and related applications. There has been little interest in this class of pozzolans in Australia, although some research work has been done to assess the potential for use in concrete of a glassy pitchstone material found in North Queensland.

8.4 AMORPHOUS SILICA CHARACTERISATION

The variety of natural and synthetic sources of amorphous silica materials results in a wide range of material properties and reactivities. While synthetic materials derive from highly controlled manufacturing processes and are expected to be quite consistent, the properties of the natural materials reflect the diversity of their sourcing. Many of the key physical

properties result from processing activities that have been described above. The significance of the physical properties is discussed below, and a comparison of key properties is given in **Table 2.9** to allow a comparison of these materials to be made.

Physical Characterisation

Surface Area – The specific surface area (SSA) of amorphous silica materials is a function of the processes from which they are derived and is fundamental to their performance in concrete. The SSA is typically measured using the BET method, and the results give values very much higher than those for Type GP cement or more conventional SCM's. High levels of pozzolanic reactivity and increased (relative) water requirement are a consequence of the very high surface areas. For some of these fine materials, where agglomeration is a problem, conventional 'fineness' testing using a 45-micron screen is also used as a measure of the degree of agglomeration. For silica fume, the American ASTM C 1240 Standard sets a maximum of 10% retained on the 45-micron screen to limit the degree of agglomeration, as well as a minimum SSA of 15 m²/kg to ensure adequate reactivity.

Average Particle Size – In general this value is related to the SSA, but for some of the amorphous silica materials, high SSA values come about because of the porous structure of the material. Rice Husk Ash (RHA) is an example of a relatively coarse material having a high SSA because of its highly porous structure. For silica fume, the MMD is about 0.1-0.2 µm.

Relative Density or Specific Gravity (SG) – This is not a specified property in either the Australian Standard or most international Standards. The SG is a function of the chemistry and mineralogy of the material and is used in mix designs to convert mass to volume. For silica fume the SG is about 2.1-2.2.

Bulk Density – This property is important from handling, transport and packaging perspectives. The very low bulk density of silica fume as produced creates difficulties in handling and transporting the product. Densification of the product, effectively an

agglomeration process, assists with handling but creates potential problems when using the material in concrete. Unless the product is effectively de-agglomerated during concrete mixing its full pozzolanic activity potential will not be realised.

Water Requirement and Strength Index

These complementary properties affect the strength able to be achieved when using the product in concrete. A high SSA generally means an increased water demand in concrete and this needs to be mitigated using admixtures. The high SSA also means high reactivity and concrete strength performance is generally much higher than with conventional SCM's. Typical of the test methods used to assess these properties are those described in AS 3583.6. This test involves the preparation of mortars containing (a) cement only – the control mortar, and (b) cement plus a proportion of the test material – the test mortar. The amount of water required to achieve a similar flow to the control mortar allows calculation of the (relative) Water Requirement, while the strength of the test mortar (at either 7 days under accelerated curing, or 28 days under standard curing) allows calculation of the (Strength) Activity Index.

Mineral and Chemical Characterisation

The amorphous silica materials are either silica-rich or silico-aluminate rich materials derived primarily from geological sources. To ensure adequate levels of pozzolanic activity these materials must be mainly amorphous. Given their geological origin, many amorphous silica products contain small proportions of crystalline silica minerals (quartz and cristobalite) which must be given proper consideration when handling and using the products (see 'Handling and Storage' below). Key chemical parameters used to characterise the amorphous silica materials are those that potentially impact end-use performance. These include overall chemical composition and some individual components, as described below.

Chemical Composition (General)

– Determined using AS 2350.2, this information is primarily used to assess the SiO₂ content – for which a minimum value (85%) is set in almost all national Standards. For a product like silica fume that derives from a well-controlled

industrial process, variations in chemistry would be expected to be small. For potentially more variable materials of geological origin, chemical content provides a simple measure of product consistency.

Sulfate – Determined using either AS 3583.8 or AS 2350.2, the sulfate content is an important property when using SCM's in concrete as high levels of sulfate may contribute to expansive reactions in concrete and these may result in concrete cracking.

Alkalis – While AS 3582.3 does not set any limits for alkali content, it requires that any determination of total alkali or available alkali content be carried out using methods AS 2350.2 or AS 3583.12 respectively. The total alkali content may provide useful information if needed to assess likely susceptibility of a concrete mix to ASR if reactive aggregates are being used in the mix.

Chloride – Limits for chloride are set in AS 3582.3. Able to be determined using either AS 3583.13 or AS 2350.2, the chloride ion content is useful in helping determine the overall amount of chloride in a concrete mix, along with the chloride ion content of cement, admixtures and aggregate materials. Chloride ions may migrate through the concrete over time and, if and when they reach any embedded steel, may initiate and/or accelerate corrosion of the steel.

Moisture Content – Determined using AS 3583.2, this test measures the amount of moisture adsorbed on the surface or in the pores of the material. The moisture content, if too high, may affect the free-flowing nature of a material and in more severe circumstances may result in the formation of lumps.

Loss on Ignition (LOI) – Determined using AS 3583.3, the LOI test measures the amount of unburned carbon remaining in the product. This test provides useful information about

silica fume (where carbon electrodes are used in the silicon / ferro-silicon manufacturing process) and for Rice Husk Ash (which is produced in a combustion process).

8.5 AMORPHOUS SILICA USES

Australian experience with amorphous silica products is limited to local and imported silica fume, while in New Zealand the locally produced Microsilica product and imported silica fume have been used. In Australia, recent data suggests that silica fume use is about 15,000 tpa. Silica fume and Microsilica are used for two primary reasons, namely (a) to reduce Portland cement content for economic reasons, and (b) to produce high strength / high durability concrete. Most of the current use of silica fume is for the latter reason.

Silica fume is highly reactive pozzolan with a cementitious efficiency nominally between 2 and 5 times that of Type GP cement – dependent in part on the overall cementitious content of the mix and the proportion of silica fume. Silica fume is not often used at a cement replacement rate of greater than 8-10% as concrete mixes can become very sticky and difficult to place and finish at higher replacement levels. Almost invariably, silica fume mixes require a super-plasticiser to provide reasonable workability, however care needs to be taken to ensure that total water is not reduced to a point where it might affect strength development. Highly cohesive silica fume mixes generally have a lower susceptibility to segregation. Another noticeable property of concrete containing silica fume is the very low bleed level and rate. This needs to be understood and managed for any flat-work applications.

Table 2.9 – Physical Properties of Amorphous Silica Products

Property	Silica Fume		Microsilica	Metakaolin	Rice Husk Ash	Natural Pozzolans
	Un-Densified	Densified				
Specific Surface Area (m ² /g)	15-30	15-30	-	8-15	50	variable
Average Particle Size (µm)	0.2	0.2	2.0	1.0	11-30	variable
S.G.	2.2	2.2	2.15-2.3	2.4-2.6	2.1	2.3-2.6
Bulk Density (kg.m ⁻³)	130-430	480-720	500-600	600	500	1,000-1,400
Water Requirement	increased	increased	increased	increased	increased	increased
Activity Index (%)	120	120	108	120	120	variable

Silica fume reacts strongly and relatively quickly with lime present in the concrete paste, and this has led to concerns about a reduction in concrete paste pH sufficient to compromise the passivation of any embedded steel in the concrete. Testing on mature cement pastes has shown that 10% silica fume can reduce the paste pH by 0.5 pH units, while 20% silica fume can reduce the pH by 1.0. Even with the higher proportion of silica fume the paste pH remained above 12.5 and steel passivation is not compromised at this level.

Silica fume imparts high durability performance in part because of the high concrete strengths that are able to be achieved, and in part because of the ability of the very fine particles to alter the nature of the cement paste-aggregate interface – a known source of weakness in concrete. Arguably, silica fume dose rates of ≤5% are far less effective at improving strength and durability because there is insufficient material to properly enhance performance at the paste-aggregate interface.

Early-age concrete strengths with silica fume mixes are high because of its rapid hydration and because of the physical filler effect. The reaction can be so rapid that it can use up available mix water leading to 'self-desiccation'. The dense early-age microstructure also makes it difficult for external water to enter the concrete to assist with curing. While some laboratory studies have suggested that the early-age high strengths can lead to

some strength regression at later ages, this has not been borne out in field studies.

From a commercial perspective, silica fume is quite expensive relative to Type GP cement and other SCM's.

Microsilica, although not as fine as silica fume, performs in a very similar manner. One advantage of Microsilica over silica fume is that it does not have issues with agglomeration that are common with silica fume. Microsilica has a shelf life, without suffering agglomeration, of at least four years. Despite this, care still needs to be taken to ensure adequate dispersion of the Microsilica through the concrete mix. Appropriate replacement rates are also considered to be 8-10% and the primary use of Microsilica is in high strength and high durability concrete applications. Amorphous silica materials were first used in the 1950's and 1960's in a series of dam constructions in the North Island of New Zealand, prior to the development of the current Microsilica deposits. Microsilica is not as fine as silica fume and appears to have less detrimental effects on concrete workability. It can give a slight reduction in setting time despite the usual presence of a super-plasticiser.

Microsilica also attracts premium pricing.

Typical Uses of Silica Fume / Microsilica in Concrete

Typically, silica fume / Microsilica are used for the primary purposes of obtaining high strength

and superior durability performance in concrete. Some special applications of note are (a) those requiring low heat, where the ability to reduce cement content and still obtain high early-age strengths is critical, and (b) where high strength and highly cohesive mixes are required (e.g. sprayed concrete/shotcrete used in mining situations).

The wide-spread use of silica fume in the USA has led to the preparation of several guidance documents in addition to their Standard (ASTM C 1240), including:

- AASHTO Designation M307-04 – *Standard Specification for Use of Silica Fume as an Admixture in Hydraulic Cement Concrete, Mortar and Grout*; and
- ACI 234-R – *Guide for the Use of Silica Fume in Concrete*.

The use of Silica fume and Microsilica results in improvements to a range of concrete properties as described below. It has been noted that, because of the high degree of cohesiveness found with silica fume mixes, concrete slump targets of 25 mm to 50 mm higher than those used for cement-only mixes are necessary in order to achieve similar levels of compaction.

Compressive Strength – Test work carried out on Australian silica fume involving comparisons with silica fume sourced from Europe showed that (a) the performance of the materials was similar, regardless of source, and (b) 28-day concrete strengths for silica fume mixes containing 350 kg of cementitious material were 15% higher than a cement-only control (43 MPa at 28 days) at 5% replacement level; 35% higher than the control at 10% replacement level; and 40% higher than the control at 15% replacement level. At higher cementitious contents the proportional improvement is expected to be lower. In a separate study with higher cementitious contents and higher strengths, improvement of 25% and 35% were noted against a control that yielded 56 MPa at 28 days. For Microsilica, trials demonstrated increases in 28-day strength of 15-30% against a cement-only control with Microsilica additions of 7% and 10%. It has also been noted that the modulus of elasticity of concrete containing silica fume is higher than concrete of similar strength containing cement only.

Drying Shrinkage – Differing views appear in the literature regarding the drying shrinkage of concrete containing silica fume. An increase in drying shrinkage of about 15% has been reported in one study, while elsewhere lower and slower drying shrinkage has been noted. This suggests the need for trials to be carried out if specific drying shrinkage performance is required as the outcome will be dependent on a variety of factors. Testing of Microsilica showed that slightly higher drying shrinkage was observed at one year against a cement-only control.

Pore Structure – The durability performance of concrete is determined to a large extent by the pore structure and the consequent permeability of the concrete. Mercury porosimetry testing carried out on concrete containing Australian silica fume showed reduced levels of total porosity and a reduction in the number of larger pores – both indicative of reduced permeability. Other testing confirms the reduction in concrete permeability, at least at up to a 10% cement replacement level, with dramatic reductions in permeability being noted with both silica fume alone or when used in combination with other SCM's.

Chloride Ion Permeability – With silica fume there are several factors at play in relation to chloride ion penetration, most particularly the much lower permeability of concrete containing silica fume and the consequent slower diffusion rate of chloride ions. This lower diffusion rate counters concerns about increased corrosion risk due to the slight lowering of paste pH as a result of the silica fume / lime reaction in the paste. The increased resistivity of concrete containing silica fume also assists in reducing corrosion rates if corrosion is initiated. When using Microsilica, concrete containing 10% Microsilica was found to have significantly lower electrical conductance when assessed using the ASTM C1202 Rapid Chloride Permeability Test.

Sulfate Resistance – The use of silica fume concrete has been found to be as effective as using Type SR cements to prevent sulfate attack, and if used in combination with fly ash or GGBFS, is even more effective than Type SR cements. The improved resistance is likely due to (a) the refined pore structure, and (b) the

lower lime content. Testing with Microsilica using the ASTM C 1012 method has shown very significant improvements in sulfate resistance against a cement-only control.

Alkali Silica Reaction (ASR) – One of the first commercial uses of silica fume was for the control of ASR in Iceland, where since 1979, all concrete has included about 7% replacement of cement with silica fume. This has proved to be a very effective solution. Silica fume acts in several ways to mitigate ASR – by (a) reacting with, and binding, available alkalis and (b) reducing water ingress because of lower concrete permeability. It has been reported that agglomerated silica fume may act as an initiator of ASR, so care must be taken to ensure efficient mixing and complete distribution of the silica fume. In New Zealand where ASR has been problematic, natural mineral materials like diatomite and pumicite were used in the 1950's and 1960's to mitigate ASR until, in the 1990's, both Microsilica and meta-kaolin were introduced for ASR mitigation. A substantial Australian review of ASR and its control suggests that 8-10% silica fume is sufficient to mitigate ASR.

Carbonation – Carbonation does not appear to be a significant issue with high strength concretes containing silica fume, but with lower strength concrete it may be problematic, particularly if there has been inadequate concrete curing.

Applications of Other Amorphous Silica Materials

Where silica fume, fly ash and GGBFS are not readily available, natural pozzolans are used as cement replacement materials and for concrete durability improvement where required. Some of these materials increase concrete water demand. Some materials are used after simply mining and milling them to an appropriate fineness, while others are subjected to 'calcination' – heating (to 500-800°C) to activate certain (clay) minerals. Activated products like meta-kaolin are highly reactive and are used in both conventional concrete and in the manufacture of 'geopolymer concrete'. In Australia, some research has been carried out on the cementitious efficiency of pitchstone – a glassy mineral found in large outcrops. There are an estimated 100 million tonnes of

pitchstone available in North Queensland. This mineral can be mined and milled to a fine powder and behaves as a moderately cementitious material and has been shown to improve concrete durability.

Low Heat Applications – While silica fume has almost the same contribution to concrete heat of hydration as Type GP cement on a unit weight basis, the higher strengths able to be achieved and the consequent lower cementitious content requirements mean silica fume has a role in low heat applications, often in combination with other SCM's like fly ash.

Sprayed Concrete Applications – Silica fume is a key ingredient in sprayed concrete (or Shotcrete) which is used particularly for tunnel linings and in mines. Silica fume concrete, alone or with steel fibres included, provides cohesive, high early strength concrete that is particularly suitable for sprayed concrete applications such as those comprehensively described in the American Concrete Institute 'Guide to Shotcrete'.

Special Amorphous Silica Applications – One of the main benefits of silica fume is the ability to make very high strength concrete, typically 80-100 MPa and above. With these very high strengths comes a high modulus which can be used to advantage in high rise structures in particular. These performance characteristics allow thinner columns to be used and create additional savings in materials through the need for less concrete and reinforcing steel.

High durability performance also makes silica fume concrete the material of choice in projects requiring a long (e.g. 100 year) design life – and was the SCM of choice for some Scandinavian bridge structures and tall Middle Eastern tower buildings.

Metakaolin is a suitable raw material for the manufacture of 'geopolymer concrete'. With its high reactivity it has the potential to impart good strength and durability performance characteristics to this alternative to conventional concrete.

8.6 HANDLING AND STORAGE

Like other SCM's, powdered amorphous silica products should be kept dry to facilitate effective handling, batching and transport.

Silica fume as produced is a very fine powder of very low bulk density – so low that it compromises effective handling and batching. This necessitates that silica fume be densified (by agglomerating particles), to increase its bulk density from $<400 \text{ kg.m}^{-3}$ to values in the order of 700 kg.m^{-3} . In the past, slurries of silica fume have also been used to improve its handling characteristics though these are not common now. Densified silica fume must be de-agglomerated once batched into a concrete mix to (a) ensure its efficiency is maximised, and (b) prevent the possibility of agglomerations acting as a nucleus for ASR.

Microsilica, while very fine, has been 'designed' to ensure that agglomeration does not occur. It is claimed that even after four years, no agglomeration of the product is observed.

As is the case for the other fine SCM products, care must be taken in the workplace to ensure that dust levels are properly managed. All amorphous silica products contain significant proportions of respirable material. For most of the products, particularly Microsilica and many of the natural amorphous silica products, they contain (generally) low levels of crystalline silica and need to be treated with considerable caution in terms of workplace exposure to dust. In potentially high exposure areas involving the use of 'amorphous silica', engineering systems should be used to manage ambient dust levels, and as a last resort, PPE should be worn to limit personal exposure levels.

While silica fume is often described as an amorphous product, effectively all Safety Data Sheets for silica fume note some (small) proportion of crystalline silica. With the current levels of concern about crystalline silica and recognising the extremely high fineness of the product, proper control measures should be put in place to manage exposure to silica fume and amorphous silica dust.

8.7 DURABILITY OF AMORPHOUS SILICA CONCRETE

The use of amorphous silica products as partial cement replacement material in concrete results in significantly improved durability performance of the concrete – relative to cement-only concrete. The reasons for the improved performance and the actual effects are quite similar for each of the SCM's. Rather than describe the durability-related performance for each SCM separately, a sub-section is dedicated to durability performance (sub- Section 9).

9 THE EFFECTS OF SCM'S ON CONCRETE DURABILITY

9.1 INTRODUCTION

Concrete that is able to provide high durability performance is generally characterised by having high strength – which in turn generally means a relatively high cement (plus SCM) content and a low water/cementitious ratio. These characteristics impart properties of low porosity and low permeability which are conducive to preventing aggressive fluids from entering the concrete and reacting, in one way or another, with components of the cement paste and/or embedded steel. The effectiveness of water/cementitious ratio on porosity and permeability are shown in **Figures 2.13** and **2.14**.

It is readily able to be shown that the use of SCM's as partial cement replacements – the levels of replacement varying with SCM type – is able to improve durability performance through several mechanisms, including:

- By reacting with lime, in the presence of water, to form additional hydration products that lower both porosity and permeability;
- By, in some cases, significantly increasing the volume of paste in the mix because of the (relatively) low density of the SCM creating a higher paste volume (fly ash and silica fume particularly);
- By way of fine SCM particulates blocking

- pores in the paste; and
- By increasing the reactive silica content in the paste beyond the 'pessimism level' resulting in reduced (ASR) gel expansion.

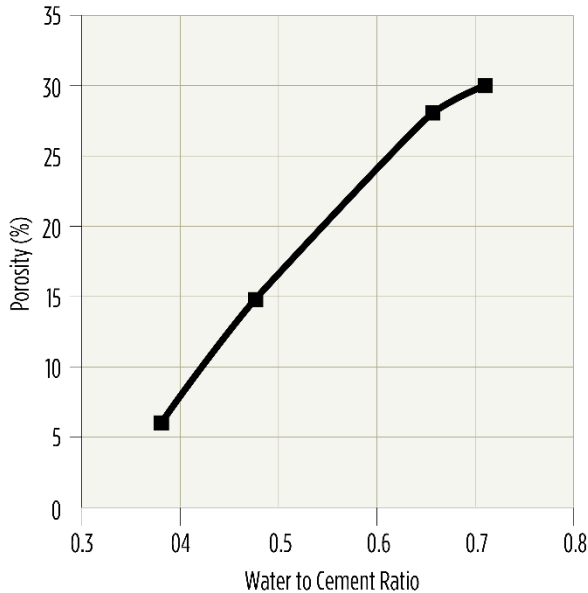

Figure 2.13 – Effect of W/C Ratio on Concrete Porosity

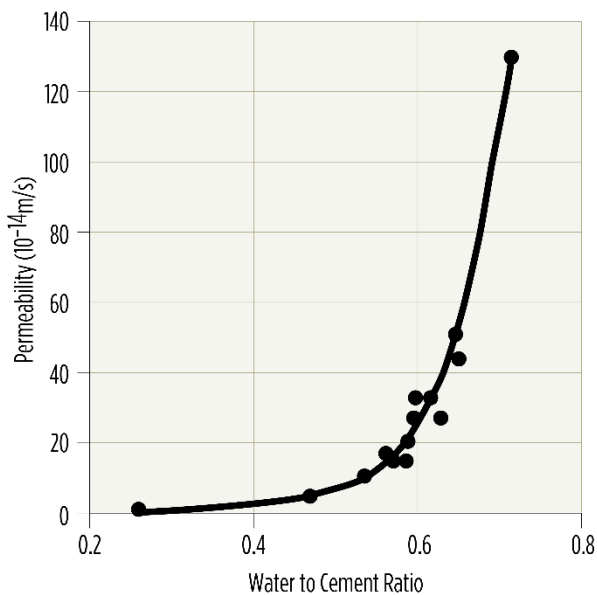

Figure 2.14 – Effect of W/C Ratio on Concrete Permeability

The extent of this improved performance and the effect of SCM proportion will be demonstrated with selective examples for each of the important concrete durability performance characteristics in the following sub-sections.

9.2 DURABILITY PERFORMANCE IMPROVEMENT EXAMPLES

Chloride Ion Permeability – Chloride ions may be found within the paste – their source being the materials used in concrete manufacture, **or** the chloride may derive from external sources as exemplified by the concrete (a) being submerged in sea water or (b) having airborne salts deposited on the surface in locations adjacent to the ocean. Regardless of the source, chloride ions will slowly but surely penetrate into the body of the concrete and ultimately destroy the passivated layer on any embedded steel and initiate corrosion. The rate of penetration of the chloride ions will be determined, in part, by the permeability of the concrete. Assuming that the fundamental concrete performance is adequate (sufficiently high strength, sufficiently low water/cementitious ratio), the use of SCM's will provide high durability performance through creating additional resistance to chloride ion penetration. The effectiveness of the SCM is determined in part by its substitution rate. Typically, fly ash is used at 25% replacement; GGBFS at 65% replacement; and silica fume at 8-10% replacement in high durability concrete mixes. Examples of the effectiveness are shown in **Figures 2.15** and **2.16** for fly ash and GGBFS respectively.

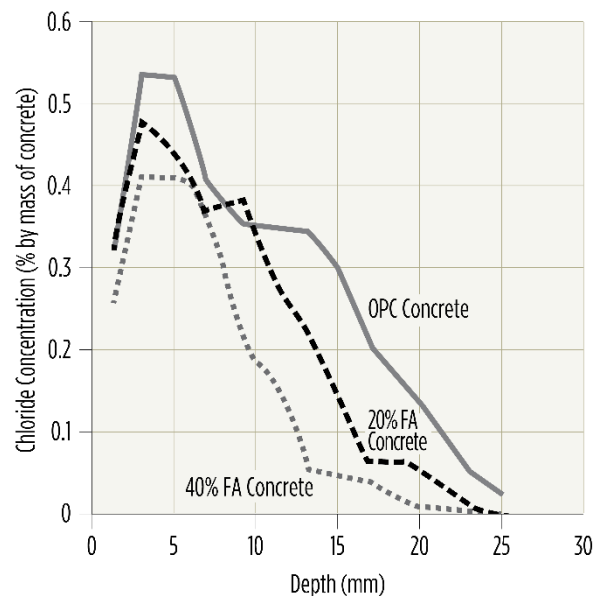

Figure 2.15 – Fly Ash Proportion and Chloride Ingress

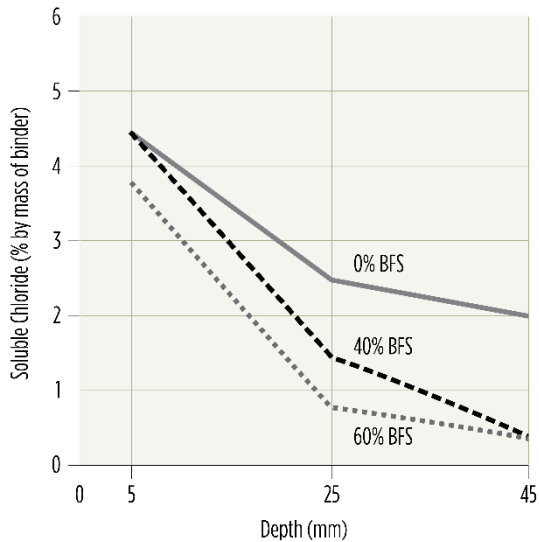

Figure 2.16 - GGBFS Proportion and Chloride Ingress

Sulfate Resistance – Sulfates may attack concrete paste in several ways, including reacting with lime or other constituents to form expansive compounds that then cause cracking, or by attacking the calcium silicate hydrate component and causing it to disintegrate and the concrete to crumble. In each case, decreasing concrete permeability is a key element to increasing concrete sulfate resistance. Examples of the effect are shown in Figures 2.17 and 2.18.

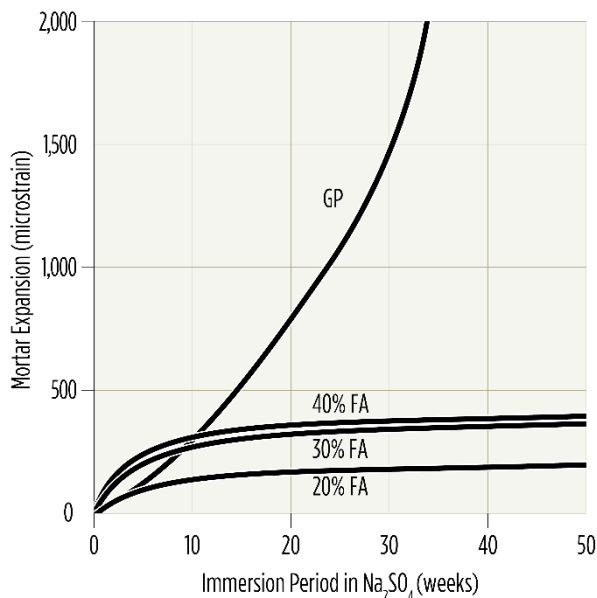

Figure 2.17 – Fly Ash Proportion and Sulfate Resistance

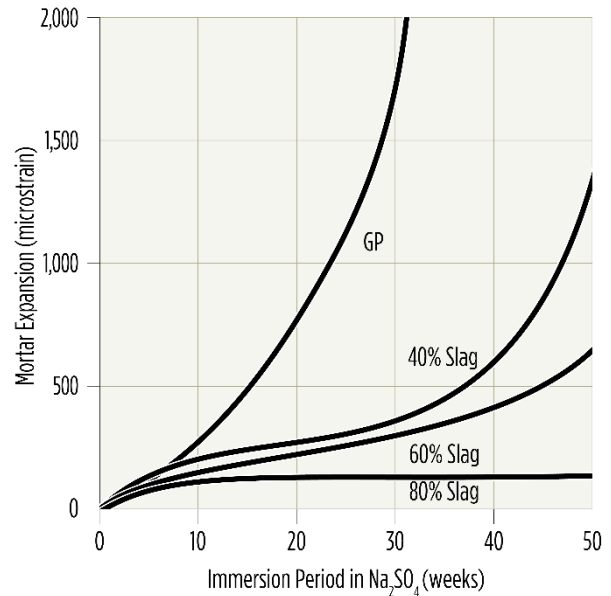

Figure 2.18 – GGBFS Proportion and Sulfate Resistance

Drying Shrinkage – Drying shrinkage results from the long-term loss of moisture from the concrete paste due to atmospheric drying conditions. Levels of drying shrinkage are not determined by any single factor, and the nature of the cementitious material has little influence – other than in the test used to measure drying shrinkage performance for cements when conformance with Type SL requirements in AS 3972 are considered. Fly ash in particular has a significant effect on drying shrinkage of the mortar used in the test described in AS 2350.13. GGBFS also generally results in lower drying shrinkage based on this test. Typically, a Type GP cement will lead to a mortar drying shrinkage of about 600 microstrain, while Type GB cements containing either fly ash or GGBFS lead to a drying shrinkage value of about 250-300 microstrain with the AS 2350.13 test.

As noted in Table 1 of AS 3972, there are multiple factors involved in determining concrete drying shrinkage, and all need to be considered.

Heat of Hydration – The hydration of cement produces heat as a by-product and for mass concrete structures, this can be problematic. Low heat (Type LH) cements are useful in dealing with high concrete temperatures (and temperature differentials) and are routinely employed. SCM's are used to effectively dilute

Type GP cement in a conforming Type LH cement – the effectiveness of the SCM dependent largely on the replacement proportion, as shown for GGBFS in **Figure 2.19**. In commercial type LH cements, either 40% fly ash or 65% GGBFS replacement rates are used. Silica fume is not generally used for Type LH cement manufacture.

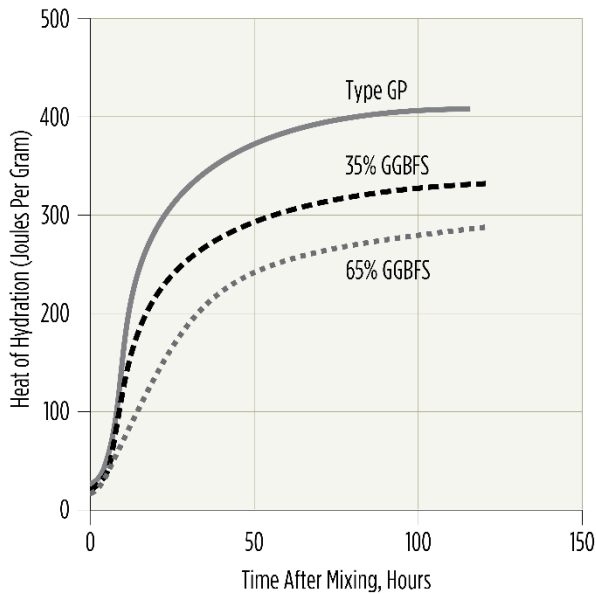

Figure 2.19 – The Effect of Increasing Proportions of an SCM on Heat of Hydration

ASR / AAR – Alkali aggregate or alkali silicate reaction is a significant issue for concrete durability for various reasons, including (a) it often occurs in significant infrastructure, and (b) it does not generally appear for 20 or more years and is practically impossible to remediate.

ASR/AAR requires there to be (a) reactive aggregate, (b) sufficient alkali to initiate ASR/AAR, and (c) sufficient water ingress to cause the ASR/AAR gel to expand and cause concrete cracking. SCM's are able to mitigate the likelihood of ASR/AAR by two primary means, namely (1) providing fine reactive silica evenly dispersed through the concrete paste to (effectively) react with the available alkali, and (2) reduce concrete permeability to prevent sufficient water entering the structure to allow any ASR/AAR gel to expand.

All of the common SCM's are effective in mitigating ASR/AAR, but at different replacement levels. Fly ash is typically used at

25%; GGBFS is used at 50+%; while silica fume is used at 8-10%. For silica fume, the replacement proportion and the percentage of silica in the product are both determinants of its effectiveness in mitigating ASR/AAR (see **Figure 2.20**). **Figure 2.21** shows the reduction in expansion obtained from increasing the reactive silica level beyond the 'pessimism level'.

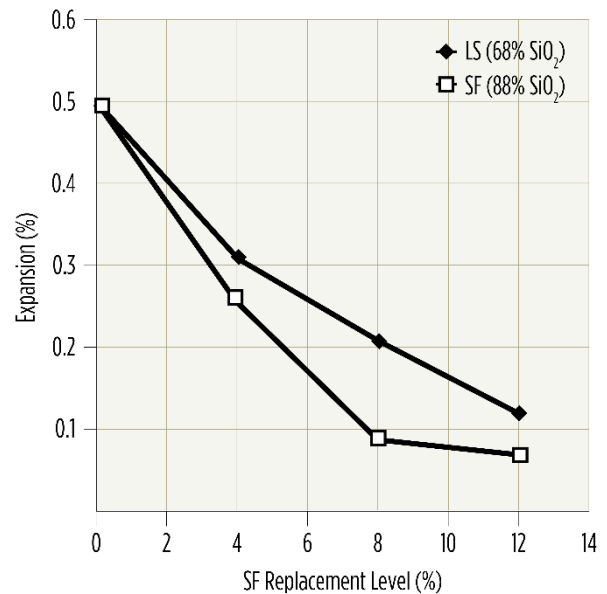

Figure 2.20 – Effect of Silica Fume Proportion and SiO₂ Content on Expansion Due to ASR

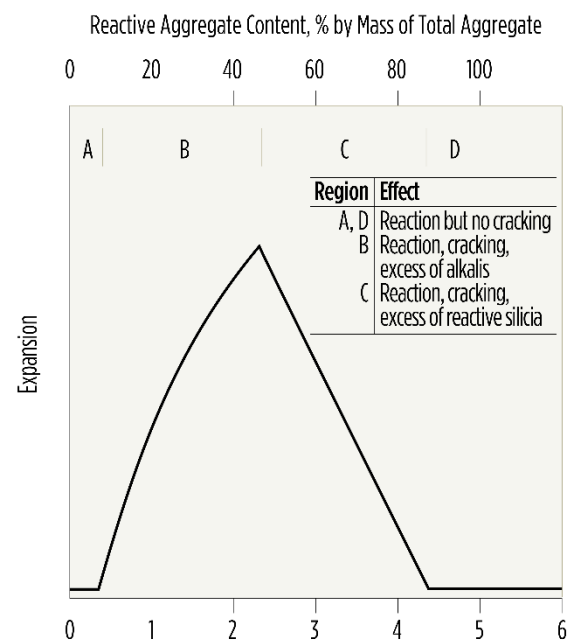

Figure 2.21 – Effect of Reactive Silica Content on Expansion Due to ASR

It should be noted that research has established that if silica fume is present in an agglomerated form it may initiate ASR/AAR. This emphasises the need to ensure that silica fume is fully dispersed through a concrete mix.

10 SUMMARY

SCM's, and most particularly fly ash and GGBFS, are now commonly used and fully accepted cementitious materials for use in concrete manufacture in Australia. Silica fume is less widely used as it is quite expensive – however, in specific end-uses it is particularly effective (e.g. high strength and high durability applications, shotcrete).

Although these SCM's derive from materials which are nominally 'wastes' from large scale industrial processes, once processed they become reliable and consistent cementitious materials. There are Australian Standards (the AS 3582 series) specific to each of these material types.

SCM's give improved performance in almost all aspects of concrete performance. Generally, they improve workability and pumpability of plastic concrete as well as strength and durability performance improvement in hardened concrete. A huge amount of research has been carried out to substantiate these improvements and to understand the mechanisms that drive them.

A key element of SCM use in modern concrete is the positive benefit of reducing the embodied CO₂ and embodied energy levels in concrete which is a critical requirement for modern construction materials. Fly ash and GGBFS can also be used in 'alternative binder' materials which can substitute for Type GP cement in certain applications.

In a variety of different ways, SCM's will continue to be important concrete materials and to make an ongoing positive contribution to all aspects of concrete technology.

11 RELEVANT AUSTRALIAN STANDARDS

- 1) AS 1379 – *The specification and supply of concrete*
- 2) AS 2758 – *Aggregates and rock for engineering purposes*
- 3) AS 2758.1 – *Concrete aggregates*
- 4) AS 3600 – *Concrete structures*
- 5) AS 3972 – *General purpose and blended cements*
- 6) AS 2350 – *Test methods for general purpose and blended cements (series of Standards)*
- 7) AS 3582 – *Supplementary cementitious materials (series of Standards)*
- 8) AS 3582.1 – *Fly ash*
- 9) AS 3582.2 – *Ground granulated blast furnace slag*
- 10) AS 3583.3 – *Amorphous silica*
- 11) AS 3583 – *Test methods for supplementary cementitious materials (series of Standards)*

12 FURTHER READING

- 1) Neville, A.M. '*Properties of Concrete*' (4th Edition) (1995), Longman Group Limited, ISBN 0 582 23070 5
- 2) CCAA Technical Notes – TN 77 (Fly Ash); TN 78 (GGBFS); TN 79 (Amorphous Silica); TN 59 (Cements)
- 3) CSIRO, '*Guidelines for the use of High-Volume Fly Ash Concrete*' (1995), ISBN 0 643 05822 2
- 4) Standards Australia, '*Alkali Aggregate Reaction – Guidelines on minimising damage to concrete structures in Australia*' (2015), SA HB 79-2015, ISBN 9 781 76035 060 4
- 5) Ash Development Association of Australia, '*Coal Combustion Products Handbook*' (2nd Edition) (2014), ISBN 9 780 992514 006

CONTENTS

1	OUTLINE	2
2	TYPES AND USES OF AGGREGATES...2	
3	SOURCES OF AGGREGATES	4
3.1	GENERAL	4
3.2	NATURAL SANDS AND GRAVELS	4
3.3	CRUSHED ROCK AGGREGATE....	4
3.4	MANUFACTURED AGGREGATE...5	
4	AGGREGATE PROPERTIES IN AS	
2758.1	6
4.1	GENERAL	6
4.2	GRADING.....	6
4.3	PARTICLE SHAPE AND SURFACE TEXTURE.....	8
4.4	PARTICLE DENSITY AND WATER ABSORPTION	9
4.5	AGGREGATE STRENGTH AND DURABILITY	10
4.6	AGGREGATE CHEMICAL RESISTANCE AND DURABILITY .	12
5	OTHER PROPERTIES	14
5.1	GENERAL	14
5.2	THERMAL EXPANSION.....	15
5.3	COLOUR.....	15
6	SUMMARY OF AGGREGATE	
	SPECIFICATIONS	15
7	REFERENCES.....	20

1 OUTLINE

This section summarises information on the properties of aggregates, their sources in Australia, and their classification for use in concrete. It discusses their properties in some detail and their influence on the properties of the concrete. It also outlines methods of testing aggregates.

Aggregates form between 60% and 80% of the volume of concrete and are an important constituent of concrete. At one time they were considered to be inert fillers, but we now know their properties can significantly affect the

performance of concrete in both its plastic and hardened conditions.

The physical and chemical test methods for the properties of concrete aggregates are covered by Australian Standards including AS 1141 and AS 1012. The specifications for concrete aggregates are covered by AS 2758.1.

AS 1141 contains methods for the sampling and testing of aggregates used for concrete, asphalt, sprayed bituminous surfacing, pavements, railway ballast and other engineering purposes. In this section reference is made to those methods relating to the use of aggregate in concrete.

2 TYPES AND USES OF AGGREGATES

Concrete aggregates, regardless of their origin, can be divided into four classes: heavyweight aggregates, normal-weight (or dense) aggregates, lightweight aggregates and ultra-lightweight aggregates. The majority of aggregates used to make concrete fall into normal-weight and lightweight classes.

Normal-weight aggregates are sands (fine aggregate), natural gravels and hard rock, crushed or uncrushed (in the case of natural aggregates). There are also certain manufactured aggregates, such as crushed iron blast-furnace slag, which have a particle density of not less than 2,100 kg/m³. Manufactured aggregates are not a major source of aggregate employed in the production of concrete in Australia and are still required to comply with the requirements of AS 2758.1.

Lightweight aggregates are defined by AS 2758.1 as those having a particle density less than 2,100 kg/m³ but not less than 500 kg/m³. They are used to produce concrete of substantially lower unit mass than that made from dense aggregates and include materials such as scoria, a porous rock of volcanic origin, and manufactured materials such as foamed iron blast- furnace slag and expanded shales.

Structural lightweight concrete, with dry density greater than 1,800 kg/m³ and compressive

strength ranging from 20 MPa to 32 MPa, is produced with scoria, foamed slags and expanded shale. Moderate-strength lightweight concrete falls midway between low-density and structural concretes using normal weight aggregate with respect to unit weight and strength, the most common aggregate used in this type of concrete being pumice. Sintered pulverised fuel ash aggregate is also used but rarely in Australia.

Heavyweight aggregates include limonite, barytes, magnetite and steel ‘punchings’. These are used principally in the production of concrete for shielding against radiation (nuclear power stations and hospital applications) but also find application where extremely heavy mass concrete is required for other reasons

(e.g. to balance floatation in marine structures) but these uses are comparatively rare.

Ultra-lightweight aggregates are defined as those having a particle density of less than 500 kg/m³. They are used to produce concrete with a very low density. Concretes with densities as low as 400 kg/m³ can be produced using materials such as vermiculite (a micaceous mineral) and perlite (a volcanic glass). The thermal insulation values of such concretes are high, but their compressive strengths are very low. They are therefore not suited to structural purposes but rather as an insulating backfill.

Information relating to the categorisation of these aggregates, their uses and impact on concrete density is summarised in **Table 3.1**.

Table 3.1 – Types of Aggregate for Concrete

Weight categories	Types of aggregates	Uses	Indicative concrete density (kg/m ³)
Ultra-lightweight <i>Particle density</i> ^(*) <500 kg/m ³	Vermiculite; Perlite.	Thermal insulation	500 to 1,000
Lightweight <i>Particle density</i> ^(*) <2,100 kg/m ³	Pumice; Sintered pulverised fuel ash.	Lightweight concretes	1,000 to 1,800
	Scoria; Foamed iron blast-furnace slag; Expanded shales; Expanded clays.	Lightweight structural concretes	1,800 to 2,100
Normal-weight <i>Particle density</i> ^(*) ≥2,100 kg/m ³	Natural sands; Natural gravels; Natural rocks; Air-cooled iron blast-furnace slag.	Normal-weight structural concretes	2,100 to 2,800
Heavyweight <i>Particle density</i> ^(*) ≥3,200 kg/m ³	Limonite; Barytes; Magnetite; Steel punchings.	Heavyweight mass concretes; Radiation shielding.	2,800 to 5,000

NOTE: (*) Particle density on dry basis is determined in accordance with AS 1141.5 for fine aggregates and AS 1141.6.1 or AS 1141.6.2 for coarse aggregates.

3 SOURCES OF AGGREGATES

3.1 GENERAL

The common types of normal weight aggregate used in practice are:

- Natural sands and gravels;
- Crushed rock aggregate;
- Manufactured aggregate;

The sources of these aggregates are discussed in the following sections.

3.2 NATURAL SANDS AND GRAVELS

Natural sand and gravel sources are widely distributed throughout Australia although urban development and the past exploitation of the remaining deposits are reducing their availability in locations close to the major cities. Such deposits include:

- **Stream beds** – particles are normally rounded in shape, clean and strong, most of the weak material having been removed by erosion. The particle sizes existing in a specific location will relate to the volumes and speed of water travelling in the stream bed. In most cases this limits stream beds to finer size particles (typically sands);
- **Alluvial deposits** – formed on flood plains and in larger riverbeds. Depending on the original source of the parent rocks as well as the volume and rate of water flow, such deposits may contain rocks and stones of a number of different types and sizes that can be sieved into useful size fractions by screening. Sands from these sources trend towards coarser fractions with particle sizes from 0.4 mm to 5.0 mm;
- **Marine deposits** – formed at the edges and bottom of seas and lakes. Note that marine aggregates may introduce unacceptable quantities of chlorides into concrete unless appropriately managed;
- **Dunes** – formed by the action of wind. These sands tend to be single-sized and very fine (typically sands with predominate particle sizes less than 0.6 mm).

3.3 CRUSHED ROCK AGGREGATE

Crushed rock is sourced from hard-rock quarries in a systematic process of drilling and blasting rock formations to produce suitably sized material to feed into a crushing and screening process. Crushed rock aggregates have the advantage that they can be produced in any desired size and grading by the installation of suitably designed crushing and screening equipment. Rock types that are suitable as concrete aggregates are grouped into three major classifications according to their geological origin:

Igneous Rocks – Igneous rocks are formed from molten minerals emanating from below the earth's surface. Basalt, diorite and granite are examples of igneous rocks commonly used as concrete aggregates. This rock type suitability for concrete aggregate depends on its mineral composition. Some igneous rocks can be unsatisfactory for use in concrete. For example, 'green basalts' contain secondary clay minerals that cause the aggregate to exhibit large volumetric expansion/contraction with changes in moisture content. If this material is used in concrete subject to wetting and drying, it can expand and either adversely affect the durability of or eventually disrupt the concrete.

Sedimentary Rocks – Sedimentary rocks are formed at the earth's surface by the accumulation and consolidation of the products of weathering and erosion of geologically older rocks and minerals. The sediments usually harden by cementation or compaction over very long periods of time. Limestone, sandstone, shales and chert are examples of sedimentary rocks.

Limestones are probably the most widely used as concrete aggregates in this group. Limestones vary from very hard fine-grained crystalline rocks to very soft and weak materials like chalk. Hard limestone is generally suitable for use in concrete, but soft limestone should be avoided.

Sandstones may be suitable as concrete aggregates if they are composed of quartz grains cemented together with amorphous silica. Sandstones that consist of sand grains

bound together by clay are generally unsatisfactory because they are weak and porous and may soften in water.

Shales are generally unsatisfactory because of their soft and absorptive nature. Cherts are hard and dense but, depending on the silica minerals present, may be subject to severe alkali-reactivity in concrete.

Metamorphic Rocks – Metamorphic rocks are formed from pre-existing rocks (both igneous and sedimentary in origin). Actions of changes in the earth's crust including heat and/or pressure lead to change or 'metamorphism' to the original rock. They are dense but may be weak in one plain. Marble, quartzite, Gneiss, phyllite and slate are examples of this type of rock.

The mineral compositions of metamorphic rocks are highly variable, depending in part on the degree of metamorphism and in part on the composition of the parent material. Certain metamorphic rocks may be more prone to alkali-reactivity in concrete as a result of straining of the quartz structure during metamorphism.

3.4 MANUFACTURED AGGREGATE

Manufactured aggregates may be either by-products of an industrial process, such as blast-furnace slag, or products specially manufactured as aggregates (e.g. expanded clays and shales). Expanded clay or shale is now rare in Australia but they were an important source of lightweight aggregate in past years.

Iron Blast-furnace Slag – Iron Blast-furnace Slag is the non-metallic by-product produced in an iron blast furnace (see Part II, Section 2 of this Guide). It consists, essentially, of silicates and calcium alumina-silicates and other bases. By changing the cooling conditions and cooling rates, the molten slag can be made to solidify into a number of different forms with distinctive physical properties. By far the most common slags are those derived from iron blast furnaces, but copper slag has also been used as a concrete aggregate in Australia. Slag aggregates need to undergo a period of weathering in a stockpile before they are used

in concrete. Three types of iron blast furnace slag are available commercially:

- Air-cooled slag is a crystalline product produced by allowing the molten slag to cool slowly in pits or bays under atmospheric conditions. This is the usual source of slag aggregates;
- Granulated slag is a glassy, granular product formed when molten slag is quenched rapidly in water. It is sometimes used as a fine aggregate, but is more often ground to provide a material with cementitious properties;
- Foamed slag is the vesicular product formed by the controlled quenching of thin layers of molten slag in shallow pits. Water may or may not be used for quenching.

Granulated and foamed slags are also sources of lightweight aggregate.

Expanded Clays and Shales – When certain types of clay and shale are heated to about 1,200°C, they begin to fuse and melt. At the same time, the gases generated expand the mass rapidly to form a honeycomb of small cells. The resultant material, when cooled, has a low particle density and unit weight (bulk density), but is hard and strong.

Sintered Pulverised Fuel Ash – Fly ash is a material formed during the combustion of pulverised coal in power station steam boilers or similar high-temperature combustion chambers (Part II, Section 2 of this Guide). A lightweight aggregate is formed by mixing fly ash with water and coal slurry, then pelletising and sintering the mixture to 1,400°C. This form of lightweight aggregate is more common in the UK, USA and Europe but rarely imported to Australia.

4 AGGREGATE PROPERTIES IN AS 2758.1

4.1 GENERAL

Aggregate properties that affect the resulting concrete, and the limits placed on those properties in AS 2758.1, are discussed in Clauses 4.2 to 4.6 below and summarised in **Tables 3.6, 3.7, 3.8 and 3.9** at the end of this section. Note that (as shown in **Table 3.8**) for the durability properties of coarse aggregates covered in AS 2758.1 clauses 9.3.2 to 9.3.4, only one of the three sets of tests is required to be satisfied.

4.2 GRADING

A concept used to describe any aggregate used in concrete is the 'Nominal size' or maximum size of that aggregate. The maximum nominal size of aggregate used in a concrete mix can influence mix binder content, water demand and ease of compaction of the concrete. Aggregates of standard nominal sizes (coarse and fine aggregates) are noted in AS 2758.1 and include details of their recommended specifications including the grading requirements of each nominal size.

Grading is the distribution of particle sizes in a particular nominal size of an aggregate. It influences the water demand of concrete and its subsequent tendency to bleed and segregate. Hence, it influences the mix proportions for a desired workability and water/cement ratio. The coarser the grading (i.e. the lower the proportion of fine aggregate), the lower the cement content required for a given workability and water/cement ratio. However, this is true within limits only as a sufficient amount of fine material is always required to obtain a cohesive mix that can be transported, placed and compacted without segregation.

Aggregates having a continuous, relatively smooth grading curve will generally produce mixtures with fewer large voids between particles. The amount of cement paste required to fill these voids is thereby reduced. In other words, a larger volume of concrete can be made from a given amount of cement paste, and it is, therefore, a more economical mix.

If an aggregate grading is deficient in fines, (i.e. there is not enough sand to fill the voids between coarse aggregate particles), or if the sand is coarse, the concrete mix will be harsh, difficult to place and finish, and will tend to bleed excessively. On the other hand, aggregate combinations with excessive amounts of sand, or excessively fine sands, may produce uneconomical concretes because of the larger surface area of the finer particles. In consequence, an excessive amount of cement may be required to produce the required strength and workability.

Whilst continuously graded coarse and fine aggregates are normally specified for use in concrete, gap-graded mix design combinations (as required, for example, for exposed-aggregate concrete) can also be used to produce satisfactory mixes. **Figure 3.1** shows typical grading curves for continuous and gap-graded aggregate blends.

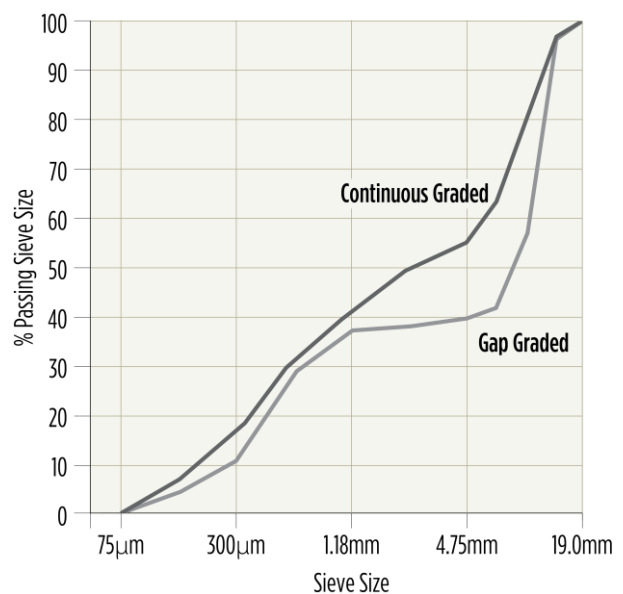

Figure 3.1 – Grading Curves for 20 mm Maximum Size Aggregate Concrete Blend – examples only

While there is a need for aggregates to meet specified grading curves, no ideal grading exists. Good concrete can be produced from blending a range of fine and coarse aggregate gradings and relatively wide ranges of recommended target grading are recommended by AS 2758.1 Appendix B. Some of these recommended ranges in target grading are shown in **Table 3.2** and **Table 3.3**.

The aggregate grading significantly influences the water demand and workability of the concrete, and hence affects concreting operations on the job. Ultimately, it may affect the strength and other properties of the hardened concrete. Hence, it is extremely important that either aggregate gradings be uniform during the currency of a project or that the concrete mix be adjusted when changes occur in the grading.

Even when not necessary for visual reasons (e.g. for exposed aggregate 'architectural' concrete), it is often more economical to maintain uniformity in the aggregates than to adjust the mix proportions for variations in grading. Therefore, limits on variation from the agreed target grading of the submitted sample in the one job are recommended in AS 2758.1. Some of these limits are shown in **Tables 3.4** and **3.5** but others are available in AS 2758.1 including proposed single size aggregate grading as well as other size fractions.

The grading is determined by sieve analysis in accordance with AS 1141.11. In carrying out the sieve analysis, the percentage passing each sieve is determined. The coarse and fine aggregates are sieved separately, each nominal material size, e.g. 20 mm, has its own grading and is usually reported separately.

Table 3.2 – Recommended Grading Limits for Fine Aggregate

Sieve size	Mass of sample passing sieve (%)	
	Uncrushed fine aggregate	Crushed fine aggregate
9.50 mm	100	100
4.75 mm	90-100	90-100
2.36 mm	60-100	60-100
1.18 mm	30-100	30-100
600 µm	15-100	15-80
300 µm	5-50	5-40
150 µm	0-20	0-25
75 µm	0-5	0-20

Table 3.3 – Recommended Grading Limits for Nominal Size, Graded Coarse Aggregate

Sieve size	Mass of sample passing (%) – nominal size of graded aggregate			
	40 mm	28 mm	20 mm	14/7 mm
75.0 mm	100	-	-	-
37.5 mm	85-100	100	-	-
26.5 mm	-	85-100	100	-
19.0 mm	30-70	-	85-100	100
13.2 mm	-	25-60	-	85-100
9.5 mm	10-35	-	25-55	-
6.7 mm	-	-	-	25-55
4.75 mm	0-5	0-10	0-10	-
2.36 mm	-	0.5	0.5	0-10
75 µm	0-2	0-2	0-2	0-2

Table 3.4 – AS 2758.1 Uniformity Requirements for Fine Aggregate

Sieve size	Maximum deviation (%)	
	Uncrushed fine aggregate	Crushed fine aggregate
9.50 mm	-	-
4.75 mm	±5	±5
2.36 mm	±5	±10
1.18 mm	±10	±15
600 µm	±15	±15
300 µm	±10	±10
150 µm	±5	±5
75 µm	-	±5

Table 3.5 – AS 2758.1 Uniformity Requirements for Graded Coarse Aggregate

Sieve size	Maximum deviation (%) – nominal size of graded aggregate			
	40 mm	28 mm	20 mm	14 mm
75.0 mm	-	-	-	-
37.5 mm	±10	-	-	-
26.5 mm	±15	±10	-	-
19.0 mm	±15	±15	±10	-
13.2 mm	±10	±15	±15	±10
9.5 mm	±10	±10	±15	±15
6.7 mm	±5	±10	±10	±15
4.75 mm	-	±5	±5	±5
2.36 mm	-	-	-	-
75 µm	-	-	-	-

4.3 PARTICLE SHAPE AND SURFACE TEXTURE

The shape and texture of aggregate particles has an important influence on the workability of freshly mixed concrete, and hence may affect both the water demand and the water/cement ratio (**Figure 3.2**). Smooth, rounded aggregate particles will produce a concrete with a lower water demand than one made from angular crushed aggregates all other things being equal. However, this is seldom the only criterion in the choice of aggregate.

The strength of concrete is affected by the bond between coarse aggregate particles and the cement paste and by the interlocking characteristics of the aggregate. For optimum strength, a rough-textured, cubical-shaped aggregate will generally give higher strength at the same water/cement ratio.

Figure 3.3 provides guidance on the classification of aggregates according to their particle shape and surface texture. Particle shape is described as rounded, irregular, angular, flaky, elongated, or flaky and elongated. These fairly broad descriptions are normally sufficient to categorise aggregate particles visually.

Similarly, surface texture can be classified as glassy, smooth, granular, rough, crystalline or honeycombed.

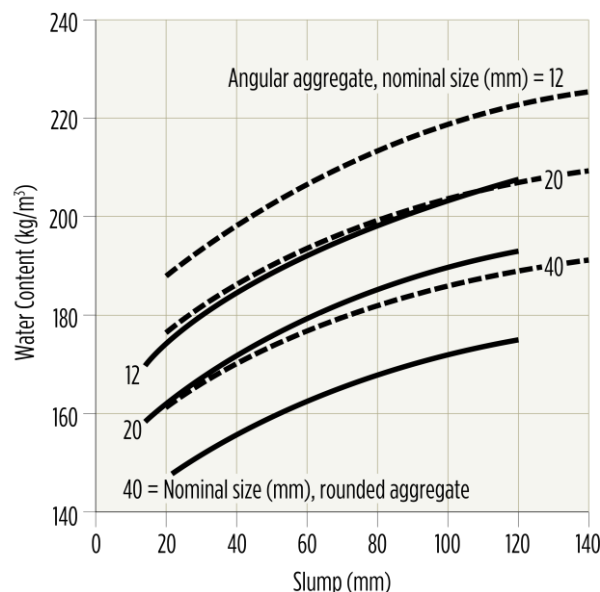

Figure 3.2 – Water Requirement for Concrete using Aggregates of Different Shapes and Nominal Sizes

Because flat, flaky or elongated particles not only reduce workability but may also affect adversely the strength of concrete by their tendency to selective orientation and bridging (thus forming pockets or honeycombs), aggregate specifications generally limit the allowable percentage of such misshapen particles. AS 2758.1 limits the proportion of misshapen particles in the fraction of a coarse aggregate retained on the 9.50 mm test sieve to 10%, when determined in accordance with AS 1141.14 for an aspect ratio of 3:1.

The flakiness index, determined in accordance with AS 1141.15, may also be used to describe the shape of an aggregate particle. This method uses a slotted thickness gauge to determine the percentage, by mass, of flaky particles, where a flaky particle is defined as one with its least dimension (thickness) less than 0.6 of its mean dimension. The mean dimension is defined as the mean of the smallest square sieve size through which the particle passes and the largest sieve on which it is retained. AS 2758.1 limits the proportion of misshapen particles in the fraction of a coarse aggregate retained on the 9.5 mm sieve, assessed by flakiness index, to a maximum of 35%.

The angularity number is another index of the shape of a particle and is determined in accordance with AS 1141.16. It is a measure of relative angularity based on the percentage voids in an aggregate after compaction in a prescribed manner. The most rounded aggregates have about 33% voids. The angularity number is defined as the amount by which the percentage of voids in a compacted aggregate sample exceeds 33%. In practice, it ranges from 0, for a spherical aggregate, to about 12 for very angular aggregates.

4.4 PARTICLE DENSITY AND WATER ABSORPTION

Aggregate water absorption and density are linked through the test methods. The determination of aggregate density and water absorption is carried out in accordance with either AS 1141.5, AS 1141.6.1 or AS 1141.6.2. The bulk density of an aggregate is determined in accordance with AS 1141.4. The principles of these tests are discussed in the following.

Aggregate Density

AS 2578.1 provides three different ways of describing aggregate density:

- *Particle density:* Particle density is defined as the mass of a quantity of aggregate particles divided by their saturated surface-dried volume, i.e. the mass of a solid cubic metre of aggregate. The value is calculated and reported for either aggregate in SSD condition or aggregate in oven dry condition;
- *Bulk density:* Bulk density is defined as the mass of a unit volume of oven-dried aggregate, i.e. the mass per cubic metre of aggregate, as it fills a large container of known volume (including voids between aggregate particles). Bulk density is reported for both loose filled aggregates and for compacted aggregates.

Density is one of the parameters used to classify aggregates. For example, AS 2758.1 defines lightweight aggregates as having a particle density less than 2.1 t/m^3 and a compacted bulk density less than 1.2 t/m^3 .

The density of an aggregate is not a measure of its quality, although density is normally related to porosity which, in turn, is related to strength. The SSD aggregate density is used in proportioning concrete mixes. Substituting one aggregate in a concrete for another of different density will influence the yield and the unit mass of the concrete as well as a number of other properties.

DESIRABLE

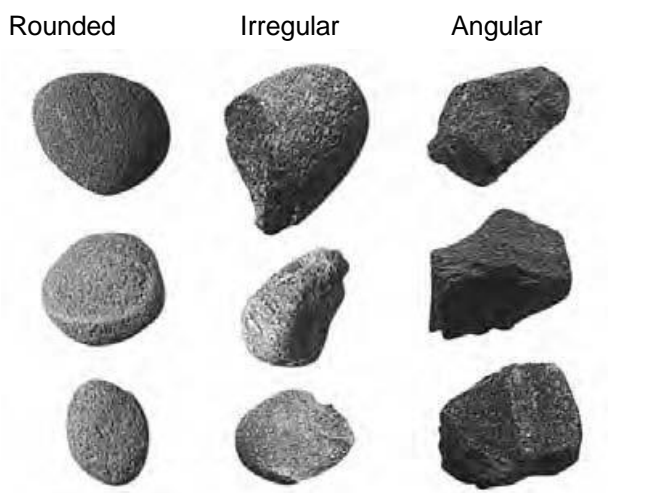

LESS DESIRABLE

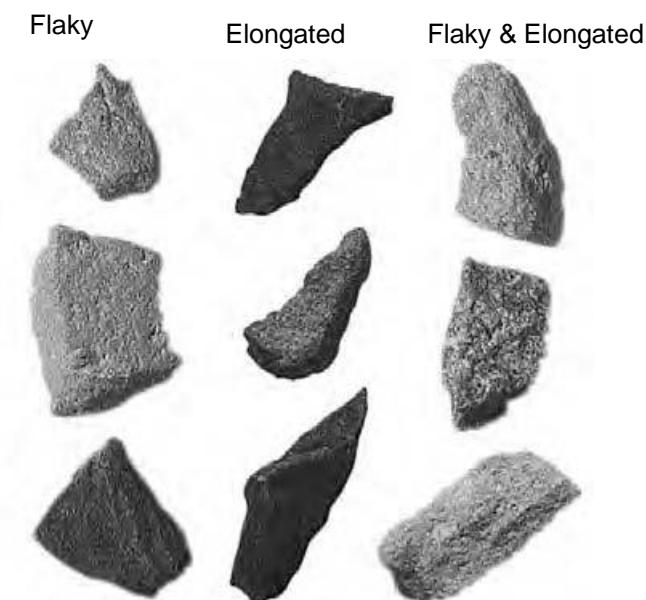

Figure 3.3 – Categorisation of Aggregate Particles by Shape and Surface Texture

Aggregate Water Absorption

All aggregates contain minute pores which can become filled with moisture when saturated. The amount of moisture absorbed in these pores may be quite small, as is the case with dense fine-grained rocks, or quite large, as with lightweight and other porous materials. The amount of moisture absorbed is known as the water absorption of coarse and fine aggregate and may be determined by the methods set out in AS 1141.5, AS 1141.6.1 and AS 1141.6.2.

Surface moisture may also be present in aggregates giving them a damp or wet appearance. The total moisture content of an aggregate is the sum of the absorbed and the surface moisture present.

It is an important parameter because it can affect the amount of water which should be used in a concrete mix to achieve the given water/cement ratio. Variations in the moisture content of stock-piled aggregates are possibly the most common cause of variations in slump and concrete strengths. The surface moisture contents of sands, in particular, are significant.

In preparing a mix design for concrete using a particular aggregate, it is normal to determine first the moisture content of the aggregate in a saturated surface-dry condition (i.e. with the pores filled with water but without free moisture on the surface of the particles). If the aggregates used in the subsequent manufacture of the concrete have moisture contents less than this figure, additional water will need to be added to avoid a loss of workability as the aggregates absorb moisture. If greater than this figure, free moisture will be present on the surface of the aggregates and less water should be added.

4.5 AGGREGATE STRENGTH AND DURABILITY

The strength and physical durability of an aggregate can be assessed using test methods such as the '10% Fines' test better known as 'Wet/Dry Strength Variation' and Los-Angeles Abrasion test. The presence of weak aggregate particles in some aggregates and methods of assessing and limiting these are important to maintaining overall concrete strength and

durability. The principles of these tests are discussed in the following.

Wet/Dry Strength Variation and Wet Strength

Dimensional stability and strength under changing moisture conditions is an important property of aggregates intended for use in concrete. Aggregates that weaken, swell or shrink as they take up or lose water contribute to concrete shrinkage and durability. In extreme cases, the concrete may deteriorate with cycles of wetting and drying because of the expansion and contraction of the aggregate. Dimensional instability occurs in an aggregate when the minerals comprising the rock include unstable clays (e.g. volcanic breccia).

The wet/dry strength variation test set out in AS 1141.22 provides an overall guide as to the dimensional stability of a coarse aggregate. It compares the two crushing forces required to produce fines through breakdown that amount to 10% of a fixed mass of the aggregate being tested. When crushed in the oven-dry and saturated surface-dry conditions the two crushing forces are compared. The result is expressed as the variation in crushing strength as a percentage of the dry crushing strength of the aggregate. The higher the wet/dry strength variation, the less stable is the aggregate.

Clause 9.3.2 in AS 2758.1 sets limits on the maximum wet/dry strength variation between 25% and 45%, depending on the concrete exposure conditions set out in AS 3600 and also provided in AS 2758.1 – Appendix A (also see **Table 3.8** for limits). The high values apply to aggregates to be used in an indoor or protected position and the lower values to aggregates exposed to adverse climatic and service conditions (e.g. cycles of wetting and drying, cycles of freezing and thawing, marine environments, heavy industrial pollution etc.).

The wet strength of an aggregate will influence the strength of concrete made from it. High-strength concrete requires aggregates of high strength. However, weaker aggregates may be satisfactory if the strength of concrete is not expected to exceed that of the aggregate. The strength of aggregates is likely to vary considerably with their structure and mineral composition.

Aggregates influence the drying shrinkage of the concrete by restraining the shrinkage of the cement paste. The rigidity of the aggregate will influence its restraining effect. Thus, the higher the modulus of elasticity of the aggregate, the more effective it will be in reducing the shrinkage of the concrete.

Aggregate strength is generally gauged by the wet/dry variation test in accordance with AS 1141.22 (particularly the wet strength value). Clause 9.3.2 in AS 2758.1 specifies minimum limits for the wet strength of aggregate. The minimum wet strength ranges from 50 kN to 100 kN depending on the concrete exposure condition from AS 3600. The lower value is for aggregates to be used in concrete of lower strengths and used in protected conditions. Higher wet strengths are required for aggregates to be used in more adverse conditions.

Abrasion Resistance

The abrasion resistance of an aggregate is its ability to resist being worn away by friction with other materials. Abrasion resistance is required in an aggregate to avoid degradation during handling, stockpiling and mixing. Breaking down, or grinding of the aggregate during concrete production, generates fines which increase mixing-water demand. This, in turn, may cause some difficulty in producing high-quality concrete.

Except for concrete with an exposed-aggregate finish, the abrasion resistance of the aggregate bears no direct relationship to the abrasion resistance of concrete made from it. The abrasion resistance of concrete is found to be indirectly related to concrete strength.

At the same time, weak, soft, or friable aggregates are obviously unsuitable for concrete exposed to wear, whilst strong abrasion-resistant materials do improve concrete performance in the longer term.

The 'Los Angeles value' test is used to determine an aggregates abrasion resistance and is specified as an option in AS 2758.1. The test method is carried out in accordance with AS 1141.23 and is the most common method of testing the abrasion resistance of coarse aggregate particles. This test combines the

effects of impact and abrasion by tumbling aggregate particles together with steel balls in a slowly revolving steel drum that has 'shelves' causing the aggregate and steel ball mixture to drop from a consistent height during drum rotation. A specified quantity of aggregate is placed in the drum with a charge of standard-size steel balls. The percentage of the aggregate worn away is determined by sieving and weighing. The maximum acceptable percentage loss is set by Clause 9.3.3 in AS 2758.1 for various types of aggregate and for various concrete exposure conditions.

Maximum values are 30%, 35% and 40% depending on the stone type and the exposure classification of the project. The higher the Los Angeles value, the more prone the aggregate to degradation, and the less suitable it is to produce an abrasion resistant concrete.

Unsound and Marginal Stone Content

Aggregate particles that are abnormally weak or low on density or have some other undesirable property must be minimised in a concrete aggregate. The unsound stone content test is covered by AS 1141.30.1. In this test a sample of coarse aggregate retained on a 4.75-mm sieve is soaked in water and then dried. After pressing each particle against the bottom of a dish (using finger pressure) the broken-down particle material passing a 4.75-mm sieve is regarded as unsound. Clause 9.3.4 in AS 2758.1 specifies maximum of 5% by mass for unsound stone content. In addition to this there may be aggregate particles that are not unsound by this measure but are weaker than acceptable to the user of the aggregate. AS 2758.0 Appendix C defines how such 'marginal stone' is assessed and limits defined into the aggregate supply agreement. AS 2758.1 specifies a combined maximum of 10% for the total of unsound and marginal stone (this assessment method is largely targeted at basic igneous rocks that may contain unacceptable levels of decomposed and weak materials).

4.6 AGGREGATE CHEMICAL RESISTANCE AND DURABILITY

Aggregates that are maintained in a benign environment can appear to be quite sound and durable. Two key tests are specified by AS 2758.1 to determine the durability of aggregate in environments where the presence of moisture and chemicals in concrete or from the environment surrounding the concrete may lead to degradation of the aggregate and so the concrete containing this aggregate.

Sulfate Soundness

The soundness of an aggregate is its ability to withstand the aggressive actions to which concrete containing it might be exposed, particularly those due to weather and chemical attack.

If aggregate from a particular source has given satisfactory service in the past, it may be considered sound. The soundness of aggregates not having a service record can be assessed by tests as discussed below.

The sodium sulfate soundness test (AS 1141.24) determines the resistance of the aggregate to disintegration when subjected to a number of cycles of immersion in a sodium sulfate solution, of specified concentration, followed by oven drying. The higher the percentage loss of parent material suffered by the sample, the less sound is the aggregate. Clause 9.3.3 in AS 2758.1 relates the maximum percentage loss to the exposure conditions of the concrete. The limits set maximum values of loss in a range from 6% to 12%, the higher figure being for use in concrete in a protected environment and the lower for concrete in severe exposure conditions.

Fine Aggregate Degradation Factor

The degradation factor is an alternative durability test used to assess the fine aggregate portion of an aggregate blend or sand. It is better suited to evaluate manufactured sand.

The degradation factor test determines the clay and fine silts generated by vigorously agitating clean aggregate in the presence of water. A sample of washed fine aggregate is sized to form a combined test sample of 50 g each of four size fractions between 4.75 mm and 425 µm. The combined sample is agitated in

water in a Sand Equivalent Test cylinder using the power-operated shaking. The agitation is continued for 20 minutes. Following the attrition by agitation of the aggregate particles, the water, carrying the attrition products, is recovered and the aggregate is cleaned with further water. The water sample is transferred to a test cylinder and the clay and silt is treated with a flocculent. The sample is allowed to settle for 20 minutes, the height of the flocculated column is then used in a calculation that reflects the percentage of non-flocculent material (sand) compared to the original material before abrasion in water. The test method is described in AS 1141.25.3 and AS 2758.1 recommends a minimum value of 60%.

Alkali-Aggregate Reactivity (AAR)

Aggregates that are chemically stable will neither react chemically with cement in a harmful manner nor be affected chemically by normal external influences.

Reactive aggregates may result in serious damage to the concrete by causing abnormal expansion, cracking and loss of strength.

Alkali-aggregate reaction (AAR) is the reaction between the alkalis from the cement and other sources and certain mineral phases present in the coarse or fine aggregates. Under certain conditions, deleterious expansion and consequent cracking of the concrete may result (e.g. map cracking) **Figure 3.4**. The two major types of AAR are:

- Alkali-silica reaction (ASR);
- Alkali-carbonate reaction (ACR).



Figure 3.4 – Typical Map Cracking caused by Alkali-Aggregate Reactions

Alkali-carbonate reaction is the reaction between certain dolomitic limestone and alkalis in the pore solution of the concrete. It is rare in Australia.

Alkali-silica reaction is the reaction of the alkalis in the pore solution of the concrete with aggregates containing certain forms of reactive silica such as strained quartz, amorphous silica, opaline material, cryptocrystalline quartz, chalcedony and cristobalite.

A small proportion of concrete throughout the world has suffered from deterioration due to AAR. In Australia, reports of problems in a relatively small, but significant number of structures identified in recent years has increased interest in AAR. A set of national guidelines on minimising the risk of damage due to AAR in concrete structures in Australia (AS HB 79) along with associated changes to AS 2758.1 have been produced to assist designers, specifiers, suppliers and contractors.

Field service records, when available, provide the useful information on the reactivity of aggregates. Apart from the length of time to gather such service records, the information could be either scarce or inconclusive. It is therefore often necessary to use laboratory test procedures to determine the potential reactivity of the aggregates.

With the exception of petrographic analysis (ASTM C 295), previous methods of assessing the likely reactivity of aggregates were considered to be imprecise. The two test methods have been developed into Australian Standards. These test methods are AS 1141.60.1 (Accelerated Mortar Bar Test), and AS 1141.60.2 (Concrete Prism Test).

These test methods take approximately a month for the Accelerated Mortar Bar Test and between a year and two years for the Concrete Prism Test. In view of this, suppliers of aggregates need to build up a number of tests during production of aggregates to be able to provide assurance to a user that the aggregate is suitable for concrete.

Current best practice on how to recognise and mitigate the potential for alkali-silica reactivity

can be obtained from the joint publication of the CCAA and Standards Australia called '*AS HB 79, Alkali-Aggregate Reaction – Guidelines on Minimising the Risk of Damage to Concrete Structures in Australia*'.

The key methods proposed for controlling the risk of ASR in concrete include:

- Use of low alkali cement;
- Limiting the total alkali content of the concrete;
- Using supplementary cementitious materials (e.g. using suitable fly ash, GGBFS and silica fume);
- Preventing moisture ingress to the concrete (to slow reactions and to minimise the introduction of alkalis from salt water) by various means including water repellent sealers;
- Using lithium salts in the concrete mix.

Other Chemical Reactions

Other damaging chemical reactions involving aggregates include oxidation or hydration of certain unstable minerals. Pyrites (ferrous sulfide), for example, can oxidise and hydrate to form brown iron hydroxide which in turn may cause unsightly stains on the surface of concrete. The presence of magnesia (MgO) or lime (CaO) in the aggregate may also cause pop-outs or cracking due to their hydration and expansion.

Impurities and Other Harmful Materials

Besides reactive minerals, aggregates may contain other impurities, such as organic matter, which are harmful to concrete.

Organic matter, such as that derived from decaying vegetation, is capable of delaying setting and hardening of concrete. It is more likely to be found in fine than in coarse aggregate and may be detected by the test set out in AS 1141.34. In this test, sand is placed into a bottle containing a sodium hydroxide solution and allowed to stand for 24 hours. The colour of the liquid above the sample is then compared with the colour of a standard reference solution or standard glass slide. If the colour of the liquid is lighter than that of the reference solution or slide, the amount of organic impurities present in the aggregate is not significant. If the colour of the liquid is darker

than that of the reference solution, the aggregate contains organic compounds and further tests should be made to determine if these are harmful. Normally, the strength, setting time and air content of concrete made with the sand are used as a gauge of the harmful effects of the impurities.

Sugar has a strong retarding effect on the setting and hardening of concrete. In severe cases of contamination, the resulting concrete may not set or may fail to gain appreciable strength. AS 2758.1 specifies a negative result on the presence of sugar in aggregate when determined in accordance with AS 1141.35.

Silt, clay and dust may form a coating on aggregate particles, resulting in weakened bond between the aggregate and the cement paste. Excessive amounts of these fine materials may also increase the water demand of the concrete, resulting in loss of concrete strength and an increase in its permeability.

The amount of fine material is determined by washing a sample of the aggregate over a 75-micron sieve. AS 1141.11 and AS 1141.12 describe the relevant test procedures. The clay content of fine aggregate is assessed using the proportion of 2-micron material as per AS 1141.13. AS 2758.1 requires that all coarse and fine aggregate have a 2-micron proportion of 1% or less of the total mass of the individual aggregate.

For manufactured fine aggregates, AS 2758.1 requires an assessment of the presence of deleterious fines. This assessment determines a Deleterious Fines Index by multiplying the percentage passing the 75-micron sieve for the sand (determined by the methods in AS 1141.11 and AS 1141.12) with the methylene blue adsorption value (also referred to as 'MBV', determined by the method in AS 1141.66). MBV is a test to determine the 'activity' of clays in the fine aggregate. The multiple of these tests is not to exceed 150, however it is noted that manufactured sands with higher values up to 200 have been successfully used in concrete at lower proportions in the concrete aggregate blend.

Coal, wood and other lightweight materials tend to rise to the surface during vibration of

concrete, especially in pavements and floors, and produce a very poor surface finish. They also cause pop-outs and staining on vertical surfaces. The percentage of light particles can be determined using the test set out in AS 1141.31. AS 2758.1 specifies a maximum limit on light particles of 1% by mass of aggregate (3% for slag aggregate).

Where surface appearance of the concrete is important, the amount of coal, wood and charcoal should preferably be even less than 1%.

Aggregates, particularly those dredged from the sea, or those quenched and washed with sea water, may be contaminated by sea salt which contains a high proportion of chloride ions. The amount of chlorides in concrete is of major concern because of its influence on the corrosion of embedded steel. They also increase shrinkage and reduce the sulfate resistance of concrete. AS 2758.1 clauses 14.3.2 and 14.3.3 and AS 1379 clauses 2.7.2 and 2.7.3 specify (in different ways) maximum chloride and sulfate contents for aggregates and for concrete as produced. Adoption of the limits specified in AS 1379 is recommended for assessing suitable limits for aggregate as these may be under those required by AS 2758.1.

Testing of the chloride content and sulfate content of aggregates is performed using the method in AS 1012.20.1 (acid extraction method) but the chloride content may also be assessed using the water extraction method using AS 1012.20.2. The water solubility method has different limits set in AS 2758.1 but is most applicable where an aggregate has chlorides locked within its mineral components that are not available to impact on the chloride level in concrete's pore solution.

5 OTHER PROPERTIES

5.1 GENERAL

There are other properties of aggregate that may impact on the performance of certain types of concrete, but these are not specified in AS 2758.1. Some of them are discussed in the following sections.

5.2 THERMAL EXPANSION

The coefficient of thermal expansion of aggregates varies from rock type to rock type and even within one type. In general, it increases with increases in the silica content of the aggregate.

The main effect of this property is to cause differential stresses between the aggregate and the cement paste (when the concrete is heated or cooled) that tend to break up the bond between the aggregate and the paste.

Concretes made with different aggregates may therefore perform very differently when subjected to high or low temperatures. When exposed to fire, for example, concrete made with siliceous materials is likely to spall and crack (resulting in loss of strength) to a much greater extent than concrete made with calcareous aggregates, e.g. limestone

Figure 3.5.

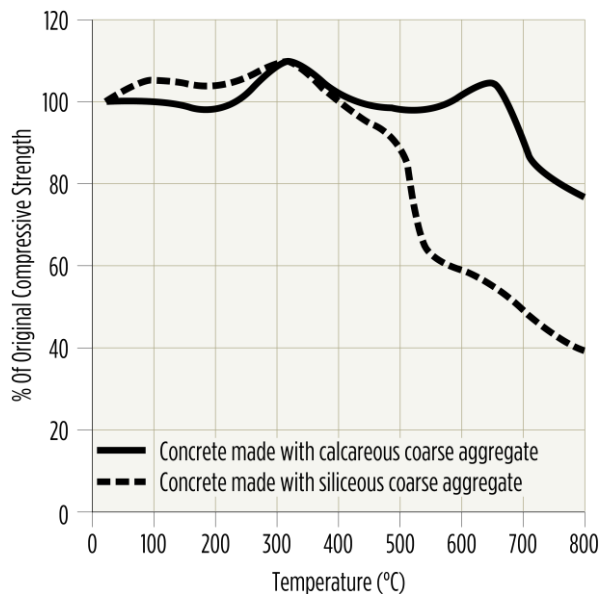

Figure 3.5 – Effect of Coefficient of Expansion of Aggregate on Performance of Concrete in Fire

5.3 COLOUR

The colour of aggregate is an important property in the production of architectural concrete, or that exposed to public scrutiny. There is considerable scope to control concrete colour through the choice of aggregates.

There is a wide variety of colours available in aggregates, ranging from white (e.g. limestone and quartz aggregate) to brown and red (e.g. river gravel) and to very dark coloured aggregates (e.g. basalt, dolerite).

The colour of the fine aggregate normally has the major influence on the colour of the concrete. It is, therefore, important that the supply does not vary during the course of the work and stockpiling of special aggregate may be necessary.

6 SUMMARY OF AGGREGATE SPECIFICATIONS

The specified properties of concrete aggregates and related test methods are best summarised in the Tables on the following pages.

Table 3.6 – Specification of Dimensional Properties of Aggregates

Aggregate Property	Test Methods	AS 2758.1 Specification
Grading	AS 1141.11.1	<p>Fine aggregates:</p> <ul style="list-style-type: none"> – Shall be in accordance with the submitted tender grading (a guide to acceptable target grading is given in Table 3.2); – To vary by not more than permissible deviations given in Table 3.4. <p>Coarse aggregates:</p> <ul style="list-style-type: none"> – Shall be in accordance with the submitted tender grading (a guide to acceptable target grading is given in Table 3.3 with more details in AS 2758.1 Appendix B); – To vary by not more than permissible deviations given in Table 3.5.
	AS 1141.12	<p>All aggregates:</p> <ul style="list-style-type: none"> – The passing 75-micron proportion shall not exceed 2% for coarse aggregates, 5% for natural fine aggregates and 20% for manufactured fine aggregate.
Particle shape and surface texture	AS 1141.14	<p>Unless otherwise specified, the proportion of misshapen particles in the fraction of coarse aggregate retained on a 9.50-mm sieve, using 3:1 ratio, not to exceed 10%.</p>
	AS 1141.15	<p>Flakiness index: not to exceed 35%.</p>

Table 3.7 – Specification of Density and Water Absorption of Aggregates

Aggregate Property	Test Methods	AS 2758.1 Specification
Density	AS 1141.4 AS 1141.5 AS 1141.6.1 AS 1141.6.2	<p>Particle density on a dry basis:</p> <ul style="list-style-type: none"> – For heavyweight aggregate not less than 3.2 t/m³; – For normal weight aggregate, less than 3.2 t/m³ and greater than or equal to 2.1 t/m³; – For lightweight aggregate, less than 2.1 t/m³ and greater than or equal to 0.5 t/m³; – For ultra-lightweight aggregate less than 0.5 t/m³. <p>Bulk density (compacted):</p> <ul style="list-style-type: none"> – For all aggregates other than lightweight, not less than 1.2 t/m³. For lightweight aggregate, less than 1.2 t/m³; – For all coarse lightweight aggregates, the bulk density shall not vary by more than 10% from the tender sample test value.
Water Absorption	AS 1141.5 AS 1141.6.1 AS 1141.6.2	<p>The maximum permissible water absorption should be nominated in the project specification.</p> <p>As a guide (not in AS 2758.1), water absorption figures of normal weight aggregate:</p> <ul style="list-style-type: none"> – ≤5% for an individual fine aggregate; – ≤3% for an individual coarse aggregate; – Water absorption limit of ≤3% for the combined coarse and fine aggregate in a concrete aggregate mixture would be suitable.

Table 3.8 – Specification of Durability Properties of Aggregates

Aggregate Property	Test Methods	AS 2758.1 Specification		
Wet Strength Dimensional Stability	AS 1141.22	Fine aggregates: Satisfactory when conforming to the following conditions.		
		Aggregate type	Concrete exposure classification	Conditions
Abrasion Resistance	AS 1141.23	Uncrushed	A1, A2 and B1	No specific durability requirements.
Soundness	AS 1141.24	Uncrushed	B2 & C (C1 and C2)	Weighted average loss not greater than 6% when tested in accordance with AS 1141.24.
Unsound/Marginal Stone Content	AS 1141.30.1	Crushed	For all exposure classes	Weighted average loss not greater than 6% when tested in accordance with AS 1141.24.
Degradation Factor	AS 1141.25.3			Degradation Factor less than 60 when tested in accordance with AS 1141.25.3.

Coarse aggregates: Satisfactory when conforming to the limits specified for one of the following three sets of tests.

1. Wet strength and wet/dry strength variation

Concrete exposure classification	Minimum wet strength (kN)	Maximum wet/dry strength variation (%)
C (C1 & C2)	100	25
B1, B2	80	35
A1, A2	50	45

2. Los Angeles value and sodium sulfate soundness

Concrete exposure classification	Maximum Los Angeles value (% loss)		Maximum value sodium sulfate soundness (% weighted average loss)
	Coarse-grained rock	All other rock	
C (C1 & C2)	35	30	6
B1, B2	35	30	9
A1, A2	40	35	12

3. Los Angeles value and marginal stone content

Concrete exposure classification	Maximum Los Angeles value (%)		Maximum unsound stone content (% loss)	Total unsound and marginal stone (%)
	Coarse-grained rock	All other rock		
C (C1 & C2)	35	30	5	10
B1, B2	35	30	5	10
A1, A2	40	35	5	10

Table 3.9 – Specification of Deleterious Materials in Aggregates

Aggregate Property	Test Methods	AS 2758.1, AS HB 79 or AS 1379 Specification
Alkali-reactive materials	AS 1141.60.1 AS 1141.60.2 AS HB 79 AS 2758.1 – Appendix C	The supplier shall provide appropriate documentation to allow the assessment of the reactivity classification of the aggregate. AS HB 79 provides details of the classification and appropriate measures of mitigation if required.
Impurities and other harmful materials	AS 1141.34	Colour obtained from test not to be darker than the standard colour of the reference solution.
	AS 1141.35	The aggregate shall test negative to presence of sugar.
	AS 1141.13	Material finer than 2 µm not to exceed 1% for each of the coarse and fine aggregates.
	AS 1141.31	Except for lightweight and ultra-lightweight aggregates – materials, with particle density less than 2.0 t/m ³ , not to exceed 1% by mass in the total of fine and coarse aggregates. For vesicular materials, 3% by mass is permissible.
	AS 1141.32	Weak particles are limited to a maximum of 0.5% by weight in normal weight aggregates and to 2% by weight of coarse lightweight aggregate.
	AS 1379 AS 1012.20.1 AS 1012.20.2	<ul style="list-style-type: none"> – Aggregates tested to AS 1012.20.1 containing sulfide or sulfate salts shall not exceed 0.01% by weight of aggregate. In addition, the combined aggregate used for a concrete mix shall not result in the concrete sulfate content exceeding 5% by mass of Portland Cement; – The combined aggregate tested to AS 1012.20.1 containing chloride salts (expressed as Cl-) exceeding 0.04% should not be used in reinforced concrete and should be reported if exceeding 0.01% (or 0.008% if tested in accordance with AS 1012.20.2). A combination of aggregates and tested to AS 1012.20.1 containing chloride salts which exceed 0.15% should not be used in plain concrete.
Deleterious fines in manufactured fine aggregate	AS 2758.1 – Clause 8.4 AS 1141.11 AS 1141.12 AS 1141.66	<ul style="list-style-type: none"> – Deleterious Fines Index (DFI) is assessed by multiplying the Percentage Passing 75 µm for the aggregate by the Methylene Blue Absorption Value (e.g. 7% passing 75 µm × MBV of 11 = DFI of 77); – DFI must not exceed a value of 150 without further assessment of the sand's performance in concrete.

7 REFERENCES

- 1) AS 3600 – *Concrete structures* (2018)
- 2) AS 1379 – *Specification and supply of concrete* (R2017)
- 3) AS 2758.1 – *Aggregates and rock for engineering purposes – Concrete aggregate* (2014)
- 4) AS HB 79 – *Alkali Reactivity – Guidelines on Minimising the Risk of Damage to Concrete Structures in Australia* (2015)
- 5) AS 1012.20.1 – *Methods of testing concrete – Determination of chloride and sulfate in hardened concrete and aggregates – Nitric acid extraction method* (2016)
- 6) AS 1012.20.2 – *Methods of testing concrete – Determination of water-soluble chloride in aggregates and hardened concrete* (2016)
- 7) AS 1141.4 – *Methods for sampling and testing aggregates – Bulk density of aggregate* (R2013)
- 8) AS 1141.5 – *Methods for sampling and testing aggregates – Particle density and water absorption of fine aggregate* (R2016)
- 9) AS 1141.6.1 – *Methods for sampling and testing aggregates – Particle density and water absorption of coarse aggregate – Weighing in water method* (R2016)
- 10) AS 1141.6.2 – *Methods for sampling and testing aggregates – Particle density and water absorption of coarse aggregate – Pycnometer method* (R2016)
- 11) AS 1141.11.1 – *Methods for sampling and testing aggregates – Particle size distribution – Sieving method* (2009)
- 12) AS 1141.12 – *Methods for sampling and testing aggregates – Materials finer than 75 μ m by washing* (2015)
- 13) AS 1141.13 – *Methods for sampling and testing aggregates – Materials finer than 2 μ m* (R2018)
- 14) AS 1141.14 – *Methods for sampling and testing aggregates – Particle shape, by proportional calliper* (R2018)
- 15) AS 1141.15 – *Methods for sampling and testing aggregates – Flakiness index* (R2018)
- 16) AS 1141.16 – *Methods for sampling and testing aggregates – Angularity number* (R2016)
- 17) AS 1141.22 – *Methods for sampling and testing aggregates – Wet/dry strength variation* (2019)
- 18) AS 1141.23 – *Methods for sampling and testing aggregates – Los Angeles value* (2009)
- 19) AS 1141.24 – *Methods for sampling and testing aggregates – Aggregate soundness – Evaluation by sodium sulfate solution* (2013)
- 20) AS 1141.25.3 – *Methods for sampling and testing aggregates – Degradation factor – Fine aggregate* (R2013)
- 21) AS 1141.30.1 – *Methods for sampling and testing aggregates – Coarse aggregate quality by visual inspection* (2009)
- 22) AS 1141.31 – *Methods for sampling and testing aggregates – Light Particles* (2015)
- 23) AS 1141.32 – *Methods for sampling and testing aggregates – Weak particles (including clay lumps, soft and friable particles) in coarse aggregates* (2008)
- 24) AS 1141.34 – *Methods for sampling and testing aggregates – Organic impurities other than sugar* (2018)
- 25) AS 1141.35 – *Methods for sampling and testing aggregates – Sugar* (2007)
- 26) AS 1141.60.1 – *Methods for sampling and testing aggregates – Potential alkali-silica reactivity – Accelerated mortar bar method* (2014)
- 27) AS 1141.60.2 – *Methods for sampling and testing aggregates – Potential alkali-silica reactivity – Concrete prism method* (2014)
- 28) AS 1141.66 – *Methods for sampling and testing aggregates – Methylene blue adsorption value of fine aggregate and mineral fillers* (2012)

This section discusses the effect of impurities in mixing water on the properties of concrete and then elaborates on the important contributions water makes to concrete performance generally. Water can be taken for granted when considering concrete technology, but this section will attempt to detail some of the important contributions water makes to overall concrete performance.

CONTENTS

1. INTRODUCTION	2
2. CONTAMINENTS	3
2.1 GENERAL.....	3
2.2 SUSPENDED SOLIDS.....	3
2.3 ORGANIC MATTER.....	3
2.4 DISSOLVED SALTS.....	4
3. ACID AND ALKALINE WATER	5
3.1 GENERAL.....	5
3.2 ACIDITY.....	5
3.3 ALKALINITY.....	5
3.4 RECYCLED WATER.....	5
4. THE EFFECT ON CONCRETE DURABILITY	6
5. WATER AND CONCRETE – IMPLICATIONS AND EFFECTS	6
5.1 DENSITY OF WATER.....	6
5.2 COMPLETE CEMENT HYDRATION.....	7
5.3 WATER AND CONCRETE POROSITY.....	7
5.4 WATER AND CONCRETE WORKABILITY.....	7
5.5 WATER AND CONCRETE SHRINKAGE.....	8
6. SUMMARY – WATER IMPURITIES AND CONCRETE	8
7. RELEVANT AUSTRALIAN STANDARDS	9

1. INTRODUCTION

Water is necessary in concrete for two primary reasons:

- To hydrate the cement;
- To provide adequate workability.

Water also plays a role in every aspect of concrete production, placement and service and ultimately concrete performance depends on properties that are due to, or affected by, water.

As discussed elsewhere in this document, water and cement react together chemically to form the paste that binds the aggregate particles together. Concrete sets and hardens through the chemical reaction between cement and water called ‘Hydration’ – which effectively means ‘binding water’.

The water required for this reaction is only part of that necessary to make usable concrete. If only the water required for hydration was used, the concrete would be unworkable and unable to be properly placed and finished. Additional water is required to provide (a) the aqueous environment necessary for the hydration reaction to proceed, and (b) the workability needed for satisfactory concrete placement.

The first part of this module will reiterate the important aspect of ensuring that the quality of the water used in concrete manufacture will not harm the concrete and will elaborate on the various chemical and physical properties that may impact on concrete quality. The second part of this module will discuss ‘water in concrete’ more broadly and emphasise and explain the critical role that water plays in some key aspects of concrete performance.

Most concrete specifications simply require that mixing water shall be potable, i.e. fit for drinking; or that it be clean and free from impurities harmful to concrete. AS 1379 ‘*Specification and supply of concrete*’ requires that mixing water be from a source of acceptable quality, i.e. that:

- Service records of concrete made with that water indicate that it is not injurious to the strength or durability of the concrete nor to the materials embedded in it; or
- The results of tests (in accordance with

AS 1379) are within the limits shown in **Table 4.1** and **Table 4.4**.

Under normal circumstances, water drawn from reticulated town-water supplies will meet these limits and be suitable for making concrete. However, in some parts of Australia, the chloride content of the water may be sufficiently high to require it to be taken into consideration in determining the chloride content of the concrete to ensure that the limits specified in AS 3600 'Concrete structures' are not exceeded.

On projects remote from town-water supplies it may be necessary to utilise water of unknown quality or, on occasions, water which, superficially at least, is unfit to drink because of its turbidity, its smell, its taste, or even its colour. Although such water may be shown by test to be acceptable, there may be impurities present which are potentially harmful to concrete. Some knowledge of their effects will then be required.

2. CONTAMINENTS

2.1 GENERAL

The solids content of water may have two components:

- Solid matter, generally very finely divided, which is carried in suspension; and
- Salts and/or organic matter which are dissolved in the water.

2.2 SUSPENDED SOLIDS

Suspended Solids normally comprise finely divided silts and clays which will settle from the water if it is allowed to stand for a sufficient length of time. Generally, even quite significant amounts of finely divided silt and clay have little effect on the strength or durability of concrete as long as they are evenly distributed throughout the mix. As a rough guide, it may be noted that AS 2758.1 permits up to 1% of material finer than 2 µm (fine silt and/or clay) for each of the coarse and fine aggregates (for more details, see Part II, Section 3 of this Guide). Clays which coat or adhere to the

aggregate particles are always problematic because they interfere with the paste-aggregate bond. On the other hand, evenly distributed in the mixing water, they are much less concerning.

2.3 ORGANIC MATTER

Organic matter can be particularly problematic because it affects strength and, in extreme cases, can prevent the concrete from setting. Even very small amounts of sugar, for example, can have a major retarding effect. (**NOTE:** *Water containing sugar will still be potable. Simply requiring mixing water to be potable may be an insufficient specification*).

More usually, however, organic matter simply retards the rate of strength gain and may be able to be compensated for by allowing additional time for the concrete to gain strength, by increasing the amount of cement in the mix or by the use of admixtures.

Where high levels of organic matter are suspected, there is really no satisfactory alternative to the making of trial mixes with the water in question to ensure its compliance with the limits set out in **Table 4.1**.

Table 4.1 – Limits on Setting Time and Strength of Concrete Made from Water from a Source with no Service Record (determined in accordance with methods specified in AS 1379, after Table 2.1, AS 1379).

Property	Limits
Time of initial set	Within minus 60 minutes and plus 90 minutes of setting time of control sample
Compressive strength:	
- At 7 days	≥90% of strength of control sample at 7 days
- At 28 days	≥90% of strength of control sample at 28 days

2.4 DISSOLVED SALTS

General – The salts commonly found in natural waters generally include the following:

CATIONS	ANIONS
Calcium (Ca ⁺⁺)	Bicarbonate (HCO ₃ ⁻)
Magnesium (Mg ⁺⁺)	Sulfate (SO ₄ ⁼)
Sodium (Na ⁺)	Chloride (Cl ⁻)
Potassium (K ⁺)	Nitrate (NO ₃ ⁻)

Any other salts are normally present in such small amounts as to be negligible in their effects. Of the salts commonly found, by far the most significant are the chlorides and the sulfates.

Chlorides – Chlorides are to be found in naturally occurring waters in arid regions, in brackish water which has been contaminated by seawater and, of course, in seawater itself. They may also be found in some town water supplies because it is derived from a source (e.g. possibly bore water) in which they occur naturally.

The World Health Organisation is reported to permit up to 350 mg/L of chloride in drinking water. A concentration as high as this would be highly unusual in drinking water in Australia. Even smaller levels need to be considered when assessing the total chloride content of the concrete.

Chlorides may affect concrete in two ways. Firstly, when present in relatively large amounts, they may accelerate the setting time of the concrete. While early-age concrete strengths may be improved, later age strengths tend to be less than might otherwise have been achieved. Calcium chloride, in amounts up to 2% by mass of cement, is sometimes used to accelerate the setting time of plain concrete in cold weather. Even seawater, which may contain up to 30,000 mg/L of chlorides, has been used to make satisfactory mass concrete when no other water has been available. (**NOTE:** *High levels of chloride in mixing water will be problematic if there is any embedded steel.*)

The use of calcium chloride as an accelerator is a practice which should generally be avoided. It can be added as a flake material or as a solution. Added as a solid there is a risk that it may not be evenly distributed throughout the

mix and lead to unacceptably high chloride concentrations in parts of the concrete.

Secondly, quite small amounts of chloride may be detrimental to the durability of reinforced concrete.

They act to initiate and accelerate corrosion of the reinforcing steel under certain conditions. In consequence, AS 1379 limits the acid-soluble chloride-ion content of concrete, from all sources, to 0.8 kg/m³ of the concrete.

Sulfates – Sulfates may be present in naturally occurring ground water, in industrial effluents, in sewerage and in marine environments. They can affect concrete by affecting setting times and later-age strengths, and potentially by exacerbating sulfate attack of the concrete. Some sulfate salts react with paste components (e.g. lime) to form an expansive reaction product that may lead to cracking, while others (e.g. magnesium sulfate) may react directly with the paste components and cause them to disintegrate and the concrete to lose its integrity.

The sulfate content of natural waters should be checked to ensure that the total sulfate content of the concrete, from all sources, does not exceed 50 g/kg of cement as specified in AS 1379.

Carbonates and Bicarbonates – Sodium carbonate and sodium bicarbonate, if present in sufficient concentrations can cause set acceleration, even very rapid set, with some cements. Reduced strength may also occur.

Calcium and magnesium carbonates are sufficiently insoluble as to be negligible in their effects. Whilst the bicarbonates are more soluble, it would be highly unusual for them to be present in amounts sufficiently large to cause significant problems except in waters highly charged with carbon dioxide (some mineral waters) where testing of the water would be advisable.

The maximum level of impurities in water for use in concrete has been collated from a variety of texts and Standards and is shown in **Table 4.2** below.

Table 4.2 – Limits on Impurities in Concrete Mixing Water (extracted from various international standards specifying mixing water quality)

Impurity	Maximum Concentration (mg/L)
Total Dissolved Solids (TDS)	2,000
Chloride (as Cl ⁻)	500
Sugar	100
Sulfate (as SO ₄)	1,000
Alkali carbonates and bicarbonates	1,000
Sodium Equivalent (as Na ₂ O Equivalent)	1,500
Oil and Grease	50

The potential effect from a range of impurities that may be present in concrete mixing water is shown in **Table 4.3** below.

Table 4.3 – Possible Effects from Impurities in Mixing Water

Impurity	Possible Effect
Oil, fat or detergents	Air entraining possible
Calcium Chloride / some other calcium salts	Probability of set acceleration
Sugars, salts of zinc, lead and a range of other inorganic and organic materials	Probability of set retardation
Chloride ions	Strong probability of steel corrosion

3. ACID AND ALKALINE WATER

3.1 GENERAL

AS 1379 requires that mixing water have a pH greater than 5. Whilst pH of water is not an entirely satisfactory quality measure, it nevertheless serves to alert the user to the possibility of undesirable impurities being present.

3.2 ACIDITY

Acidity in natural waters is most often caused by dissolved carbon dioxide but may also be caused by industrial wastes or by the oxidation of pyrites or other sulfides. Some mine waters, for example, become highly acidic as a result of the formation of sulfuric acid by this process. Water may also become acidic from decaying vegetable matter resulting in the formation of humic and tannic acids. It is not necessarily the pH of these organic acids that is problematic, but other properties of these compounds may affect concrete performance.

3.3 ALKALINITY

Alkalinity in natural and treated waters may be due to the presence of sodium carbonate, which hydrolyses in solution to form hydroxyl ions, or to the presence of the alkali hydroxides, sodium and potassium. The effect of sodium carbonate on the setting and rate of strength gain of concrete has already been mentioned in 2.4.

The alkali hydroxides are unlikely to be present in sufficient concentration to cause problems since cement itself is a highly alkaline material.

3.4 RECYCLED WATER

It is almost universal practice in many parts of Australia for the pre-mixed concrete industry to recycle the water used to wash out truck mixers and agitators. This is one of the practices undertaken by the industry to minimise the impact of concrete manufacture on the environment. Such water is invariably alkaline and numerous tests have shown the practice to be satisfactory.

AS 1379 permits the practice provided that the water is stored in a manner which prevents it becoming contaminated with materials deleterious to concrete and the water drawn from the storage outlet is of acceptable quality as noted in the Standard.

Specific water quality limits, as noted in AS 1379, are shown in **Table 4.4**.

Table 4.4 – Limits on Impurities in Mixing Water (determined in accordance with methods specified in AS 1379, after Table 2.2, AS 1379)

Impurity	Maximum Concentration
Sugar	100 mg/L
pH	>5.0
Oil and grease	50 mg/L

NOTE: ppm = mg/L

4. THE EFFECT ON CONCRETE DURABILITY

In considering the effect of mixing water on the durability of concrete, it is important to distinguish between short- and long-term effects. It is important also to assess the content of impurities in the mixing water in the light of their content in the other components of the concrete.

It should be noted that mixing water which is satisfactory for plain or mass concrete may be unsuitable for reinforced concrete, and even more unsuitable for prestressed concrete, in relation particularly to its chloride content and the danger of steel corrosion being initiated and/or accelerated. Similarly, the presence of sulfates in the mixing water may have little effect in the short term but be detrimental in the long term if the concrete is exposed to cycles of wetting and drying. The presence of chlorides and sulfates in the mixing water should always be regarded as undesirable and the limits set in AS 1379 should always be applied.

The cumulative effect of some impurities if they are present in some of the other components of the concrete should be noted. For example: AS 1379 limits the total chlorides and the total

sulfates in the concrete from **all sources**. Chlorides or sulfates in the mixing water may be sufficient to cause these limits to be exceeded. Similarly, sodium salts in the mixing water may be sufficiently low as to have little or no effect on the setting time or strength of the concrete but they could be sufficient to influence the development of alkali-aggregate reactions (ACR/ASR, see Part II, Section 3 of this Guide) should the aggregates be potentially reactive.

5. WATER AND CONCRETE – IMPLICATIONS AND EFFECTS

Viewed simply, water quality may impact the setting time and strength performance of concrete, while water quantity may impact workability, strength and durability performance. From the perspectives of concrete production and concrete placement, the effects of water are quite immediate and obvious. However, the role of water is far more fundamental and nuanced.

Several important topics relating to water as a material, the role that it plays in concrete, and how it impacts concrete performance will be discussed below.

5.1 DENSITY OF WATER

W/C ratio is calculated on a mass basis – so for a cubic metre containing 300 kg of cement and 180 L of water (a W/C ratio of 0.6) – it might appear that the water is the minor partner – and by mass it is. However, mass measures do not provide a reasonable reflection of the hydration reaction space.

The interaction of cement and water is better reflected by considering their relative volumes, as this more correctly reflects the surface area available for the hydration reaction to occur. In the above example, in one cubic metre the 300 kg of cement (SG = 3.15) occupies a space of about 95 litres, while the 180 L of water (SG = 1) occupies 180 litres. Volumetrically, the water overwhelms the cement – that is, the cement particles are relatively diluted. In fact, a W/C ratio of 0.32 is necessary before the water (180 L) and cement (560 kg) occupy the same

volumes (i.e. 180 litres) (**Figure 4.1**). As the water reacts with the cement it leaves behind voids (porosity) – so the concrete we think of as ‘solid’ is in fact quite ‘porous’. Water is <10% of the mass of concrete but occupies almost 20% of the volume.

W/C Ratio = 0.6

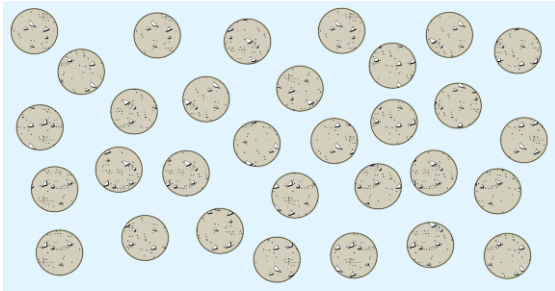

W/C Ratio = 0.32

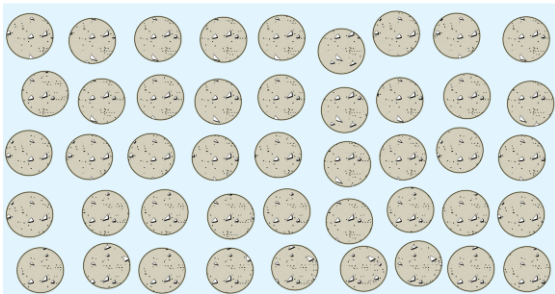

Figure 4.1 – Comparison of Relative Volumes – W/C 0.60 versus W/C 0.32

5.2 COMPLETE CEMENT HYDRATION

It is noted in some texts that 1 kg of cement requires about 250 mL of water to fully hydrate it. This properly reflects the amount of chemically combined water in the Calcium Silicate Hydrates (CSH), but not the environment in which the hydration reaction occurs.

The hydration reaction occurs in an aqueous environment and water is being bound both chemically (to form CSH) and physically (by absorption into pores and adsorption onto the surface of the CSH). The consequence is that about 420-450 grams of water is required to fully react with 1 kg of cement – that is a W/C ratio of 0.42-0.45. So, if only 250 mL of water is added to 1 kg of cement, the maximum degree of cement hydration possible is about $0.25/0.42 = 60\%$.

5.3 WATER AND CONCRETE POROSITY

There are competing issues in relation to the ‘ideal’ W/C ratio. Unless there is sufficient water (W/C ratio >0.42) in the mix, the cement will not be fully hydrated. However, the inter-particle space in concrete – the porosity – has its origin in the initial volume of water in the mix.

In low (say, 0.35) W/C ratio mixes, although the cement will not at any time be fully hydrated, sufficient hydration product can ultimately be produced to fill the void spaces between particles (which are closer together at lower W/C ratios) to provide the strength and durability performance that is required of this ‘high strength’ concrete. While this is not necessarily an efficient mix (in terms of cement utilisation), it is an effective mix (provided the required workability and strength and durability performance levels specified are achieved).

It is also worth noting that, because of the (relative) lack of water at this low W/C ratio, this concrete will ‘self-desiccate’ – that is, dry itself from the inside. (This is due to water that is held in the pores reacting with cement as the hydration reaction proceeds). This then emphasises the need for curing (by adding water) with low W/C ratio concretes – to ensure that capillary porosity is kept full of water to allow the hydration reaction to proceed to its maximum extent.

5.4 WATER AND CONCRETE WORKABILITY

The relationship between water content of a mix and slump is not linear – it is exponential. Once slump is achieved, as more water is added the increase in slump per (say) litre of water added becomes greater.

An initial on-site addition may not greatly increase slump, so more water is added, and then possibly one or more extra additions may occur. Suddenly, the mix turns into what has been described as ‘cream-of-aggregate soup’.

The effectiveness of water additions in increasing slump varies. Mixes with larger maximum aggregate size require less water per cubic metre to achieve a given slump increase.

The effect of water addition on slump also depends on the initial slump value.

To double the slump value, it has been found that the amount of water required for 38 mm top size, 20 mm top size and 10 mm top size mixes is about 11 litres, 13 litres and 17 litres per cubic metre respectively.

5.5 WATER AND CONCRETE SHRINKAGE

A considerable amount of research work has been carried out to assess the quantitative

effect of water on concrete drying shrinkage. A generally accepted estimate of this effect is that drying shrinkage increases by about 5 microstrain per kg of water per cubic metre of concrete.

While water content is by no means the most important determinant of concrete drying shrinkage, it does need to be considered as part of the array of contributors to concrete drying shrinkage performance.

6. SUMMARY – WATER IMPURITIES AND CONCRETE

Component	Comment	Limits specified (AS 1379)
Suspended Solids	Fine solids evenly distributed in the mixing water have little effect.	
Organic matter	Adversely affects strength; Can prevent setting (sugar particularly); Where suspected, trial mixes may be required.	Sugar <100 mg/L Oil and grease <50 mg/L
Dissolved chloride salts	May accelerate setting times and reduce long-term strength; Detrimental to durability when used in reinforced or prestressed concrete.	
Dissolved sulfate salts	Significant effects unusual; Natural water in arid regions requires checking.	
Dissolved carbonates and bicarbonates	Combined sodium carbonate/bicarbonate content of up to 2,000 ppm may be safe but testing advisable when content exceeds 1,000 ppm; Calcium and magnesium carbonates usually negligible in their effects.	
Acidic water	Acidity itself not usually a problem (cement being highly alkaline neutralises the acid) but the materials which caused the acidity may be a problem (e.g. sulfides, decaying vegetable matter, etc).	pH > 5.0
Recycled water	Generally satisfactory; Should comply with limits shown in Table 4.2 .	
Concrete durability	Note different quality requirements for plain (unreinforced) concrete and reinforced/prestressed concrete. Cumulative limits if some impurities are present in other components of the concrete. Note the cumulative limits placed upon chlorides and sulfates particularly.	<u>Chlorides:</u> – 0.8 kg/m ³ or specified limit – with embedded steel; – 2.0 kg/m ³ or specified limit – no embedded steel. <u>Sulfates (as SO₃):</u> 50 g/kg cement in hardened concrete

7. RELEVANT AUSTRALIAN STANDARDS

- 1) AS 1379 – *The specification and supply of concrete*
- 2) AS 2758 – *Aggregates and rock for engineering purposes*
- 3) AS 2758.1 – *Concrete aggregates*
- 4) AS 3600 – *Concrete structures*

This section provides general information on admixtures used to modify the properties of concrete – in both the plastic and hardened states. Comment is included on their purpose and effects, including the influence of the other constituents of the concrete. In addition, it provides some general guidance on the use of admixtures.

CONTENTS

1 INTRODUCTION	2
2 TYPES OF ADMIXTURES	3
2.1 CLASSIFICATIONS AND MECHANISMS.....	3
2.2 AIR-ENTRAINING ADMIXTURES (AEA).....	4
2.3 SET CONTROLLING ADMIXTURES.	5
2.4 WATER REDUCING ADMIXTURES .	7
2.5 OTHER ADMIXTURES	12
3 GUIDANCE ON THE USE OF ADMIXTURES	17
4 AUSTRALIAN STANDARDS AS 1478 – PARTS 1 AND 2	18
5 CHOOSING AN ADMIXTURE	18
6 ADMIXTURE DOSE	19
7 SUMMARY – ADMIXTURES FOR CONCRETE	20
8 RELEVANT AUSTRALIAN STANDARDS	22

1 INTRODUCTION

Many materials have been used over the centuries to modify the properties of ancient and modern binders and concrete mixes. The Roman's use of blood as an admixture was an early (and effective) means of producing air entrainment. The Romans also used lard and milk for this purpose.

The increased use of modern chemical admixtures was closely aligned with the growth in ready mixed concrete production that occurred in the middle of the 20th Century.

While early admixture use was primarily in the USA, Australia was quick to realise the advantages offered to the construction industry, and by about 1970 the prevalence of admixture

use in Australia was probably the highest in the world. Britain and Europe were somewhat slower to adopt this approach and ultimate acceptance was probably linked to Australian involvement in promoting the use of ready-mixed concrete as an alternative to site-mixed concrete.

The introduction of modern dispensing equipment provided a major advance in gaining consistent concrete properties when using chemical admixtures.

Until the mid-1960's, the only recognised standard for the use of chemical admixtures was that issued by the ASTM. Work on an Australian Standard commenced around 1965 with the first Australian Standard being published in 1969.

The Australian Standard (AS 1478.1) defines an admixture as *'a material, other than water, aggregate and cementitious materials, used as an ingredient of concrete, and added to the batch in controlled amounts immediately before or during its mixing to produce some desired modification to the properties of the concrete'*.

In general terms, concrete admixture use involves using relatively small quantities of (powerful) chemicals which must be used in controlled doses. Their actions can be quite complex, and one admixture may impact on the performance of another in a concrete mix. It is always advisable to (a) check history of using particular admixture combinations, or (b) test the proposed combination in a trial mix before embarking on concrete production on a large scale. Admixture suppliers are generally able to provide historical usage information.

Some admixtures have a specific role and only affect one property (e.g. water reduction) but many admixtures affect more than one property of the concrete. Most work with the other materials in the concrete, including the cement and SCM's, to determine their ultimate effect. Their effectiveness is usually temperature

dependent, generally improving with increasing temperature and slowing down as temperatures fall. This potential for multiple effects emphasises the need to carry out trial mixing with all concrete mix components to fully assess admixture effectiveness.

2 TYPES OF ADMIXTURES

2.1 CLASSIFICATIONS AND MECHANISMS

Chemical admixtures for concrete can be classified in general terms as General Use and Special Purpose Admixtures. The former group is used in most concrete, while the latter provide specific performance characteristics such as providing anti-washout, hydration control and corrosion inhibiting actions.

Table 5.1 describes the types of admixtures available for both General Use and Special Purpose applications, and the **Summary** table (pages 20-21) describes their application and general effects on concrete performance.

There are several mechanisms that are fundamental and form the basis of (most) admixture use:

- Dispersion of cement in the aqueous phase of concrete;
- Alteration of the rate of cement hydration – particularly of the C₃S mineral;
- Reaction with by-products from hydration e.g. alkalis and free lime;
- Pore filling.

Table 5.1 – Types of Admixtures

Air entraining	(Type AEA)
Set-controlling	Set-accelerating (Type Ac); Set-retarding (Type Re).
Water-reducing	Normal (Type WR); Medium-range water-reducing – Superplasticisers (Type MWR); High-range water-reducing – Superplasticisers (Type HWR).
Water-reducing/ set-controlling	Water-reducing/ set-accelerating (Type WRAc); Water-reducing/set-retarding (Type WRRe); High-range water-reducing/set-retarding – superplasticisers (Type HWRR).
Thickening agents	'Pumpability' aids
Shrinkage-reducing/ shrinkage-compensating	
Permeability reducing	
Special purpose	Special purpose/normal setting (Type SN); Special purpose/accelerating (Type SAc); Special purpose/retarding (Type SRe).

2.2 AIR-ENTRAINING ADMIXTURES (AEA)

Air entrainment is different to air entrapment. Air will be entrapped in the plastic concrete during mixing; and should be removed by compaction during placing. It is uncontrolled – and can create large voids in the hardened concrete which is very detrimental to concrete performance. It is critical that this entrapped air be removed during the compaction of concrete.

Air entrainment is purposefully entrained air comprising very small-sized bubbles that are evenly distributed through the concrete paste and which remain (quite) stable during handling and compaction. These finely dispersed air bubbles have a minor impact on strength that can be compensated for in mix design. The air bubbles are spherical and may vary in size from 10 microns to 1 mm (Figure 5.1).

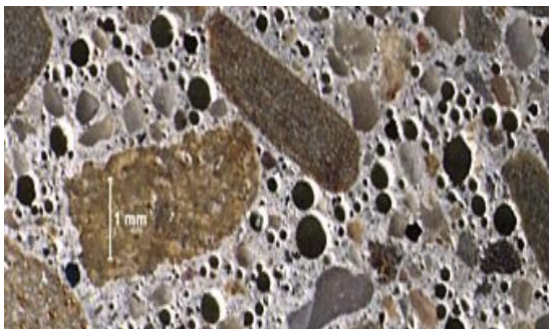

Figure 5.1 – Air Entrained in Concrete Paste

Air entrainment was developed primarily to improve the resistance of concrete to destructive cycles of freezing and thawing (Figure 5.2). Freeze-thaw protection is of major importance in any region where snow and ice are common weather features. It is therefore almost mandatory in much of the northern hemisphere.



Figure 5.2 – Pavement Damage due to Freeze Thaw Cycles

There are only a few regions in Australia where such protection is needed. These include any areas where there are repeatedly low overnight temperatures capable of causing freezing of the water in concrete.

The use of air entrainment has extended beyond its primary purpose and it is also used to enhance plastic performance in concrete mixes with (a) a low cementitious content, and (b) where workability of mixes is compromised by poor sand grading(s). Higher air contents will increase the cohesiveness of concrete mixes and can also lead to a reduction in bleed volume and rate.

Benefits of Air Entrainment

- Protection against freeze-thaw damage;
- Cohesiveness improved = less segregation;
- Control of bleed;
- Improved workability – enables a reduction in water content and therefore a decreased W/C ratio;
- Improved durability in cold climates.

Negative Aspects of Air Entrainment

Increasing air content reduces strength. This effect can be offset by changing mix proportions and is assisted by the reduction in the W/C ratio that may occur.

Regardless of the form it takes, a 1% increase in air content in the concrete can reduce the compressive strength by about 5%. In favourable conditions, the water reduction obtained from air entrainment can be sufficient to offset the strength loss.

AS 1478.1 indicates that the compressive strength of concrete with air entrainment should not be less than 90% of the compressive strength of the concrete without the admixture.

Air entrainment in Normal Class concrete not subject to freeze-thaw conditions is typically 2-4% but is increased to 5-6% for freeze-thaw conditions. The reduction in compressive strength and the durability benefit are shown in Figure 5.3.

Air entrainment at levels in the order of 5% is also used for low slump concretes (20-40 mm slump) that are supplied to paving machines for

concrete road construction and for other slip-forming applications.

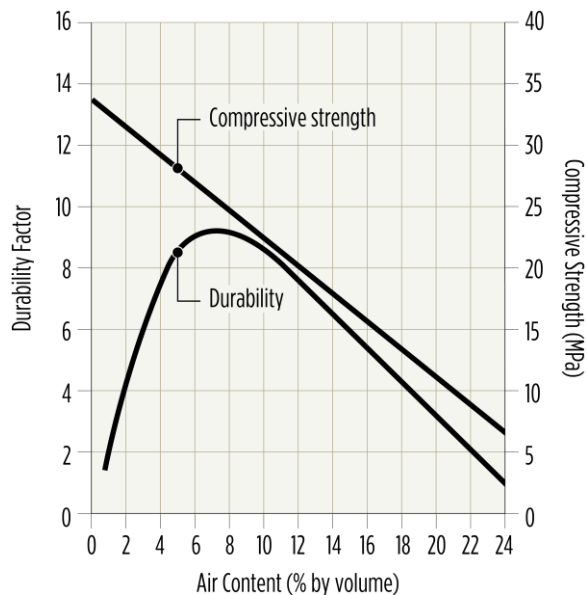

Figure 5.3– Effect of Air Entrainment on Compressive Strength and Durability

Materials

Air-Entraining Agents (AEA's) are derivatives of:

- Salts of wood resins;
- Sulfated or sulfonated petroleum hydrocarbons;
- Salts of petroleum acids;
- Fatty and resinous acids and their salts.

Air-Entraining Action

Air entrainment creates a void system with a large number of minute air bubbles dispersed evenly through the concrete paste. The size and spacing of the bubbles are very important.

The air-entraining action is affected by:

- Type and concentration of admixture;
- Type and composition of cement:
 - Increasing alkali increases air content but improves the stability of the entrained air;
 - Increases in cement fineness tend to reduce the air content.
- Cement content:
 - Effect is greater with lower cement contents.
- Use of SCM:

- May require higher dose for particular air content – particularly with some (high LOI) fly ashes.
- Mix proportions;
- Grading of fine aggregate – increase in fine sand may reduce air content:
 - It may be possible to reduce sand by 1% for every 1% of air while water may be reduced from about 4% for rich mixes to about 15% for lower grade mixes.
- Type and condition of mixing equipment;
- Presence of other admixtures:
 - Admixture interactions may increase air entrainment.
- Temperature of the concrete as mixed:
 - Lower temperature permits more air entrainment.

2.3 SET CONTROLLING ADMIXTURES

'Set controlling' refers to those admixtures that either accelerate or retard the setting and hardening of concrete.

Accelerators (Type Ac)

Accelerators are used to reduce the setting time of a concrete mix and/or accelerate the strength gain of concrete. Some will do both tasks while others will predominantly perform one of the tasks. This is accomplished by accelerating the initial rate of the hydration reaction between the cement and the water.

In the plastic state, accelerators affect both the initial and final set of the concrete providing positive benefits relating to finishing time, particularly in colder weather. Total bleed may also be reduced due to the faster setting time.

In the hardened state accelerators may increase the strength at early ages but may reduce the long-term strength of concrete. Their use can also impact on drying shrinkage and creep and generally results in increases in both properties. Heat of hydration development will typically increase due to the accelerated hydration reaction.

History

Historically, calcium chloride was used as an accelerator as its use results in a significant

reduction in setting time as well as increased early strength development.

However, due to its chloride content, calcium chloride has an adverse effect on the durability of the concrete through the promotion of corrosion of any embedded reinforcement. Calcium chloride may also have negative effects on concrete durability by enhancing the degree of attack where (a) the concrete is exposed to high levels of sulfates, and (b) where ASR is being experienced.

Non chloride-based accelerators are now available and are widely used. They have similar effects on setting time and strength development, but without increasing the risk of corrosion of embedded reinforcement.

Compounds which have been used as accelerators include calcium formate, calcium nitrate, calcium nitrite and thiocyanate salts.

AS 3600 'Concrete structures' and AS 1379 'Specification and supply of concrete' impose limits on total chlorides in concrete which effectively prohibits the use of calcium chloride in reinforced and prestressed concrete. Calcium chloride can be used in concrete that does not contain any embedded material (including reinforcing steel) that requires protection from corrosion.

Benefits of Accelerators

- Faster setting; and/or
- More rapid strength gain.

Negative Aspects of Accelerators

- Possible lower long-term strengths;
- Increased shrinkage and creep.

Materials

Accelerators can be derived from inorganic or organic materials.

Inorganic

- Sodium silicates;
- Aluminates;
- Calcium chloride;
- Calcium nitrate.

Organic

- Triethanolamine;
- Calcium formate.

The degree of set acceleration depends on:

- Type and concentration of accelerator;
- Temperature of concrete;
- Type of cement;
- Use of SCM;
- Cementitious content.

In specialised concrete applications like shotcrete, high performing accelerators are used to cause concrete to set almost immediately it makes contact with the substrate it is being placed on (typically the roof or walls of a mine shaft). These shotcrete mixes are often 'put to sleep' to maximise the plastic stage to allow transport of the concrete to the job site. When the plastic concrete is sprayed onto the mine roof or wall a highly effective accelerator is added to the concrete at the spray nozzle. The effectiveness of these accelerators is such that the concrete almost immediately sets upon contact with the substrate. Typical of these accelerators are silicate and aluminate compounds.

Retarders (Type Re)

Retarders are designed to slow down the rate of setting of concrete which can provide advantages in certain situations. Retardation is accomplished by slowing down the rate of reaction between the cement and the water in the first few hours. Retarders have minor impacts on strength development. Retarders are used as follows:

In hot weather:

- To ensure concrete remains placeable after long hauls;
- To provide adequate time for compaction and finishing.

In large pours:

- To maintain a live face for concrete placement in mass concrete and large pours to avoid the creation of cold joints.

Benefits of Using Retarders

- Slows down setting time;
- Negligible impact on strength after 1 day;
- Maintains workability in hot conditions.

Negative Aspects of Retarders

- Strengths up to 1 day may be reduced slightly;
- Additional time prior to concrete setting. (For highly workable mixes this may increase the risk of plastic settlement cracking. In high evaporation environments this may increase the risk of plastic shrinkage cracking.)

Materials Used

- Sugars and carbohydrates;
- Soluble borates and phosphates;
- Hydroxy-carboxylic acids.

Retarders operate by attaching themselves to the hydrating cement particles and slowing the rate of hydration and hence slowing the progress towards setting (**Figure 5.4**).

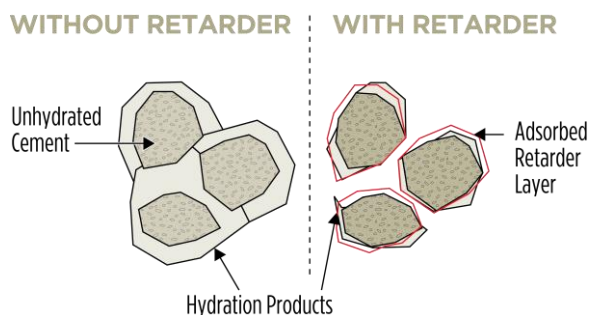

Figure 5.4 – Retarder Action on Hydrating Cement Particles

The degree of retardation is affected by:

- Type and concentration of admixture;
- Temperature of concrete;
- Chemical composition of cement:
 - Cement fineness, alkali content, C_3A and gypsum content all affect the reactivity;
 - Higher cement surface area requires greater dose for same effect;
 - Higher alkali and higher C_3A contents require greater dose for same effect.
- Cementitious content;
- SCM;
- Time of addition to mix:
 - Delaying addition until after water has been added to cement will give longer, more effective retardation.

2.4 WATER REDUCING ADMIXTURES

Water reducing admixtures are generally described as being either Normal Range, Mid-Range or High Range. As the names imply, these admixtures provide water reduction to various degrees, and without any detrimental effect on other concrete properties. The ability of certain chemicals to provide water reduction was first recognised in the early 1930's.

Normal-Range Water Reducers (Type WR)

Effects

Water reducers can be used in three main ways:

- To increase workability or slump without other changes and hence maintain the same strength;
- To maintain the workability (or slump) and cement content with less water and produce increased strength;
- To reduce the cement content and the water content whilst maintaining the workability, slump and strength, hence providing greater economy.

For most normal range water (Type WR) reducers, the level of water reduction is of the order of 4-10%.

Action of Water Reducers

These admixtures disperse cement particles that otherwise tend to clump together. This is achieved by applying the same electrical charge to all cement particle surfaces – which causes the particles to repel one another. Water trapped between the cement grains becomes available to the mix which improves the workability of the mix. As well as increasing the fluidity of the cement paste (and the concrete), it also provides a larger available cement surface area for hydration to occur (**Figure 5.5**).

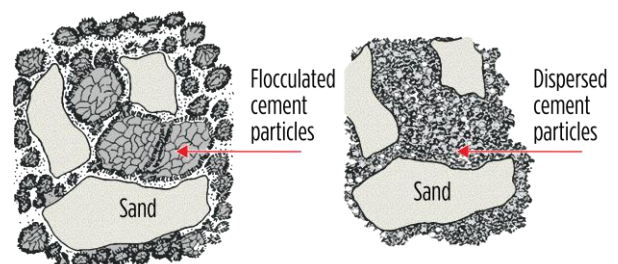

Figure 5.5 – (a) Flocculated Cement Particles and (b) Dispersed Cement Particles

Benefits of Using Water Reducers

- Same workability with less water;
- Better slump control;
- Improved pumpability;
- Greater cohesiveness;
- Reduced segregation;
- Reduced bleeding;
- Superior finishing;
- Higher ultimate strengths;
- Higher durability;
- Reduced permeability;
- Higher early strength.

Materials

Water reducers may contain a range of components including:

- Salts of ligno-sulfonic acids;
- Triethanolamine;
- Hydroxy-carboxylic acids;
- Biocides;
- Sugars – Polysaccharides – Carbohydrates.

Some of the water-reducing chemicals used may also have a natural retarding effect on the concrete and as a result Water Reducing Admixtures may contain a small amount of accelerator to offset any retardation. This effect enables a range of water reducing products to be produced – ranging from those with retarding capabilities; to those that are setting time-neutral; and through to those that have combined set accelerating and water reducing functions. This range of products is useful when changing from summer to winter conditions.

The degree of water reduction obtained is affected by:

- Type and concentration of admixture;
- Chemical composition of cement:
 - Water reduction is more noticeable in cements with lower alkali levels and lower C_3A ;
 - Different cement brands or cement sourced from different manufacturing plants may be affected differently.
- Cementitious content;
- Temperature of concrete;
- Time of addition to the mix;

- Delaying the addition until later in batching will increase the degree of water reduction.

The type of water reducer can be chosen to suit, amongst other things, the climatic or weather conditions.

Where set acceleration is required (in cold weather) then WRAc can be used.

Where set retardation is required (in hot weather) then WRRe can be used.

Mid-Range Water Reducers (Type MWR)

Mid-range water reducers act in the same way as Type WR water reducers but offer improved water reduction capability – in the order of 10-15%. Their similarity to the Type WR admixtures is such that no further elaboration is necessary.

High Range Water Reducers (Type HWR and HWRRe)

Major advances in concrete technology have been made following the development of high range water reducers. These admixtures are often called super-plasticisers and have exceptional water-reducing capability – usually between 15% and 25%. Their use has allowed concrete to be produced and used in a range of specialised applications including high strength concrete, high durability concrete and flowing (super-workable) concrete.

Benefits of Using High Range Water Reducers / Superplasticisers

- High level of water reduction;
- Superior workability;
- Improved concrete strength and durability;
- Very high workability for a short period.

The high water-reduction capabilities of super-plasticisers enables the production of concrete with very low water content – very close to the minimum required for hydration of cement.

Concrete meeting high strength/ high durability requirements, which cannot always be produced using normal ingredients, mixing, placing and curing practices, is generally referred to as High Performance Concrete (HPC).

The common denominator in all HPC is a low water/cementitious ratio (<0.35) from which follows high early strength, high durability, low shrinkage and long service life. However, these properties in the hardened state can only be achieved if the low W/C ratio concrete is fluid enough to allow proper placing and compaction, particularly in areas of congested reinforcement.

The use of super-plasticiser in high dosages in HPC mix designs can generate the twin characteristics of flowability and acceptable cohesiveness in the plastic state.

Super-plasticisers permit the production of 'self-compacting', 'self-levelling' or 'flowing' concrete (see Part VI, Section 22 of this Guide). These terms are prone to being misleading or misinterpreted and it may be inferred that these concretes 'place themselves'. Care is still required in placing these concrete products. Australian literature suggests the term 'Super-Workable Concrete' (SWC) should be used for these products.

SWC can best be described as a fluid concrete with a 'slump' in excess of 250 mm that is able to slump or 'flow' without segregation. It may have the same W/C ratio as that of a low slump concrete, but it can be (almost) self-levelling and will require only minimal compaction (**Figure 5.6**).



(a)



(b)

Figure 5.6 – (a) SWC Flowing Out of Slump Cone and (b) 'Slumped' SWC Showing No Segregation

Very low W/C ratio concrete produces high durability performance if proper placing and compaction techniques are followed. The use of super-plasticisers enables lower W/C ratios which in turn give lower concrete permeability that inhibits the flow of fluids (liquids or gases) through the concrete and which consequently should provide concrete with high durability performance.

Action

Very high workability ('slumps' >250 mm) can be produced to enable easy placement due to the almost 'flowing' concrete consistency. With the older superplasticisers this property was only maintained for a short period after which the flow characteristic reversed allowing normal finishing procedures to be used.

Current versions of these admixtures provide extended working times at the very high workability levels (**Figure 5.7**). Mix designs require special attention to avoid segregation and bleed problems and greater control over

batching and mixing and good supervision at the building site is necessary to ensure expected outcomes with these flowing concretes.

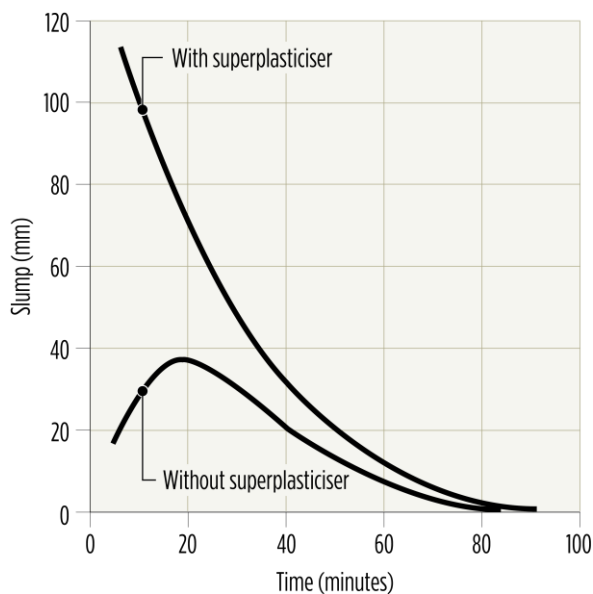

Figure 5.7 – Concrete Workability with and without Superplasticiser

Use of HWR

The admixtures are used in two main ways (Figures 5.8 and 5.9):

- To increase concrete workability greatly without changing other plastic properties;
- To increase the strength of concrete of a specified workability through large water reduction.

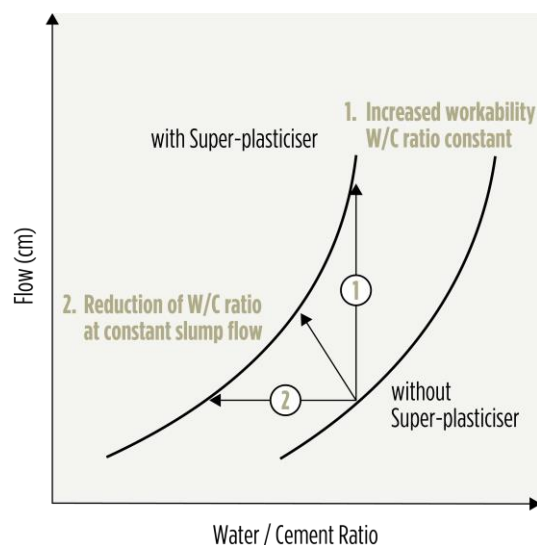

Figure 5.8 – Use of HWR to (1) Increase Workability or (2) Lower W/C Ratio (= Increased Strength)

There are many possibilities with these two types of applications that can be of benefit in concrete construction, including:

- Placing concrete in elements with congested reinforcing;
- Placing thin sections;
- Achieving high quality surface finishes;
- Increased pumping distances and heights;
- ‘Flowing’ concrete for large pours;
- Low noise situations – resulting from a reduced need for mechanical vibration.

When used specifically for SWC they are able to provide:

- Flow consistency;
- Low W/C ratio;
- High fines content;
- Good pumping;
- Segregation-free;
- Minimal bleed;
- Almost self-compacting and self-levelling.

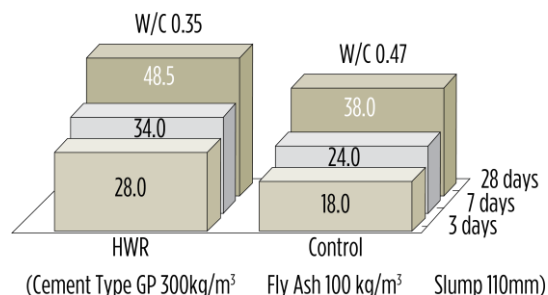

(Cement Type GP 300kg/m³ Fly Ash 100 kg/m³ Slump 110mm)

Figure 5.9 – Strength Improvement When Using HWR Through Reduced W/C Ratio

Superplasticisers used in high performance concrete are able to provide:

- Low W/C ratio to meet tough durability specifications;
- High workability;
- High early strength;
- High durability performance and long service life;
- Lower drying shrinkage in some circumstances.

While the very high workability concrete appears to self-compact, there may be a need

for some compaction to achieve the required performance properties.

(NOTE: Due to the very fluid nature of the concrete, the formwork will need to be sealed more tightly to prevent the flowing concrete flowing out of leakage points. Re-assessment of formwork pressures must also be made as the flowing concrete is not self-supporting and may require greater strengthening of the formwork (see Part IX, Section 27 of this Guide).)

Materials

There are a range of materials used as High Range Water Reducers, including:

- Sulfonated Melamine (SMFC) or Sulfonated Naphthalene (SNFC) Formaldehyde Condensates;
- Polycarboxylate polymers (PCE);
- Modified Lignosulfonates;
- Hydroxylated polymers.

The first two are the most common in use. They should not be used together as such a combination can result in severe slump loss. The SMFC and SNFC products were first introduced into the Australian market in about 1974.

The Polycarboxylates (PCE's) offer the newest technology and have tended to displace the sulphonated naphthalene and melamine formaldehyde condensates. The PCE's provide earlier action and work primarily by the action of steric hindrance in which the PCE attaches to cement particles and effectively pushes them apart. There is a wide variety of PCE admixtures possible, and they may be 'tailored' to achieve specific results. PCE's have a tendency to entrain air in concrete and always contain a de-foamer to reduce this tendency. It has been found that in some circumstances, the PCE admixture tanks must be continuously stirred to ensure that the de-foamer remains active. If the concrete materials contain any significant amounts of clay, PCE's can be adsorbed resulting in reduced efficiency. While PCE's can be used in virtually all concretes, they have been found to be particularly effective in low W/C ratio mixes.

The efficiency and effectiveness of the super-plasticisers depends on:

- Type and dose rate of super-plasticiser (**Figure 5.10**);

- Temperature of concrete;
- Composition of cement – *they perform better with higher alkali cements*;
- Cementitious content;
- Time of addition (though less so for PCE's);
- Presence of other admixtures;
- SCM's – very effective at dispersing SCM's (e.g. silica fume with a high surface area of about 20,000 m²/kg must be fully dispersed to achieve maximum efficiency);
- Mix design.

HWR additions may be made at the batch plant for those with longer action times, while on-site addition may be necessary for others.

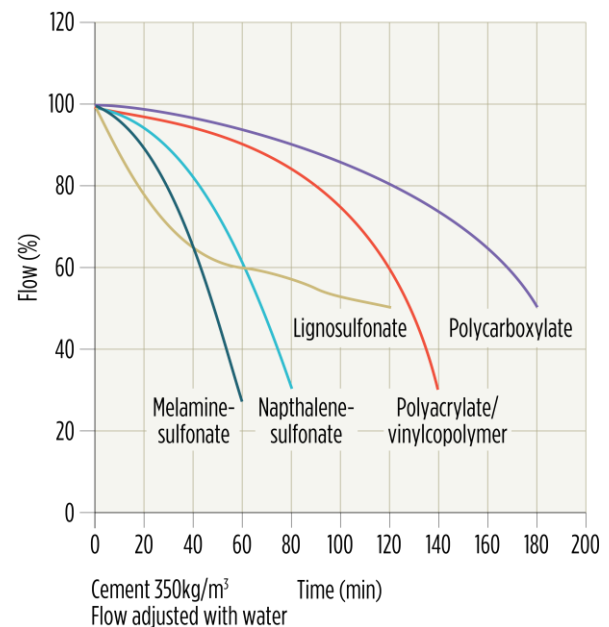

Figure 5.10 – Comparative Effectiveness of HWR Types

Testing Super-Plasticisers in Concrete

AS 1478.1 provides guidance on acceptability testing for all the chemical admixtures. The main test methods are listed in AS 1478.2.

Concrete Testing

Ideally, concrete trial mixes should use the cement, aggregate and other materials proposed for a project. Admixtures used must be added in the same dose and at same time in trial work as is proposed in practice.

Information provided with the trial mix test results must include the following test data for the cement:

- Name, type and source;
- SO₃ content;
- Type and quantity of mineral additions;
- Fineness;
- Sodium Oxide and Potassium oxide (i.e. alkali components).

Other Properties

Drying Shrinkage

High range water-reducing admixtures are expected to cause little or no increase in drying shrinkage. The reductions in total water and cement contents of concrete resulting from the use of these admixtures would be expected to lower drying shrinkage. **Figure 5.11** shows concrete samples with an initial slump of 45 mm and treated at different dose rates of super-plasticiser. All show minimal effect on drying shrinkage when compared to the Control sample.

DRYING SHRINKAGE (microstrain)

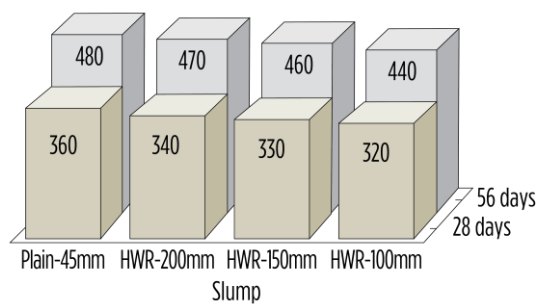

Cement-ACSC-401kg/m³
Concrete Temperature 23 °C

Figure 5.11 – Concrete Drying Shrinkage Minimally Affected by HWR Use

Slump Retention

Slump retention has been a major concern with super-plasticised concrete. With mixes designed as SWC or for high flow/spread, any significant loss of ‘slump’ can impact the intended application of the concrete. While when initially introduced PCE’s did experience difficulties with slump loss, this property has been much better managed with newer versions of these products. Some PCE’s now feature a ‘time-release’ function that provides slump control

over (relatively) long periods. This outcome can be achieved in several ways, including by using blends of two or more PCE’s to achieve the required properties at different times.

Super-plasticisers have been manufactured for hot weather applications with an in-built retarder to help provide slump retention. **Figure 5.12** shows the level of slump change of high range water reducers with and without retarders relative to a ‘plain’ concrete control.

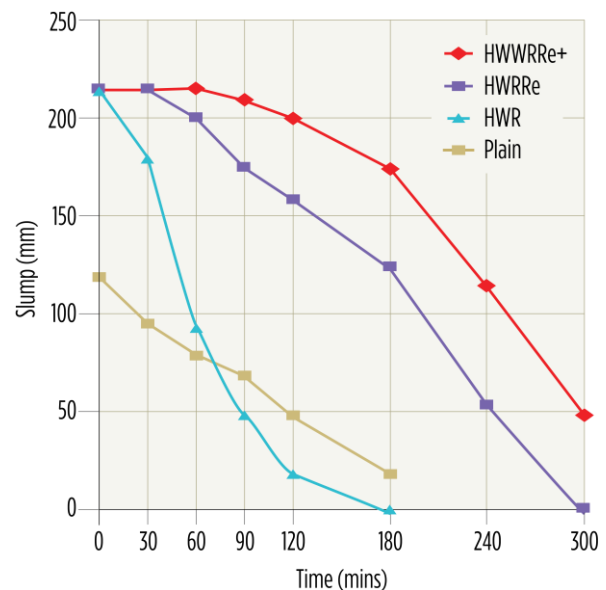

Figure 5.12 – Slump Retention When Using Several HWR Products

2.5 OTHER ADMIXTURES

There are a variety of highly specialised admixtures used in concrete projects. These admixtures are used much less frequently than the conventional admixtures previously described but are important in that they (a) increase the range of applicability of concrete as a construction material, and (b) improve concrete performance in (often) extreme conditions.

Shrinkage Reducing / Compensating Admixtures

Reducing the drying shrinkage of concrete has been an elusive goal for years and admixtures have now been developed to assist in achieving this.

Some shrinkage compensating admixtures make use of an expansion mechanism within the cement paste to counter any shrinkage that occurs. There are several methods of achieving this outcome including (a) rapid oxidation of iron particles deliberately added to the mix, and (b) hydrogen gas generated from fine aluminium powder particles (aluminium reacts with lime to produce hydrogen gas). These techniques have been mainly used in grouting applications.

More recent developments in Shrinkage Reducing Admixtures (SRA's) for concrete have included the use of ethylene and propylene glycol derivatives that act on fine capillaries in the concrete, reducing surface tension within the pore solution which helps prevent the collapse of capillary walls which leads to reduced shrinkage and cracking (**Figure 5.13**). These SRA's also affect air entrainment and compressive strength performance. Compressive strengths can be reduced by 10-15% by using these SRA's and mix designs need to be amended to compensate for this effect.

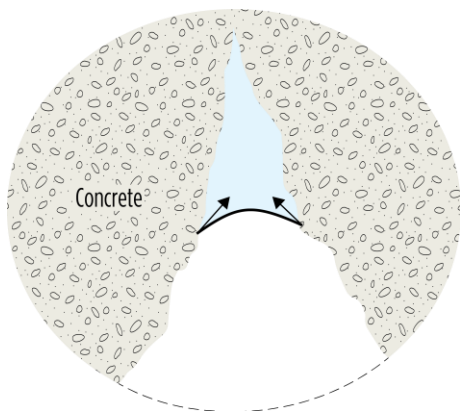

Figure 5.13 – SRA's act by Reducing Surface Tension of the Menisci in the Capillary Pore System

SRA Effectiveness is impacted by:

- Cement content – High cement contents result in greater expansion;
- SCM type and proportion;
- Aggregate type and grading;
- Curing method – Water curing gives greater expansion;
- Mix temperature – Higher temperatures reduce expansion;
- Interaction with other admixtures:

- Using SRA's and AEA's may cause excessive air entrainment;
- Accelerators offset some of the benefits as they may increase shrinkage.
- Combinations with other admixtures:
 - Super-plasticisers plus accelerator give greater expansion;
 - Retarders give greater expansion.
- High levels of reinforcement restrain expansion.

Corrosion Inhibitors

In certain environments, concrete requires high durability performance to withstand the intrusion of chloride ions which may corrode embedded reinforcing steel. Structures such as wharves and other buildings in marine environments, including bridges, are particularly at risk. The factors needed for corrosion to be propagated are:

- Moisture;
- Oxygen;
- Electrochemical reaction (creation of a galvanic cell).

Chlorides can initiate and accelerate the corrosion process. High quality concrete and good concreting practices are needed to ensure high durability and these fundamentals should be met before considering corrosion inhibitors as an adjunct protective measure. It is imperative that concrete placed in or adjacent to a marine (or other chloride-rich) environment has very low permeability to slow down chloride ion penetration.

Steel embedded in concrete is naturally 'passivated' because of the pH of the concrete paste. ('Passivation' means the creation of a thin, stable iron oxide layer that prevents steel from corroding.)

Corrosion occurs when electrochemical (galvanic) cells are created on the surface of the embedded steel when the protective passivating layer has been disrupted. Loss of passivation can occur if the pH of the concrete paste is reduced significantly (to about a pH of 10), or if the layer is breached or disrupted by some ions, including chloride ions.

During corrosion, steel is consumed at the anode of the cell(s) and 'rust' is created at the cathode. The 'rust' occupies a much larger volume than the original steel and the pressure from this greater volume of material creates tensile stresses in the concrete, leading to cracking. Once cracking occurs, the corrosion reaction can be accelerated by intrusion of greater quantities of aggressive agents through the cracks.

Some corrosion inhibitors promote and reinforce the passivating layer that naturally forms on steel in its alkaline environment, while others act as a surface coating to limit the cathodic reaction. Some of these corrosion inhibitors may also chemically 'fix' the chloride ions to prevent them from reaching the steel in the first place.

Materials

Corrosion-inhibiting admixtures are usually in liquid form and added to the concrete at the batching stage, though some are applied as surface coatings.

Types

Corrosion inhibitor types are described in terms of their mode of action, namely:

- Anodic;
- Cathodic;
- Mixed.

Anodic inhibitors enhance steel passivation and help prevent the anodic reaction. Cathodic inhibitors coat the steel surface to prevent the cathodic reaction occurring. Mixed inhibitors contain compounds that act on both anodic and cathodic sites on embedded steel.

Inhibitors may be inorganic materials, organic materials or combinations of both. Typical compounds used are:

Anodic Inhibitors – Nitrates, Nitrites, Chromates, Phosphates, Tungstates and Molybdates.

Anodic Inhibitors may be oxidising agents or non-oxidising agents and act by strengthening the passivating oxide layer on the surface of the steel reinforcement – a layer that can otherwise be broken down by the action of chloride ions. These agents may also alter the electrical

potential at the steel surface to decrease the corrosion rate. The oxidising agents (chromates, nitrites etc.) act directly on the steel, while the non-oxidising agents (phosphates etc.) require the presence of oxygen to passivate the steel. Calcium nitrite is a well-tried inhibitor and considerable history of its use exists. Calcium nitrate can also be used though it tends to have reasonably significant impacts on plastic concrete properties. If the levels of these oxidising inhibitors drop below a critical limit, this can initiate pitting corrosion.

Cathodic Inhibitors – Zinc and Magnesium salts, Phosphates and Silicates

Cathodic inhibitors act by coating the surface of the steel – usually by precipitation of insoluble compounds on the steel surface – and when working properly, form a barrier film that prevents cathodic reactions from occurring. These agents are not as effective as anodic inhibitors but will not initiate pitting attack.

Mixed (Organic) Inhibitors – Amines and Amino-Alcohols

These chemicals inhibit both anodic and cathodic reactions and do so by forming adsorbed, hydrophobic coatings on the steel surface.

The various inhibitor types are generally added to the concrete mix at the time of batching. As they are required in quite large quantities (20 litres per cubic metre is common) they can have some impacts on workability and setting time.

Some of these inhibitors (particularly Cathodic and Mixed types) can also be applied to the surface of the concrete from where they gradually penetrate into the concrete until they reach the surface of the reinforcing steel.

Hydration Control Admixtures (Type HCA)

Hydration control admixtures are designed to control the rate of hydration of the cement. They differ from retarding admixtures in that they also affect the C₃A hydration.

Components

HCA systems have two components:

- A stabiliser which allows freshly batched concrete to remain plastic for extended periods of time;

- An activator which restarts the hydration process when desired.

The stabiliser suspends the hydration reaction through being readily adsorbed onto the cement particles and interacting with the cement hydration products, effectively suspending hydration. It can deactivate the concrete for hours or even days.

The activator is then used to reactivate the cement hydration reaction so that the concrete can be handled and finished in the normal manner.

The products are very useful for long hauls and where delays occur, and their use results in little adverse effect on the plastic or hardened properties of the placed concrete. If the activator is used to accelerate setting time, then some small strength loss may occur, and mix designs may require alterations to offset this effect.

HCA systems are used extensively in shotcrete applications (**Figure 5.14**) particularly in mining projects where batching operations, shift work, equipment breakdowns are all important economic considerations for concrete (and mine) production. HCA systems allow shotcrete to be 'put to sleep' from 3-72 hours depending on dosage and to be 're-awakened' at any stage.

TRADITIONAL SHOTCRETE 1-2 HRS

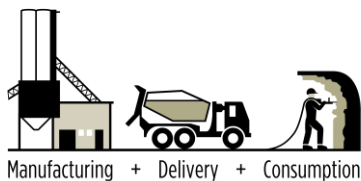

HCA ADMIXTURE ADDED



Figure 5.14 – HCA Used to Extend Working Time

Once activated by dosing the activator at the nozzle prior to spraying onto the vertical surface, the shotcrete begins setting by the time

it hits the surface and may achieve initial set in about one minute and final set in 6-8 minutes.

The liquid activator admixture is provided through a separate injector at the nozzle and mixes in with the concrete materials in the sprayed concrete stream.

In addition to providing rapid set times the admixture also increases the cohesiveness of the concrete and permits thicker layers to be sprayed with minimal rebound and slumping.

Through using these admixtures, strength development at early ages is improved, and comparable 28-day strengths are also obtained.

Anti-Washout Admixtures (Type AWA)

Anti washout admixtures are used for placing concrete underwater – a situation where part of the cement paste is normally washed away during the placing process. These admixtures reduce the quantity of the paste that is lost and also create a flowing concrete product. Their use can result in lower concrete compressive strengths.

The concrete produced with AWA is very cohesive and has a high flow characteristic. The admixture enables the concrete to resist segregation and sagging but enables it to be readily pumped – albeit with higher pump pressures.

These products are sometimes referred to as Viscosity Enhancing Admixtures.

Materials

The admixtures generally contain polymers, flocculants, organic emulsions and fine inorganic materials. They may be made from cellulose, synthetic polymers and organic gums such as Whelan, Guar and Eanthate gum.

Benefits

- Greater cohesiveness;
- Less segregation;
- Minimal bleed;
- Extended setting times.

Negative Aspects of AWA Use

- Some reduction in compressive strength.

Their effectiveness is affected by:

- Cement content;
- Concrete temperature:
 - High temperatures give slump loss and the mix requires retardation.
- Fine aggregate:
 - If it is too fine, it may impair workability.
- Other admixtures:
 - Not used with retarders;
 - Not used with water reducer-retarders;
 - May result in excessive air entrainment.

Permeability Reducing Admixtures (PRA's)

These materials are designed to decrease the permeability of concrete. They are sometimes loosely termed damp-proofers or water-proofers. Names such as these are misleading, and most products simply slow down the rate at which moisture penetrates the concrete by absorption or diffusion rather than stopping its movement entirely.

There is a wide variety of materials on the market and individual assessments are required for each material and each project. These admixtures reduce the migration and diffusion of moisture through the capillary pores of concrete using either a pore blocking or hydrophobic layer process.

Pore Blockers

SCM's and other high fineness materials can act as pore blockers.

Some permeability-reducing admixtures form crystalline, fibrous structures by reacting with products (typically lime) from the cement hydration reaction and these fibres/crystals form in the pores in the paste and block moisture movement.

Hydrophobic Agents

These agents coat the inside of capillary pores and effectively push water out of the pores. The hydrophobic agents are typically compounds based on stearic acid and other fatty acids or are derived from vegetable and animal fats and waxes.

Benefits

While PRA's will slow the rate of moisture movement in the concrete, they may also have other effects that need to be assessed using trial mixes. Impacts on strength and strength variability should always be checked prior to using these materials.

It is important to note that PRA's will not overcome issues due to poor quality concrete, poor concrete placing processes or design flaws. Voids from poor compaction, plastic shrinkage cracking or other cracks and lack of curing are all factors that facilitate water movement and create conditions that cannot be overcome simply by using PRA's.

Internal Curing Admixtures

Internal curing admixtures are intended to assist with the hydration of concrete in a manner similar to that of a curing compound – that is, by retaining water from within the concrete that might otherwise be lost by evaporation. It is claimed that they provide similar benefits to a good curing compound.

The admixtures are typically water-soluble polymers that reduce the rate of evaporation of water from the concrete by 'binding' the water through the formation of hydrogen bonds between the water and polymer molecules.

***NOTE:** Another version of internal curing comes from the use of pre-moistened lightweight porous aggregate in concrete manufacture. These aggregates release water slowly into the hardened concrete and provide additional water for hydration as the concrete ages.*

Anti-Freeze Admixtures

These are not in great demand in Australia but are essential in areas where concreting must occur at temperatures at or below zero degrees Celsius.

They are intended to ensure the concrete will not freeze while in the plastic state and do this by depressing the freezing point of the mix water.

They may contain water reducing agents and/or accelerating agents and generally very good concrete strengths can be obtained when these admixtures are being used.

Foaming Admixtures

Foamed concrete may be used where lightweight materials are required or where concrete is required to have acoustic or thermal insulation characteristics.

The admixtures are supplied in powder, liquid or a stable foam form and can be designed to promote stable air contents at levels as high as 15-30%.

Other uses for foamed concrete include cavity filling of disused tunnels, tanks and mines and the encasement of in-ground pipelines with low strength fill.

3 GUIDANCE ON THE USE OF ADMIXTURES

Admixtures are not considered to be a substitute for good concrete materials, correct mix design and good concreting practice. However, they can offer more economical ways of adapting concrete than using continual changes in mix designs and can offer performance not possible using basic concrete technology.

It is important to recognise that reactions between admixtures, and with different types of cement, can change the effectiveness of a given admixture.

Incompatibility

There are two areas requiring caution, namely:

- Admixture – admixture interaction;
- Cement – admixture interaction.

There may be chemical reactions between cement hydrates and admixtures and there may be situations when changes in the physical nature of the cement (e.g. fineness) will impact on the effectiveness of an admixture.

Admixture – Cement Reactions

Most admixtures can be affected by the physical properties of a cement as their mode of action is via reaction between the admixture and the cement hydrates.

It is important to understand these effects to get the best results (or optimum use) and to assist in analysing problems in the field. Trial mixes

provide one way of pre-determining the nature and extent of admixture – cement interactions.

Examples of Admixture – Cement Reactions

- Water Reducers – WR are most effective with low C_3A and low-alkali cements. An increase in C_3A from 6% to 12% can reduce the effectiveness of a WR by up to one-third. An increase in (total) alkali content from 0.55% to 0.8% can see a similar reduction;
- AEA's – The effectiveness of AEA's can be impacted by both cement fineness and cement alkali content. Neither property normally varies greatly for a constant cement supply, but changes in cement supplier may require a review of admixture dose rates;
- Blended cements may impact admixture dose rates. Some SCM's may adsorb WR's or AEA's, and variable LOI in fly ash used for Type GB (Fly Ash) products may affect levels of air entrainment.

General Precautions

Concrete manufacture involves management of a wide range of variables in terms of materials and batching systems as well as weather conditions. Admixture use can provide higher levels of consistency in many cases but may also contribute to increased variability if uncontrolled changes occur.

Always be aware of:

- Change in type, source, composition and amount of cement;
- Change in SCM properties;
- Changes in aggregate and sand grading;
- Modifications to mix proportions;
- Combinations of admixtures that may adversely affect other properties;
- Temperature conditions;
- Previous use-history for admixture combinations.

NOTE: Always check what 'Chloride-Free' means – not many materials are absolutely chloride-free (e.g. water).

Using trial mixes is the best way of determining what effects various combinations of materials may yield.

Once material combinations and mix designs have been determined, monitor uniformity for all materials being used.

This approach also applies to admixtures where the solids contents, specific gravity and active ingredient proportions should be regularly checked.

NOTE: *Never assume that a category of product from one supplier will perform in the same way as a 'similar' product from another supplier as they may use different source materials or have different manufacturing processes.*

4 AUSTRALIAN STANDARDS AS 1478 – PARTS 1 AND 2

AS 1478.1 provides the general standard covering the types of admixtures and their use. It provides performance limits for chemical admixtures and stipulates what must be disclosed about the ingredients used in the admixtures.

Performance limits are set for:

- Water content of the concrete as a percentage of the Control;
- Time of setting as an allowable deviation from the Control;
- Compressive strength at 1, 3, 7, 28, 90 days as percentage of Control results;
- Measurement of drying shrinkage.

AS 1478.2 provides the methods for sampling and testing admixtures for concrete mortar and grout to determine compliance with performance stipulated in AS 1478.1.

AS 1478.1 includes:

- Sampling procedures;
- General information on admixtures;
- Guide to determining the chloride ion content;
- Information to be supplied on admixture:
 - Name and type.
- Compliance dose rate;
- Recommended dose rate;
- Chemical composition:
 - Chloride ion content;
 - Triethanolamine content.
- Compatibility with other admixtures;

- Sequence of addition;
- Use by date;
- Test procedures;
- Acceptability limits;
- Frequency of testing.

Acceptance Testing for Admixtures

These tests are generally done before introduction of the product into the concrete market.

Testing should include preparation of concrete mixes and assessment of:

- Water content;
- Strength;
- Drying shrinkage;
- Air content;
- Bleed testing may be done with selected products e.g. AEA;
- Time of setting may be done on selected products e.g. accelerators and retarders.

The Standards indicate the degree of variation from control samples permitted in these tests.

Certain product and test parameters must always be noted, including product type, source and properties of the cement with which the admixture is tested (including information on SO₃ content, fineness, total alkali contents and the presence of any mineral additions).

Similar requirements apply for other materials e.g. SCM's, aggregate and sand.

Uniformity tests are performed on the admixture, for properties including:

- pH;
- Relative density;
- Non-volatile content;
- Chloride ion content.

5 CHOOSING AN ADMIXTURE

Before using an admixture, it is important to understand:

- The intended purpose;
- The ingredients in the admixtures;
- The likely compatibility with other admixtures being used;

- The history of the use of the admixtures with the cement and SCM(s) being used;
- The likely need for mix changes;
- The timing of admixture addition to the mix;
- The need for any additional supervision.

Where there is no historical evidence about performance or where some conditions are unknown, trial mixes should be carried out to assess the product performance in the proposed concrete prior to commencing the project.

6 ADMIXTURE DOSE

Admixtures other than the Superplasticisers are dosed in very small quantities and proper dispensing equipment is important to maintain that level of dosage accurately. The dosing systems are normally set up in the batch plant.

The dose rate will vary with a range of parameters including:

- Properties sought;
- Seasonal temperatures;
- Concrete grade;
- Combinations of admixtures in use;
- Cement chemistry;
- SCM use – type and proportion.

Overdose Effects

Overdosing of an admixture will obviously produce an exaggerated effect of the property it is designed to modify. Some of the impacts of overdose are shown in **Table 5.2**.

The extent of actual effects will depend on:

- Type of concrete;
- Type of admixture;
- Overdose factor;
- Ambient conditions.

Table 5.2 – Effects from Admixture Overdose

Admixture Type	Some Typical / Possible Effects
Retarders	Long setting times Increased plastic cracking risk Surface crusting
Accelerators	Rapid setting Finishing issues likely Lower long-term strength
Water Reducers	Variable set times Excessive air entrainment Lower strengths
Water Reducer – Retarders	Long setting times Excessive air entrainment Lower early-age strength
Water Reducer – Accelerators	Erratic setting Excessive air entrainment Lower later-age strength
High-Range Water Reducers	Severe segregation Retardation of set times

Example

Overdosing with a Water Reducer – Retarder (Type WRRe) may create the following effects:

Plastic Concrete:

- Excessive retardation;
- Copious bleed;
- Crusting of surface;
- Plastic shrinkage cracking.

Hardened Concrete:

- Surface dusting / poor finish;
- Loss or increase in strength.

7 SUMMARY – ADMIXTURES FOR CONCRETE

Type	Application	Effect	Comment
Air-Entraining (AEA)	To enhance freeze/thaw resistance; To increase workability.	Produces a large number of small air bubbles in the concrete paste.	Efficiency is reduced by increases in temperature, high cement content and by the presence of fly ash with high LOI.
Set-Accelerating (Ac)	For cold-weather concreting; To permit early finishing; To permit early formwork removal; To expedite completion of structure or repair.	Shortens setting time; May increase early strength of concrete; May reduce long-term strength.	Overdosing may lead to the very rapid set of concrete and to reduced ultimate strength. Products containing chloride ions (e.g. calcium chloride) have the tendency to promote corrosion of any embedded metals.
Set-Retarding (Re)	For hot-weather concreting; To facilitate the use of delayed finishes; For mass concrete; To eliminate cold joints.	Delays setting of concrete; Reduces early strength of concrete (up to 7 days).	Overdosing may lead to excessive retardation and delays in the development of concrete strength (in severe cases up to several days). Generally, later-age strengths are not affected.
Water-Reducing (WR, WRRe and WRAc) <i>[NOTE: Mid-range water-reducing (Type MWR) offer greater water reduction than Type WR.]</i>	To increase workability; To increase strength at same workability; A combination of the above two applications; To improve properties of concrete incorporating poorly graded aggregates.	Disperses cement particles and increases the fluidity of the concrete; Reduces the water demand of the mix; May affect setting time (retard or accelerate) depending on the formulation of the admixture.	Overdoses of lignosulphonates may cause excessive retardation and excessive air entrainment with subsequent effect on strength. The chloride content should be ascertained. PCE's need de-foamers to prevent high air levels.
High-Range Water-Reducing – Superplasticisers (HWR and HWRR)	To facilitate placing and compacting (e.g. in heavily reinforced members); To increase strength; For the provision of high-quality formed surfaces; To facilitate pumping.	Increases the fluidity of the concrete and can be used to produce concretes with very low water/cement ratios.	Compatibility with other admixtures in the mix should be checked. Re-tempering of the concrete more than once to restore slump is not recommended.
Thickening	To facilitate pumping over greater distances at lower pressure; To improve lubrication and reduce segregation.	Increases the viscosity of the cement paste.	Will not convert unpumpable concrete into pumpable concrete – the mix must be designed specifically for pumping.
Shrinkage-Reducing	To offset volume change (in concrete, mortar and grout); For grouting of anchor bolts, prestressing ducts and prepacked-aggregate concrete; For bedding of machines and columns; For underpinning; To produce self-stressed concrete.	Some SRA's work in the plastic state and others in the hardened state.	Excessive dosage of the admixture, or the presence of unsuitable combinations of admixtures (or of admixture and cement) could generate excessive expansive forces that disrupt the concrete, mortar or grout. High doses of liquid SRA's may affect compressive strengths and consideration should be given to the combined use with a superplasticiser.
Permeability-Reducing	To reduce transmission of fluids.	Fills the capillary pores with reactive, inert or water-repellent materials.	Will not convert poor-quality concrete into water-tight concrete.

8 RELEVANT AUSTRALIAN STANDARDS

- 1) AS 1478 – *Chemical admixtures for concrete, mortar and grout*
- 2) AS 1478.1 – *Admixtures for concrete*
- 3) AS 1478.2 – *Methods of sampling and testing admixtures for concrete, mortar and grout*
- 4) AS 2072 – *Methods for the sampling of expanding admixtures for concrete, mortar and grout*
- 5) AS 2073 – *Methods for the testing of expanding admixtures for concrete, mortar and grout*
- 6) AS 1379 – *Specification and supply of concrete*
- 7) AS 3600 – *Concrete Structures*

CONTENTS

1	OUTLINE	2
2	REINFORCEMENT TYPES.....	2
2.1	GENERAL	2
2.2	STANDARD BARS	2
2.3	MESH REINFORCEMENT.....	4
2.4	STAINLESS STEEL BARS	5
3	PRESTRESSING WIRE, STRAND AND BARS.....	6
3.1	TENDONS.....	6
3.2	IDENTIFICATION OF PRESTRESSING WIRE, STRAND AND BARS.....	9
4	OTHER PROPERTIES OF REINFORCEMENT, PRESTRESSING WIRE, STRAND AND BARS.....	9
4.1	ELASTIC MODULUS	9
4.2	COEFFICIENT OF THERMAL EXPANSION.....	9
5	REFERENCES.....	10

1 OUTLINE

Reinforced concrete and prestressed concrete are composite materials made up of concrete and some form of reinforcement – most commonly steel rods, bars, mesh, wire or strand.

The reinforcement in reinforced concrete is usually provided by steel bars that may also be in the form of a welded mesh. Bars are normally associated with beams and columns and mesh with floors and walls. However, mesh may also be used in beams and columns with bars often used in floors.

In prestressed concrete the prestressing may be in addition to standard reinforcement. The prestress forces are provided by wire, strand or hot rolled bars.

This section provides basic information on the identification of and key specified properties of reinforcing and prestressing wires, strand, bars and mesh for use in concrete. It also provides

information on the types of reinforcement and prestressing wires, strand and bars used in Australia.

2 REINFORCEMENT TYPES

2.1 GENERAL

Steel reinforcement is defined in AS 3600 as ‘*steel bar, wire or mesh but not tendons*’. This definition precludes the use of non-tensioned prestressing materials (strand, bars and wires) as reinforcement if the structure is to comply with the Standard. It also requires that reinforcement be deformed bars or mesh except that plain bars may be used for fitments.

The Concrete Structures Standard (AS 3600) refers to AS/NZS 4671 for reinforcement types and quality.

2.2 STANDARD BARS

In Australia, reinforcing bars are manufactured to comply with the requirements of AS/NZS 4671. There are a number of processes by which they can be manufactured and these, along with the chemical composition of the steel, can significantly affect the properties of the bar.

‘Microalloy’ reinforcement is produced by adding small amounts of an alloy, e.g. niobium and/or vanadium to the steel during its manufacture. During the hot-rolling process, these precipitate as very fine nitrides or carbides which help increase the minimum yield strength. Microalloy bars are produced in sizes up to 20 mm in Australia and also larger than 36 mm with limited quantities.

‘Quenched and self-tempered’ (QST) reinforcement is produced by the controlled water quenching of the outer layers of hot-rolled bar, thereby hardening it and increasing the minimum yield strength. At the same time, the process preserves the excellent durability and weldability of the parent material.

Both processes can achieve satisfactory bendability, re-bendability and weldability in high-strength bar. Nevertheless, all reinforcing

bars do not behave in the same manner in respect of these properties. Care should therefore always be taken to ensure that reinforcing bars comply with the requirements of AS/NZS 4671.

The Australasian Certification Authority for Reinforcing and Structural Steels (ACRS) is an independent body formed in 2000 to undertake third-party product certification on steel reinforcing bar, wire and prestressing tendons. Modelled on CARES in the UK, ACRS certification ensures end-user confidence that supplied reinforcement materials meet the relevant Australian Standards. More information on ACRS is available on their website 'steelcertification.com'.

Classification and Designation of Reinforcement

In accordance with AS/NZS 4671 requirements, reinforcing steel is classified by: profile; strength grade; relative ductility and size.

Profile

Reinforcing bars can be either plain, deformed ribbed or deformed indented. The profiles are designated by the letters R (Round), D (Deformed ribbed) and I (deformed Indented) respectively. Generally, only D (Deformed ribbed) bars will meet the intention of the requirement in the concrete design Standards that reinforcement be deformed. However, Section 7.4 of AS/NZS 4671 contains a test method to measure the bond performance of indented bars or ribbed bars with ribs not meeting the specification set out in AS/NZS 4671.

Strength Grade

The tensile strength of reinforcement measures how strong it is when it is pulled or stretched. When steel is stretched and then released, it will return to its original length provided it is not overloaded (i.e. it will behave elastically). As the tensile load increases, a point will be reached where it will not recover (the steel is permanently stretched or has yielded). The steel is then classified as having a certain yield strength – the stress at which it first began to yield. The unit used for 'yield stress' is MPa.

Strength grade is designated by the numerical value of the lower characteristic yield stress – typically 250, 500, 600 and 750 MPa.

Reinforcing steel with a strength grade above 250 MPa is also required to comply with the specification of an upper characteristic yield stress. The upper characteristic yield stress will not exceed the lower yield stress by more than the values given in AS/NZS 4671.

There are also limits on the minimum strain in the steel at yield stress for all reinforcement types according to the Ductility Classes of steel.

All steel has limits on carbon, sulfur and phosphorous content.

Ductility Class

The relative ductility of steel reinforcement is identified by a Ductility Class of 'L', 'N' or 'E' representing, in order, Low Ductility, Normal Ductility or Earthquake (high) Ductility. Each is specified by a minimum ductility ratio (steel tensile failure stress at maximum force divided by the yield stress).

Identification of Standard Grades of Reinforcement

The standard grades of reinforcing steels can be identified by either an alphanumeric marking system on the surface of the bar or by a series of surface features on the product at intervals of not more than 1.5 m (see **Figure 6.1**). In addition, deformed reinforcement has to carry marks enabling the steel producer to be identified.

Further, AS/NZS 4671 sets out requirements for the labelling of each bundle of reinforcing steel or mesh (see Clause 10.3).

Table 6.1 provides design data related to common reinforcing bar sizes used in Australia.

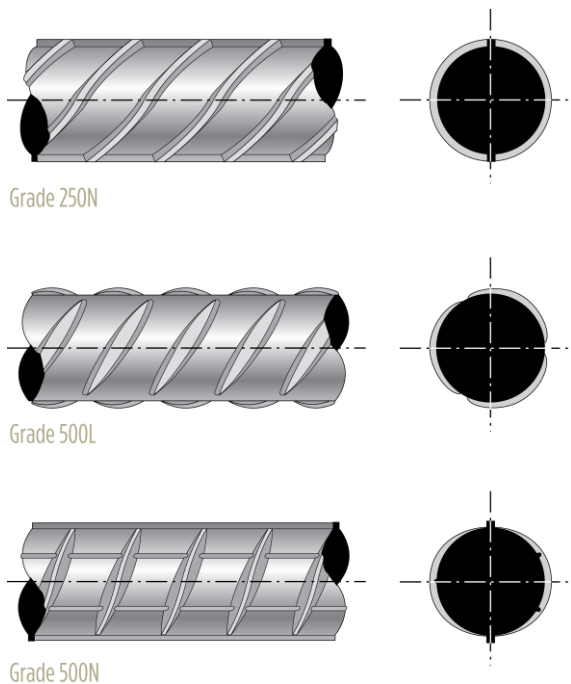

Figure 6.1 – Examples of Grade Identifiers (Refer to AS/NZS 4671 for Other Grade Examples)

Table 6.1 – Design Data for Reinforcing Bars in Australia (from Table 7.5(A) of AS/NZS 4671)

Nominal diameter (mm)	Cross-sectional area (mm ²)	Mass per metre length (kg/m)	Strength and ductility class
10.0	78.5	0.617	500N
12.0	113	0.888	500N
16.0	201	1.58	500N
20.0	314	2.47	500N
24.0	452	3.55	500N
28.0	616	4.83	500N
32.0	804	6.31	500N
36.0	1,020	7.99	500N
40.0	1,260	9.86	500N
50.0	1,960	15.4	500N

Weldability

Reinforcement conforming to AS/NZS 4671 is weldable. Depending on the manufacturing process used and the chemical composition of the steel, requirements for welding may vary.

Designers should consult the manufacturer's literature for specific advice. Welding should be carried out in accordance with AS 1554.3. More detailed information and guidance can be gained from Weld Australia technical notes. Note that 500 MPa reinforcement manufactured overseas may not conform to AS/NZS 4671. It may have a higher carbon equivalent content, making the requirements for welding more stringent.

Generally, welding reinforcement complying with AS/NZS 4671 will require:

- The use of hydrogen-controlled electrodes;
- The use of special precautions in adverse conditions, e.g. wet weather, temperatures $\leq 0^{\circ}\text{C}$;
- The use of preheating when bars over 25 mm diameter are being welded.

Note the limitation on the location of welds in a bar that has been bent and re-straightened (Clause 13.2.1(f) of AS 3600), i.e. it shall not be welded closer than $3d_b$ to the area that has been bent and re-straightened.

Bending and Rebending Reinforcement

AS/NZS 4671 specifies for bars of diameter ≤ 16 mm a 90° bend and rebend test and for bars > 16 mm a 180° bend test. These requirements will ensure that bars likely to be re-straightened in the field, i.e. with $d \leq 16$ mm, will still satisfy the required ductility.

2.3 MESH REINFORCEMENT

Manufacturing Process

Mesh reinforcement consists of a grid of cold-rolled steel bars welded together in a regular pattern (either square or rectangular). The bars used in the manufacture of mesh may be plain, deformed or indented, and are required to comply with the requirements of AS/NZS 4671. Deformed bar is the more widely used, but wire or indented bars may be appropriate for certain applications.

Mesh is manufactured on automatic machines that weld 'transverse' bars to the 'longitudinal' bars to produce a mesh that is then cut to

standard lengths. The longitudinal bars may vary in diameter between 4 and 11.9 mm. When the mesh pattern is square, the transverse wires are the same diameter as the longitudinal wires. Rectangular mesh has transverse bars from 7.6 mm to 11.9 mm diameter at a pitch of 100 mm or 200 mm regardless of the diameter of the longitudinal bars.

Designation of Welded Mesh

Welded mesh is designated in a similar fashion to reinforcing steel. The designation reflects:

- *Profile* – the shape of the bars by the letters; R (Round), D (Deformed) or I (Indented);
- *Strength grade* – by the numerical value of the lower characteristic yield stress;
- *Configuration of orthogonal bars* – by the letters S (Square) or R (Rectangular) configuration;
- *Ductility Class* – by the letters L (Low), N (Normal) or E (Earthquake);
- *Size* – by the numerical value of the nominal diameter of the longitudinal bar expressed in millimetres;
- *Transverse spacing of the longitudinal steel* – by the numerical value of the transverse spacing expressed in millimetres divided by 100; and
- *Transverse reinforcement in rectangular meshes* – by the numerical value of the nominal diameter expressed in millimetres.

Mesh is designated by listing the above designators in the order of profile, strength, configuration, ductility, size and spacing. For example, a square mesh consisting of nominal 9 mm diameter deformed ribbed bars at 200 mm centres, of Grade 500 low ductility steel is designated 'D500SL92'. If all the welded mesh ordered or required for the project was to be deformed ribbed bars, of the same strength, then the designation for that project could be abbreviated to 'SL92'.

Table 6.3 sets out meshes commonly available in Australia.

Mesh is most commonly used in slabs and walls. Rectangular mesh is used in road

pavements and slabs that span one way or are rectangular, whereas in slab-on-ground construction square mesh is most popular.

Special meshes include: 'girder wrap' for use in fire protection work; 'trench mesh' for use in footings in domestic and other low-rise structures; and mesh made with Ductility Class N bar. Mesh can also be bent to form reinforcing cages or fitments for beams and columns.

2.4 STAINLESS STEEL BARS

Stainless steel reinforcement is becoming more readily available and is sometimes used in extremely aggressive situations where its higher cost can usually be justified. It is not required to be isolated from normal reinforcement and can be used in locations which are subjected to aggressive exposure while normal reinforcement is used in more protected locations. Stainless steel can be welded using appropriate electrodes and techniques. Care is required when fabricating and bending it to prevent contamination from normal reinforcement.

Stainless steel reinforcement properties are required to be in accordance with AS 3600 which refers to British Standard BS 6744. It is estimated that the stainless-steel reinforcement complying with BS 6744 has a ductility class equivalent to AS/NZS 4671 Class N. Two characteristic yield strengths are used in Australia – 200 MPa and 500 MPa (see **Table 6.2**).

There can also be a significant loss of bond with plain stainless-steel bars but, for deformed bars, the bond strength is similar to that for normal reinforcement.

Table 6.2 – Yield Strength and Ductility Class of Reinforcement (from Table 3.2.1 of AS 3600)

Reinforcement		Characteristic yield strength (MPa)	Characteristic uniform Strain at maximum stress (strain)	Ductility Class
Type	Designation Grade			
Plain Bar to AS/NZS 4671	R250N	250	0.05	N
Bar deformed to AS/NZS 4671	D500L (fitments only)	500	0.015	L
	D500N	500	0.05	N
Welded mesh, plain, deformed or indented to AS/NZS 4671	D500L	500	0.015	L
	D500N	500	0.05	N
Stainless steel plain bar to BS 6744	200	200	0.05	N or E
Stainless steel ribbed bar to BS 6744	500 ^(*) <i>(*) Maximum Grade allowed by AS 3600 and AS 5100.5</i>	500	0.05	N or E

3 PRESTRESSING WIRE, STRAND AND BARS

3.1 TENDONS

General

The steel wires, strand and bars used in prestressed concrete are often referred to as 'tendons'. Tendons used in prestressed concrete are generally manufactured from high tensile steel. The tendons may be 'normal stress-relieved' or 'low-relaxation stress-relieved', although the latter is by far the more common.

When steel is tensioned to a high stress, and then held at a constant length under that stress, there will be a loss of stress in the steel as it 'relaxes' under the load. Low-relaxation steel is commonly specified because it can maintain a higher tensile stress over time than normal steel. Normal-relaxation and low-relaxation steel are not therefore directly interchangeable.

All prestressing tendons should carry a mill certificate from the manufacturer (or a nominated testing authority) which clearly identifies them. Particular attention should be paid to the physical and chemical properties of the steel, protective coatings, physical damage, corrosion, and to its handling and storage.

Rejected material should be clearly marked and removed from the site.

Prestressing steel is sensitive to rusting, notches, kinks and heat. The steel is protected against rusting in transit to the site and, on site, should be suitably stored under cover in dry surroundings.

Research has shown that a light, hard oxide on the tendons is desirable in pre-tensioned members, since it improves the bond characteristics of the tendons. It should also be desirable in bonded, post-tensioned work. However, prestressing steel is more sensitive to corrosion than ordinary reinforcing steel because the individual prestressing wires or strands are small in diameter in comparison to reinforcing bars. Corrosion and, in particular, pitting reduce the cross-sectional area of the tendon by a relatively large amount. Tendons must therefore be checked for indications of pitting corrosion. When this is found, the tendons should be rejected.

For much the same reason, tendons should be checked for notches or kinks. By providing focal points for stress concentrations, they invite stress corrosion, or in severe cases, over-stressing.

Tendons are also susceptible to excessive heat which can destroy or alter the high-tensile

characteristics of the steel. Welding operations should never be carried out on, or adjacent to, prestressing tendons.

Tendons may consist of individual wires, strands, or bars as shown in **Table 6.4**.

Table 6.3 – Meshes Commonly Available in Australia (from Table 7.6(A) of AS/NZS 4671)

Mesh type and reference number	Longitudinal bars		Crossbars		Mass of 6 m x 2.4 m sheet (kg)	Cross-sectional area/m width	
	No. x dia. (mm)	Pitch (mm)	No. x dia. (mm)	Pitch (mm)		Longitudinal bars (mm ² /m)	Cross bars (mm ² /m)
Rectangular							
RL1218	25 x 11.9	100	30 x 7.6	200	157	1,112	227
RL1018	25 x 9.5	100	30 x 7.6	200	109	709	227
RL818	25 x 7.6	100	30 x 7.6	200	79	454	227
Square, with edge side-lapping bars							
SL102	10 x 9.5 + 4 x 6.75	200 100	30 x 9.5	200	80	354	354
SL92	10 x 8.6 + 4 x 6.0	200 100	30 x 8.6	200	66	290	290
SL82	10 x 7.6 + 4 x 5.37	200 100	30 x 7.6	200	52	227	227
SL72	10 x 6.75 + 4 x 4.75	200 100	30 x 6.75	200	41	179	179
SL62	10 x 6.0 + 4 x 4.24	200 100	30 x 6.0	200	33	141	141
Square, without edge side-lapping bars							
SL81	25 x 7.6	100	60 x 7.6	100	105	454	454
Trench meshes							
L12TM	N x 11.9	100	N/A	N/A	N/A	1,112	N/A
L11TM	N x 10.7	100	N/A	N/A	N/A	899	N/A
L8TM	N x 7.6	100	N/A	N/A	N/A	454	N/A

NOTE: The edge bar on SL meshes may be replaced by smaller diameter edge bars of equal or greater total cross-sectional area provided the smaller bars meet the minimum ductility requirements of the bar to be replaced.

Prestressing Wire

High tensile steel wire, up to 8 mm in diameter, is most commonly used for the tendons in pre-tensioned concrete. It should comply with the requirements of AS 4672.1 and may be 'as drawn (mill coil)' wire, 'stress relieved' wire or 'quenched and tempered' wire.

Wire diameters are kept small to increase the surface area available for bond, or bond may be improved by rolling small indentations into the wire or by crimping **Figure 6.2**.

Wire is usually supplied on specially wrapped coils. Before unwrapping, the coils should be placed on a purpose-made spindle that has

outside restrainers and a brake to prevent unravelling and crossing of the wire.

Table 6.4 – Tensile Strength of Commonly Used Wire, Strand and Bar

Material type and relevant Standard	Nominal diameter (mm)	Area (mm ²)	Minimum breaking load (kN)	Minimum tensile strength (MPa)
Wire – AS 4672.1	5	19.6	34.7	1,770
	7	38.5	64.3	1,670
	9.5	55.0	102	1,850
7-wire super strand – AS 4672.1	12.7	98.6	184	1,870
	15.2	143	250	1,750
	15.2 EHT	143	261	1,830
Bars – super grade only – AS 4672.1	26	562	579	1,030
	29	693	714	1,030
	32	840	865	1,030
	40	1,232	1,269	1,030

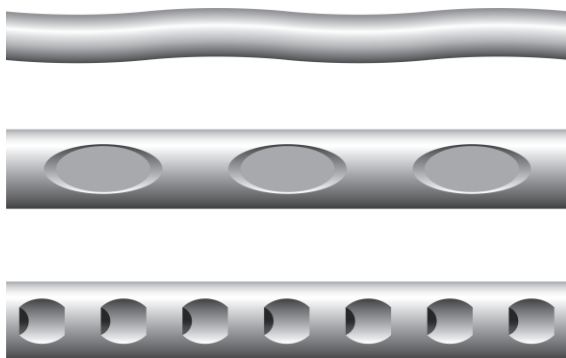

Figure 6.2 – Crimped or Indented Wire

Prestressing Strand

Strand is composed of a central wire tightly enclosed by other wires laid helically around it.

Strands commonly consist of seven wires (7-wire strand) and are normally between 8 mm and 18 mm in diameter. They should comply with the requirements of AS 4672.1. In Australia, the most common strand is the 12.7 mm-diameter 7-wire super-grade stress-relieved low-relaxation strand. Its minimum breaking load is 184 kN at a nominal steel tensile strength of 1,870 MPa.

Strand is supplied on large drums or in large coils with a centre pull to unwind. The same care should be taken when releasing the first section as with wires.

Centre pulling of coils is a more convenient method, provided certain precautions are taken. The first precaution is to prevent the coil expanding, collapsing or tangling. The second precaution is to ensure the lay of the strand is tightened as it is pulled off the coil. Strand acquires a twist as each loop is removed, and this twist should be directed in such a way as to tighten the lay. Manufacturers should be consulted for the direction of the lay (Figure 6.3).

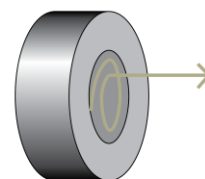
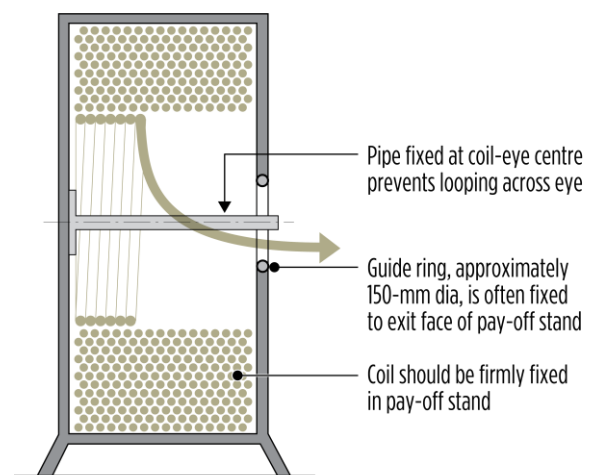

LEFT HAND LAY

Loop travels counter-clockwise round the eye of the coil

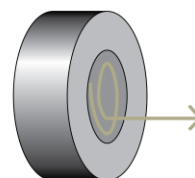

RIGHT HAND LAY

Loop travels clockwise round the eye of the coil

Figure 6.3 – Centre Pulling of Wire and Strand

Prestressing Bars

Prestressing bars should comply with AS 4672.1. They are used to provide large forces in restricted areas, being relatively easy

to handle and simple to couple with threaded connections. Bars are suited to short length stressing or where restressing or coupling is required.

3.2 IDENTIFICATION OF PRESTRESSING WIRE, STRAND AND BARS

The designation of prestressing steel is identified by an alphanumeric sequence providing information on the applicable standard (AS/NZS 4672.1), nominal diameter, tensile strength and other properties such as:

- Type of strand or bar (e.g. '7 wire ordinary' or 'bar');
- Wire surface (a letter indicating surface features such as 'P' for plain or 'R' for ribbed);
- Treatment (such as 'S' for stress relieved);
- Relaxation class ('Relax 1' or 'Relax 2');
- Ductility class (for quenched and tempered wires);
- Direction of Lay (Left or Right) – see **Figure 6.3**.

For example, a common 7 wire strand with 12.7 mm diameter is designated as follows:

AS/NZS 4672.1-7 wire ordinary-12.7-1860-Relax 1-Right

4 OTHER PROPERTIES OF REINFORCEMENT, PRESTRESSING WIRE, STRAND AND BARS

4.1 ELASTIC MODULUS

The elastic modulus for all steel reinforcement is assumed to be 200×10^3 MPa for design of reinforced concrete using the Australian design Standards and does not significantly vary with strength grade of the steel.

For prestressing tendons and hot rolled high tensile steel alloy bars the elastic modulus is estimated to range between 195×10^3 MPa and 215×10^3 MPa. Prestressing strand is

estimated to have an elastic modulus between 195×10^3 MPa and 205×10^3 MPa.

4.2 COEFFICIENT OF THERMAL EXPANSION

The coefficient of thermal expansion of steel reinforcement is similar to that of concrete. In the Australian design Standards, a value of $12 \times 10^{-6} / ^\circ\text{C}$ is used for normal steel reinforcement. For stainless steel reinforcement this may vary from $13 \times 10^{-6} / ^\circ\text{C}$ to $16 \times 10^{-6} / ^\circ\text{C}$ depending on the quality of steel as designated in BS 6744 and its reference EN 10088-1.

5 REFERENCES

- 1) AS 3600 – *Concrete structures*
- 2) AS 5100.5 – *Bridge design, Part 5: Concrete*
- 3) AS/NZS 4671 – *Steel for the reinforcement of concrete*
- 4) AS/NZS 4672.1 – *Steel prestressing materials, Part 1: General requirements*
- 5) AS 1310 – *Steel wire for tendons in prestressed concrete*
- 6) AS 1311 – *Steel tendons for prestressed concrete, 7-wire stress-relieved steel strand for tendons in prestressed concrete*
- 7) AS/NZS 1554 – *Structural steel welding (series of Standards)*
- 8) AS 1554.3 – *Structural steel welding, Part 3: Welding of reinforcing steel*
- 9) BS 6744 – *Stainless steel bars, Reinforcement of concrete, Requirements and test methods*
- 10) EN 10088-1 – *Stainless steels, List of stainless steels*

CONTENTS

1. OUTLINE	2
2. FIBRE TYPES AND SPECIFICATION.....	2
2.1 GENERAL.....	2
2.2 STEEL FIBRES.....	2
2.3 SYNTHETIC FIBRES	4
2.4 OTHER FIBRE TYPES.....	6
3. REFERENCES.....	8

1. OUTLINE

Another form of reinforcement of concrete is available with the use of various types of fibres.

The more common forms of fibres currently available are discussed in this section but it must be noted that new forms of fibres, including variations from material used to manufacture the fibre, shape and size are being developed all the time.

The common broad material types used in fibres are discussed in this section including steel, various types of synthetic, glass, carbon and some natural fibres. Each of these materials will enhance concrete properties in various ways that are briefly discussed.

There are no current Australian Standards covering the specification of the fibre itself and so there is a reliance on reference to international standards. AS 3600 and AS 5100.5 do reference some aspects of the use of fibres in concrete but their scope is limited at present.

2. FIBRE TYPES AND SPECIFICATION

2.1 GENERAL

The history of the use of fibres to provide benefits to mortars or concrete dates back about 3,500 years with earliest use of various natural fibres to reinforce mud bricks in the Middle East. Asbestos fibres have been used in

fibre/cement products for the last 100 years and cellulose fibres for the last 60 or more years. In the last 50 years steel fibres, synthetic fibres, carbon fibres, natural fibres and glass fibres have been used to improve concrete properties.

The properties of concrete that are being enhanced, to varying degrees, by different types of fibre include:

- Improved concrete plastic state cracking performance;
- Improved tensile or flexural strength or post cracking strength performance;
- Improved impact strength or toughness of a concrete structure;
- Cracking control by improved post-cracking ductility;
- Improved concrete durability in certain environments.

Most of these reasons for using fibres have already been discussed in Part I of this Guide and will not be covered in this section. This section will cover the types of fibres most commonly used in Australian concrete and where possible provide guidance on their specification for use in concrete.

2.2 STEEL FIBRES

Steel fibres are commonly described by Shape, Aspect Ratio, Length and Tensile Strength.

The aspect ratio of a fibre is defined as the length of the fibre divided by the average cross section diameter of the fibre.

Each fibre shape and length will have a maximum volume of fibre that can be added per cubic metre of concrete. In the case of steel fibres used in concrete containing normal quantities of coarse aggregate in the mix design, it is rare that steel fibre dose rate can exceed 1% by volume (approximately 80 kg per m³). This is largely as a result of the effect of interference between fibres and coarse aggregate in the concrete mix and its impact on concrete mix workability. The typical doses of steel fibres range from 0.3% to 1% of the concrete volume. Higher doses of fibres may be

used in some specialised concrete with little or no coarse aggregate.

Typical Properties of Steel Fibres

The steel fibre tensile strength, aspect ratio, length, shape and dose rate in the concrete mix all impact on the final hardened properties of concrete that contains these fibres as noted in Part I of this Guide. These and other properties of steel fibres are discussed in the following.

Tensile Strength and Elastic Modulus of Steel Fibres

Steel fibre tensile strength typically ranges between 800 MPa and 2,000 MPa. Each fibre type and source have their own design tensile strength. Measurement of steel fibre tensile strength is generally carried out in accordance with Euro or ASTM standards (e.g. ASTM A820 or EN 14889-1).

The elastic modulus of steel fibres is normally reported as approximately 200 GPa as per other normal forms of steel reinforcement. The failure strain of steel fibres varies with type of steel fibre but generally ranges from 3% to 5% extension.

Common Shapes and Aspect Ratios of Steel Fibres

There are many different shapes and aspect ratios associated with steel fibres. As a general rule it is rare for a steel fibre to have an aspect ratio greater than 80 where the dose rate of fibres is as high as 1% by volume of concrete but for lower dose rates the higher aspect ratios may be used. The commonly used steel fibres have aspect ratios between 30 and 80.

Some common shapes of steel fibres are indicated in **Figure 7.1**.

Specification of Steel Fibres

ASTM A820 or EN 14889-1 can be used to specify steel fibres.

ASTM A820 identifies five basic types of steel fibres based on their manufacture method:

- Type I, cold-drawn wire;
- Type II, cut sheet;
- Type III, melt-extracted;
- Type IV, mill cut;
- Type V, modified cold-drawn wire.

Each type of fibre can be either straight or deformed.

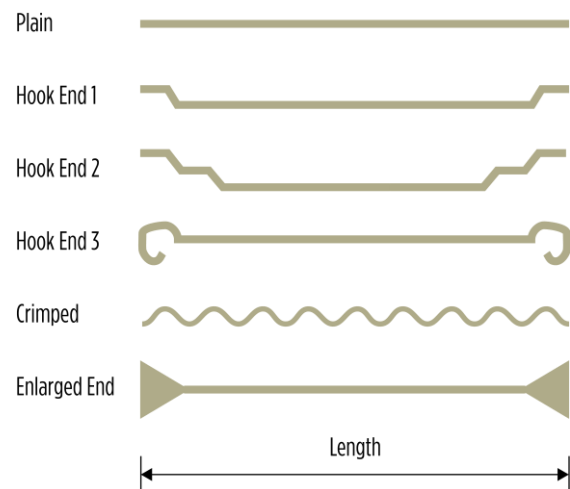

Figure 7.1 – Some Common Steel Fibre Shapes

Using this standard for steel fibres requires the fibres to be assessed for:

- Tensile strength (average tensile strength to exceed 345 MPa);
- Allowable variation in fibre dimensions and resulting aspect ratio;
- Bending test (fibres bent around a 3.2 mm pin to an angle of 90° must not break in more than 10% of fibres in the sample).

EN 14889-1 'Fibres for concrete, Part 1: Steel fibres - Definitions, specifications and conformity' classifies steel fibres into five groups in a similar manner as ASTM A820. In the case of EN 14889-1 it has the following groups:

- Group I – Cold-drawn wire;
- Group II – Cut sheet;
- Group III – Melt extracted;
- Group IV – Shaved cold drawn wire;
- Group V – Milled from blocks.

For each group there are further characterisations by properties such as:

- Cross-section: Round, flat, crescent etc.;
- Deformations: Straight, wavy, end hook etc.;
- Length:19-60 mm;
- Aspect Ratio (length/diameter): 30-100;

- Tensile strength.....345-1,700 N/mm²;
- Young's modulus.....205 kN/mm².

The properties of the fibres covered by EN 14889-1 include a requirement for the fibre supplier to advise the dose rate of fibres in kg/m³ to achieve a residual flexural strength of 1.5 MPa at CMOD = 0.5 mm and/or a residual flexural strength of 1 MPa at CMOD = 3.5 mm when tested on a standard concrete mixture in accordance with the standard beam test (EN 14651 'Test Method for Metallic Fibre Concrete - Measuring the Flexural Tensile Strength').

The CMOD or 'crack mouth opening displacement' has been mentioned previously in Part I of the Guide.

2.3 SYNTHETIC FIBRES

In Part I of the Guide it was noted that there are a number of materials used in producing fibres. There is also a large variety of dimensions and forms of synthetic fibres.

The key specifications for synthetic fibres used in concrete are:

- ASTM C1116 – *Standard Specification for Fiber -Reinforced Concrete*;
- EN 14889-2 – *Fibres for concrete, Part 2: Polymer fibres - Definitions, specifications and conformity*.

ASTM C1116 has relatively little range in definition/specification for synthetic fibres and relies on the impact of fibres on the properties of concrete containing a specific fibre. The classification for synthetic fibres is 'Type III – Synthetic Fiber Reinforced Concrete'. Properties of the fibre that are of concern are:

- Impact of concrete and admixtures on long term deterioration of the fibres (impact of moisture and alkalis in concrete);
- Impact of fibres on concrete consistency and water requirement;
- Impact of fibres on air entrainment of concrete;

- Impact of fibres on flexural tensile strength of the concrete tested in accordance with ASTM C1609.

The ASTM C1116 standard does note that fibres composed of polypropylene, polyethylene or nylon have demonstrated a suitable degree of durability in concrete.

EN 14889-2 provides more detail regarding the specification of the fibres themselves and identifies three general polymer (synthetic) fibre categories:

- Class 1a – Micro fibres – Monofilament with diameter less than 0.30 mm;
- Class 1b – Micro fibres – Fibrillated with diameter less than 0.30 mm;
- Class 2 – Macro fibres – Diameter greater than 0.30 mm.

EN 14889-2 defines 'polymer' as being composed of any of the following general synthetic materials or combinations of these:

- Polypropylene;
- Polyethylene;
- Polyester;
- Nylon;
- Polyvinyl alcohol (PVA);
- Poly-acrylic;
- Aramids.

EN 14889-2 also provides guidance on compliance of all classes of polymer fibres. The following set of properties can be specified:

- Class;
- Polymer type;
- Fibre shape and Aspect Ratio;
- Fibre length;
- Equivalent diameter of fibre;
- Linear density (of mono filament yarn) or density;
- Fibre shape;
- Tensile strength of fibre (largely Class 2);
- Tenacity class of fibre (Class 1a and 1b only);
- Modulus of elasticity of fibres.
- Melting point and point of ignition of fibres;
- Effect of fibre on consistency of concrete;
- Effect of fibre on strength of concrete.

Testing for these properties are generally specified using a relevant EN or ISO standard test method.

Typical Properties of Synthetic Fibres

Each type and class of synthetic fibre will have its own characteristic properties, and these may vary a little between different suppliers. The EN 14889-2 standard requires the supplier to verify compliance to the Standard as required

for each fibre class as a degree of control over specified properties. For testing of fibres in concrete a standard concrete mixture is used in accordance with EN 14845-1. The testing of the effect of fibres on the standard concrete properties are carried out in accordance with EN 14845-2.

Some typical properties of fibres of differing types are provided in **Table 7.1**.

Table 7.1 – Typical Synthetic Fibre Properties (Class based on EN 14889-2)

Fibre Type & Class	Density (gm/cm³)	Diameter (mm)	Elastic Modulus (GPa)	Tensile Strength (MPa)
Polypropylene – Class 1a	0.90 – 0.91	0.015 – 0.100	2 – 5	150 – 400
Polypropylene – Class 1b	0.90 – 0.91	0.030 – 0.100	4 – 5	300 – 500
Polyolefin – Class 2	0.91 – 0.97	0.8 – 1.1	5 – 14	470 – 690
Polyethylene HD – Class 2	0.96	0.9	5	200
Polyethylene HD – Class 1a	0.96	0.020 – 0.050	10 – 30	>400
PVA – Class 1a	1.30	0.003 – 0.015	12 – 40	700 – 1,500
Nylon – Class 1a	1.15	0.009 – 0.200	2 – 4	170 – 690
Aramid – Class 1a	1.20 – 1.45	0.010 – 0.015	70 – 130	2,900 – 3,500

The required synthetic fibre properties will vary between the various classes of fibre and this is discussed in regard to critical properties for its likely end use in the following.

Specified Properties for Class 1a Synthetic Fibres

Smaller diameter Monofilaments are most likely specified for use in structures where some of the following properties of concrete are expected to be improved:

- Reduced permeability;
- Increased impact resistance;
- Some reduction of spalling of concrete in a fire;
- Reduction in concrete plastic cracking.

The properties that may be more critical for specification of these fibres will most likely include:

- Fibre type and Class;
- Fibre length;
- Equivalent diameter of fibre;
- Tensile strength of fibre;
- Effect on consistency of plastic concrete at specified dosage.

Depending on the fibre use the fibre may also need to be assessed for the following:

- Plastic shrinkage reduction (e.g. to ASTM C1579);
- Assessment of specified dosage for reduction in spalling of concrete under fire testing using a specified concrete mix

(e.g. EN 1363-1, EN 1363-2 or ASTM E119);

- Testing of the permeability or impact resistance of concrete using test methods relevant to the end use of the concrete.

Specified Properties for Class 1b Synthetic Fibres

Smaller diameter fibrillated fibres are most likely specified for use in structures where some of the following properties of concrete are expected to be improved:

- Reduced permeability;
- Increased impact resistance;
- Reduction in concrete plastic cracking.

The properties that may be more critical for specification of these fibres will most likely include:

- Fibre type and Class;
- Fibre length;
- Equivalent diameter of fibre;
- Tensile strength of fibre;
- Effect on consistency of plastic concrete at specified dosage.

Other properties may be assessed as required and as noted for Class 1a fibres.

Specified Properties for Class 2 Synthetic Fibres

Macro synthetic fibres are most likely specified for use in structures where some of the following properties of concrete are expected to be improved:

- Improved residual tensile strength of hardened concrete;
- Increased impact resistance;
- Improved cracking control in pavements.

The properties that may be more critical for specification of these fibres will most likely include:

- Fibre type and Class;
- Fibre length;
- Equivalent diameter of fibre;
- Fibre shape and Aspect Ratio;
- Tensile strength of fibre;

- Effect on consistency of plastic concrete at specified dosage;
- Effect on strength of a standard concrete at $CMOD = 0.5$ mm and $= 3.5$ mm in accordance with EN 14889-2 or average residual strength (ASTM C1399), flexural toughness (ASTM C1609) and Flexural toughness factor (ASTM C1609) all carried out using the specified concrete mix.

Other properties may be assessed as required.

2.4 OTHER FIBRE TYPES

There are a number of other fibre types that either have more common use in specific concrete mixtures or are less commonly used. Examples of these include the following:

- Alkali resistant glass fibres;
- Basalt fibres;
- Carbon fibres;
- Asbestos fibres;
- Cellulose fibres ;
- Other 'natural' fibres.

Typical properties of some of these fibre types are provided in **Table 7.2**.

Specified Properties for Alkali Resistant Glass Fibres

Glass fibres for concrete have been developing over many years. In the late 1960's it was determined that the formulation of glass fibres needed to be modified to provide a high degree of alkali resistance to prevent the fibres from degrading in the highly alkaline environment of concrete or mortars. The original 'E-Glass' and 'A-Glass' fibre products are not suitable for use in concrete.

Glass fibres are more generally used in the pre-casting of specific types of light weight building and architectural elements in Australian construction.

The commonly specified properties of glass fibres for use in concrete include:

- Type of fibre (Alkali Resistant);
- Length of fibre ;
- Diameter of fibre;

- Density;
- Tensile Strength;
- Strain at failure.

There are no Australian standards providing guidance on glass fibres for use in concrete, but a useful document is provided by the National Precast Concrete Association of Australia 'A Recommended Practice: Design, Manufacture and Installation of Glass Reinforced Concrete (GRC)'. In addition, there are international standards such as ACI 544.1R 'Report on Fibre Reinforced Concrete' along with ASTM C1116, European Standard EN 15422 'Precast concrete products – Specification of glass fibres for reinforcement of mortars and concretes' and EN 1169.

Specified Properties for Carbon, Mineral-Based and Natural Fibres

This group of fibres are less commonly used in Australia and there are no Australian standards providing guidance on any of these.

It will depend on the expected properties of the concrete containing these fibres as to the critical properties of the fibres that will need to be assessed.

AC I544.1R 'Report on Fibre Reinforced Concrete' provides useful information on the likely fibre properties and their use. Guidance on the properties of these fibres and their impact on concrete will need to be provided by the supplier on an individual basis.

Table 7.2 – Typical Properties of Some Other Fibre Types Used in Concrete

Fibre Type	Density (gm/cm³)	Diameter (mm)	Elastic Modulus (GPa)	Tensile Strength (MPa)
A R Glass fibre	2.68 – 2.74	0.013 – 0.020	72 – 74	1,400 – 3,500
Basalt fibres	2.63 – 2.80	0.007 – 0.013	93 – 110	4,100 – 4,840
Carbon fibres	1.16 – 1.95	0.007 – 0.018	30 – 600	600 – 6,000
Asbestos fibres	2.55	0.0002 – 0.030	164	200 – 1,800
Cellulose fibres	1.5	0.020 – 0.120	10 – 50	300 – 1,000

3. REFERENCES

- 1) AS 3600 – *Concrete structures*
- 2) AS 5100.5 – *Australia Bridge design, Part 5: Concrete*
- 3) ACI 544.1R-96 – *Report on Fibre Reinforced Concrete* (American Concrete Institute)
- 4) ASTM A820-16 – *Standard Specification for Steel Fibers for Fiber-Reinforced Concrete*
- 5) ASTM C1116-10 – *Standard Specification for Fiber-Reinforced Concrete*
- 6) ASTM C1399-10 – *Standard Test Method for Obtaining Average Residual-Strength of Fiber-Reinforced Concrete*
- 7) ASTM C1579-13 – *Standard Test Method for Evaluating Plastic Shrinkage Cracking of Restrained Fiber Reinforced Concrete (Using a Steel Form Insert)*
- 8) ASTM C1609-19 – *Standard Test Method for Flexural Performance of Fiber-Reinforced Concrete (Using Beam with Third-Point Loading)*
- 9) ASTM E119-19 – *Standard Test Methods for Fire Tests of Building Construction and Materials*
- 10) EN 1169 – 1999 – *Precast Concrete Products – General Rules for Factory Production Control of Glass-Fibre Reinforced Cement*
- 11) EN 1363-1 – 2012 – *Fire Resistance Tests Part 1: General Requirements*
- 12) EN 1363-2 – 1999 – *Fire Resistance Tests Part 2: Alternative and additional procedures*
- 13) EN 14845-1 – 2007 – *Test Methods for Fibres in Concrete Part 1: Reference Concretes*
- 14) EN 14845-2 – 2006 – *Test Methods for Fibres in Concrete Part 2: Effect on Concrete*
- 15) EN 14889-1 – 2007 – *Fibres for concrete, Part 1: Steel fibres - Definitions, specifications and conformity*
- 16) EN 14889-2 – 2007 – *Fibres for concrete, Part 2: Polymer fibres - Definitions, specifications and conformity*
- 17) EN 15422 – 2008 – *Precast Concrete Products – Specification of Glass Fibres for Reinforcement of Mortars and Concrete*
- 18) National Precast Concrete Association of Australia, 'A Recommended Practice: Design, Manufacture and Installation of Glass Reinforced Concrete (GRC)' (NPCAA – 2006)

GUIDE TO CONCRETE CONSTRUCTION

T41



CEMENT CONCRETE
& AGGREGATES AUSTRALIA

PART III - Concrete Mix Design

CONTENTS

1. OUTLINE	2
2. THE MIX DESIGN PROCESS	2
2.1 GENERAL.....	2
2.2 COMMON MIX SPECIFICATION REQUIREMENTS	2
2.3 MIX DESIGN STEPS	3
2.4 CHARACTERISTIC STRENGTH AND TARGET STRENGTH.....	5
2.5 W/C RATIO AND TARGET STRENGTH.....	6
2.6 ESTIMATING WATER DEMAND	7
2.7 ESTIMATING AIR CONTENT	8
2.8 ESTIMATING THE VOLUME OF A CONCRETE MIX CONSTITUENTS...9	
2.9 BLENDING AGGREGATES	10
3. ASSESSMENT OF A THEORETICAL MIX DESIGN	15
3.1 GENERAL.....	15
3.2 MIX DESIGN ADJUSTMENTS FOR PLASTIC PROPERTIES	16
3.3 MIX DESIGN ADJUSTMENTS FOR HARDENED CONCRETE PROPERTIES.....	17
4. REFERENCES.....	18

1. OUTLINE

The selection of concrete mix constituents and their proportions is commonly referred to as 'Mix Design'. In Part II of this Guide the various constituents of concrete, their properties and their specification have been discussed. In Part IV of this Guide the various specifications for concrete in Australia are discussed and how some of the specifications will have an impact on a suitable concrete mix design for supply to a given structure during construction. In addition, Part VIII of this Guide also discusses the properties of concrete and how specified concrete properties and quality assurance have an influence on the required concrete mix design.

In this part, the process of concrete mix design is outlined and various methods of carrying out mix design are highlighted. The impact on concrete mix design of specified concrete properties, the influence of Australian Standards, constituent material selection and construction methods are each discussed.

2. THE MIX DESIGN PROCESS

2.1 GENERAL

The process of concrete mix design requires two key starting points. The first point is a specified concrete for supply to a given structure. The second point, which may be influenced by the first, is the concrete will be produced from a combination of constituents that will need to be selected prior to a mix design taking place.

The process for mix design is often an iterative one where various concrete mix constituents are assessed through the mix design and testing process in order to determine the most effective constituent combination to achieve the specified properties of the required concrete mix.

In Australia the two key documents used to specify the minimum requirements for concrete used in concrete structures are AS 3600 'Concrete structures' [1] and AS 1379 'Specification and supply of concrete' [2]. The requirements of these Standards are discussed in Part IV of this Guide but it should be pointed out that using AS 1379, a structural designer may choose to specify a Special-Class concrete with requirements that exceed the minimum requirements set out in these Standards.

2.2 COMMON MIX SPECIFICATION REQUIREMENTS

For 'Normal-Class' concrete, as specified in AS 1379, the key properties of the concrete and its constituents are the following:

- Characteristic compressive strength set out in Table 1.1 of AS 1379 (MPa);

- Maximum aggregate size (either of 10 mm, 14 mm or 20 mm);
- Target slump of concrete at delivery (from 20 mm to 120 mm in 10 mm increments);
- Method of placement of concrete into forms (e.g. pumping of concrete, direct feed from delivery vehicle etc.);
- Proportion of air entrainment (as a % of the volume of concrete up to a maximum of 5% if required).

In addition, there are assumed properties for 'Normal-Class' concrete that are set out in AS 1379 including:

- Selection of mix constituents complying with their relevant Australian Standards (set out in Part II of this Guide);
- Specification of Project Assessment testing on site if required;
- A concrete mass per unit volume between 2,100 kg/m³ and 2,800 kg/m³;
- Acid soluble chloride and sulfate contents of concrete in accordance with limits set out in AS 1379;
- Concrete drying shrinkage not greater than 1,000 micro-strain at 56 days;
- The mean compressive strength of concrete at 7-days curing is greater than the values given in Table 1.2 of AS 1379;
- No lightweight aggregate as defined in AS 2758.1;
- Volume of concrete supplied is in accordance with Clause 1.7.2 of AS 1379.

AS 3600 assumes certain durability classifications for concrete are satisfied by achieving a minimum characteristic strength of concrete but the Normal-Class concrete mix design may not meet the AS 3600 durability classifications unless the aggregates used in the concrete mix also comply with AS 2758.1 [3] requirements for the specified durability class of concrete. It is for this reason that concrete designed to meet AS 3600 exposure classifications B2, C1, C2 or U is deemed to be 'Special Class' under AS 1379. Any specification requirements other than those for 'Normal-Class' concrete as defined in the foregoing will indicate the concrete is 'Special Class' as defined in AS 1379 and the specifier

will be responsible for defining the additional or modified requirements as required by AS 1379 clause 1.5.4 and Appendix B.

Some common examples of Special-Class specification include:

- Early strength requirements for concrete (e.g. 32 MPa at 24 hours);
- Lower maximum shrinkage requirements (e.g. 600 micro-strain at 56 days);
- Minimum cement content of a mix (e.g. 32 MPa at 28 days with a minimum cement content of 400 kg/m³);
- Maximum Water/Cement ratio (W/C) requirement (e.g. 32 MPa with maximum W/C ratio of 0.45);
- Specifier details a mix proportion to be used in a mix design;
- Mix to achieve a nominated characteristic flexural tensile strength;
- Mix to have a slump spread of 650 mm.

Each of these Special-Class requirements will most likely prevent a Normal-Class concrete from being used. To comply with AS 3600 minimum strength for durability in exposure classifications B2, C1, C2 or U and with AS 2758.1 aggregate properties for these exposure classifications, the concrete supplier will need to design a Special-Class mix to meet the special requirements. The specifier will also need to be very careful to fully specify all of the requirements in each of the examples of Special-Class concrete as well as a means of assuring compliance of the concrete.

For more information on standards and specification of concrete it is recommended to see Part IV, Section 8 of this Guide as well as the referenced Australian Standards.

2.3 MIX DESIGN STEPS

There are many different mix design methods used. In reality, the number of mix design methods is probably close to the number of 'concrete technologists' working in the concrete construction industry. Some methods are based on computer-based systems and some methods are more manual. All are useful in their own way if they support the user in developing

mix designs in a rapid and accurate way. In this section two of the more manual methods are referred to as they provide a better understanding of the principles involved.

In all methods the process followed should contain the following steps:

1. Analysing the desired outcome from the specifications for the concrete mix;
2. Checking the specifications against the minimum requirements of relevant Standards;
3. Considering the mixing and placing methods;
4. Choosing constituent combinations that will support the desired outcome;
5. Doing a theoretical mix design using a suitable method;
6. Undertaking laboratory trials of the mix and making adjustments to the mix to ensure it meets specified properties;
7. Undertaking field trials and making any required further adjustments to mix design to cope with site requirements.

Some of these steps are an iterative process and may be repeated a number of times to get to the final result. In Step 5 – the mix proportioning aspect of mix design – there is one thing that is common to all mix methods and that is the need to estimate the mix paste content. This involves the estimation of each of the following:

- The water content;
- The binder (cement + SCM) content;
- The entrained air content.

Estimating these three quantities – those that form the paste portion of mix – is normally related to consideration of the specified or inferred strength and durability requirements. These three factors are also influenced by the consistency of the concrete (typically specified by target slump), coarse and fine aggregate selection (type, size and shape) and the admixture selection.

The paste makeup and volume can be estimated using tools derived from past experience using the following steps:

- (a) Use the specified slump and maximum aggregate size of the concrete to estimate the water content of the mix based on suitable charts. Some more computer-based tools use estimation of total mix packing density algorithms to estimate mix water content at a specified consistency and air content;
- (b) From the specified maximum W/C ratio a minimum cement (or cement + SCM) content of the mix can be determined to achieve this W/C ratio;
- (c) From the specified characteristic strength of the concrete the minimum target strength of the concrete can be determined so as to take account of variability in the production and testing processes. From the minimum target strength of the concrete a W/C ratio versus average concrete strength chart for the cement blend used can be used to determine the maximum W/C ratio to achieve the characteristic strength specified. From this maximum W/C ratio a minimum cement (or Cement + SCM) content of the mix can be determined to achieve this W/C ratio;
- (d) The greater cement (or cement + SCM) content as determined in steps (b) and (c) is used as the content for the initial mix design;
- (e) If the mix air content is specified, then this volume of air is used in the mix design. If it is not specified, then the typical air content will be estimated based on maximum aggregate size and admixtures used;
- (f) The volume of paste is now estimated and is simply the volumes of water + cement + SCM + air.

Having estimated the volume of paste, the remaining volume of the mix is entirely composed of coarse and fine aggregates. The general principle is that a unit volume (e.g. 1.00 m³) of concrete is being designed. Based on this, if the paste volume is estimated to be 0.30 m³, then the solid volume of coarse and fine aggregates will be 0.70 m³.

Methods for determining the proportions of individual aggregates vary significantly, and the

proportions can be impacted by the maximum size of aggregate, binder content and specified consistency. This is a more complex part of the mix design process, but the end result is a table of theoretical mix design components for testing, assessment and correction (**Table III.1**).

The following provides further detailed information on methods commonly used in building up the theoretical mix design based on the foregoing.

2.4 CHARACTERISTIC STRENGTH AND TARGET STRENGTH

Compressive strength is one of the most important properties of concrete. A number of other properties of concrete, such as durability, tensile strength, elastic modulus and creep factor are to some degree related to the compressive strength of concrete.

Table III.1 – Example of Theoretical Mix Design Table

Materials	1.0 m ³ Batch Weights
Cement	210 kg
Fly Ash	70 kg
Total Free Water	170 litres
20 mm Aggregate	680 kg
10 mm Aggregate	340 kg
Coarse Sand	530 kg
Fine Sand	300 kg
Air Entraining Admixture	80 mL/m ³
Water Reducing Admixture	400 mL/100 kg cement
Target Entrained Air Content	4% ± tolerance
Target Slump	80 mm ± tolerance

Australian Standards AS 3600 and AS 1379 and most international concrete standards specify a concrete using its 'characteristic compressive strength'. The characteristic strength is defined by a statistical approximation which is stated in these Standards as follows:

'Value of the material strength, as assessed by standard test that is exceeded by 95% of the material'.

This means that at least 95% of all standard compressive strength tests taken on a given mix design concrete will exceed the characteristic compressive strength (assuming that the concrete supplier has a very large number of tests to make that assessment). The reality is that the concrete supplier rarely has such a large number of tests to carry out this assessment and because of this fact AS 1379 provides a range of assessments based on satisfying both supplier risk and consumer risk, using statistical principles to assess smaller numbers of tests for compliance to the requirement for a particular characteristic strength.

More information on this is provided in Part IV, Section 8 of this Guide as well as in AS 1379 and its Supplement 1 document [4].

If the statistical principle applicable to characteristic strength is applied, assuming that the compressive strength test data randomly follows what is called a 'normal distribution', then it is reasonable to assume that the expected average strength of this large number of tests will exceed the characteristic strength ($F'c$) by a factor that is dependent on the variability of the set of tests assessed. This variability factor is calculated using a statistical formula and is generally referred to as the 'standard deviation' (SD) of the test sample population. The general formula relating $F'c$, SD and average strength is simply:

$$F'c = \text{Average Strength} - k \times SD \dots \text{Eq.III.1}$$

In this formula 'k' is a constant that is statistically derived and depends on the number of test samples used to calculate the average

strength and standard deviation. Aspects of these calculations as they relate to AS 1379 are covered in more detail in Part IV, Section 8 and Part VIII, Section 26 of this Guide.

When carrying out a mix design and generally when setting up quality control systems for the compressive strength of concrete, the mix designer uses a strength that is referred to as the 'Target Strength' of the concrete mix being designed or supplied. It is different from both the characteristic strength and the average strength of the test sample population. In general, its value is more an 'intended' average strength for the mix design and in general it will be either equal to or greater than the average compressive strength. To calculate the Target Strength the following simple formula is used:

$$\text{Target strength} \geq F'c + (k \times SD) \dots \text{Eq.III.2}$$

From this formula it can be seen that provided a reasonable value of SD is made and that $F'c$ is specified then an estimate of Target Strength can be made. For the purpose of mix design and using the definition of characteristic strength defined in AS 3600 and AS 1379 (assuming a very large population of test results) it can be shown that the constant $k = 1.65$ (approximately).

The SD of a concrete mix is a measure of variability of the concrete compressive strength test results and is dependent on both materials and manufacturing variables, including:

- Variability in cement and SCM quality;
- Variability in coarse and fine aggregate quality;
- Variability in admixture quality;
- Variability of batching accuracy at the concrete manufacture facility;
- Impact of varying ambient temperatures during and after manufacture of the concrete mix;
- Variability in mixing of the concrete mix during production;
- Variability in time from batching to placement and testing of the concrete mix;

- Variability in the testing procedures used to assess the concrete over time;
- The strength of the concrete mix being assessed.

A concrete supplier with a well-controlled quality management system will be able to actively reduce the concrete mix supply variability and SD but if no reliable data is available then **Table III.2** provides some guidance of SD values that can be used in a preliminary mix design.

Using data from **Table III.2** for a concrete with specified characteristic strength of 40 MPa, the minimum target strength can be calculated using **Eq.III.2** as being approximately 46.4 MPa.

Table III.2 – Approximate Standard Deviation for Mix Design

Standard Deviations for concrete where no data is available	
Characteristic Strength (MPa)	Approximate Standard Deviation (MPa)
20	3.0
25	3.3
32	3.6
40	3.9
50	4.2

2.5 W/C RATIO AND TARGET STRENGTH

In 1919, concrete technologist and researcher Duff Abrams noted a relationship between the average strength of a concrete mixture and its water/cement ratio and he created a mathematical formula to describe the relationship. In general, this relationship is dependent on the particular cement and aggregate properties but indicates that for a particular set of materials the higher the W/C ratio is, then the lower the strength will be. Since Abrams there have been numerous researchers on this topic and more detailed formulae have been produced. No single

formula will work universally for all materials as variation in constituents will require a variation in the relationship.

Cement and concrete suppliers will develop their own formulae for specific blends of materials. Some typical examples are given in graphs for two types of cement blends in **Figure III.1** and **Figure III.2**. While characteristic strength in AS 3600 normally refers to the 28-day strength, these graphs do demonstrate the range of average strengths at other ages that may be specified for mix designs. In some cases, the early age strength is specified as a characteristic strength. In this case a suitable Target Strength at the early age must be estimated in the same way as would be done for the standard 28-day characteristic strength.

In the mix design process, a characteristic compressive strength is specified at 28 days. The Target Strength of the concrete is estimated as noted in sub-section 2.4 and, using the Target Strength and a formula (such as that graphed in **Figures III.1** and **III.2**), the average W/C ratio can be estimated for the mix design.

COMPRESSIVE STRENGTH Vs. W/C RATIO - GP CEMENT

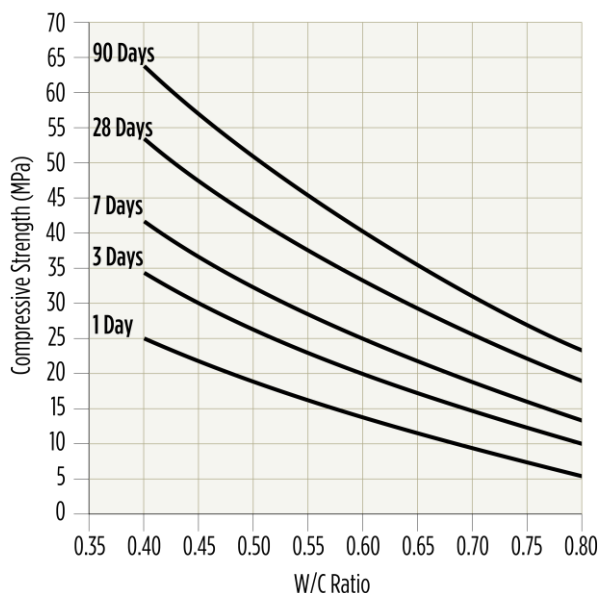

Figure III.1 – W/C Vs. Strength Curves for GP Cement

COMPRESSIVE STRENGTH Vs. W/C RATIO - 75% GP CEMENT + 25% FLYASH

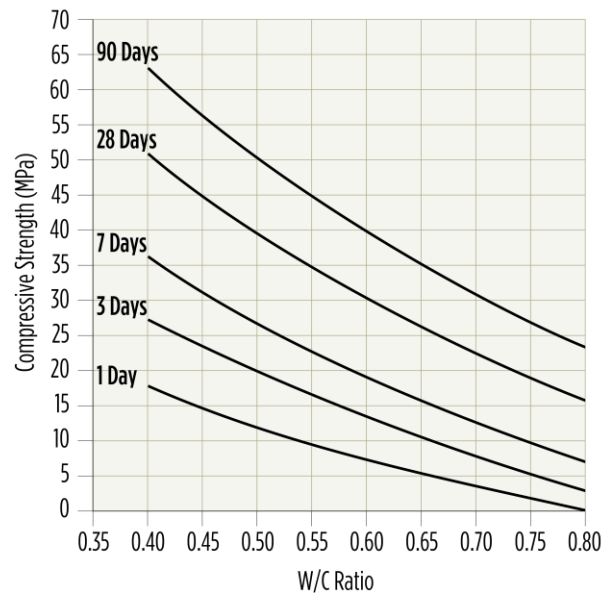

Figure III.2 – W/C Vs. Strength Curves for a Blend of 75% GP Cement with 25% Fly Ash

2.6 ESTIMATING WATER DEMAND

The total water content of any concrete mix is affected by any (or all) of the following factors:

- Consistency or slump of concrete;
- The maximum aggregate size of the concrete mix;
- The properties of the coarse and fine aggregate that affect the packing of aggregate (e.g. shape and surface texture);
- Silt and clay fines in the fine and coarse aggregate;
- Admixtures used in the concrete;
- The type of cement and SCM used;
- The air content of the concrete mix;
- The volume of cement plus SCM's in the mix;
- The ambient and concrete temperature as well as the time of the concrete delivery from mixing to delivery on site.

When designing a concrete mix, it is necessary to take account of all of these factors.

The 'water content' in concrete is normally calculated as the volume of water added to the concrete plus the water contained in the coarse and fine aggregates in excess of that required

to produce a saturated surface dry (SSD) condition plus the water content in the admixtures used. This quantity of water is more correctly referred to as 'Total Mix Water' and is the volume of water used to calculate W/C ratio.

ACI 211.1 [4] provides some useful approximate estimates of the total water content of concrete for differing maximum aggregate sizes and slumps. A selection of this information is reprinted in **Table III.3**.

As can be seen in **Table III.3**, the total water content of concrete is significantly reduced by increasing the maximum aggregate size or reducing the concrete slump. While ACI 211.1 does consider the impact of air entrainment on the total water content it does assume a mix design in accordance with this Standard but does not allow for the effects of admixtures, significant variance in cement content or the properties of the aggregates.

Air entrained in concrete can partially replace some of the volume of total water at the same consistency. ACI 211.1 does discuss this impact and it is discussed further in sub-section 2.7.

Table III.3 – Estimate of Water Content of Concrete Mixes with Different Maximum Aggregate Size & Slump (based on ACI 211.1)

Max. aggregate size (mm)	Water content of non-air entrained concrete		
	Average slump (mm)		
	40 mm	90 mm	160 mm
9.5	207	228	243
12.5	199	216	228
19	190	205	216
25	179	181	202
37.5	166	169	190
50	154	160	178
75	130	145	160

Admixtures used in concrete may have a significant effect on the mix design total water content. Admixtures are discussed in detail in Part II, Section 5 of this Guide. In the case of

water-reducing, mid-range water-reducing and high-range water-reducing admixtures the mix total water content can be reduced by between 5% and 25% depending on the specific admixture or admixture combination used. Admixture suppliers can provide data on the effectiveness of their products.

For example, a mix design using 19 mm maximum sized aggregate and a 90 mm target slump will have a design water content of approximately 205 Litres/m³ without admixtures of any type (refer to **Table III.3**). If a mid-range water reducing admixture with a demonstrated water reducing ability of 10% is used in the mix, then approximately 20 Litre/m³ of water can be taken out of this mix giving a revised water content of 185 Litres/m³.

2.7 ESTIMATING AIR CONTENT

Air occurs in concrete in two forms:

- Naturally entrapped air (typically ranging from 0.2% to 3.0% in general);
- Specifically, entrained air produced by the actions of admixtures including air entraining admixtures (AEA).

Both forms of air are part of concrete mix volume but may have differing impacts on the concrete workability and consistency as well as having different air bubble sizes.

Entrained air will generally have the following properties in a plastic concrete mix:

- It may improve the workability of concrete at the same consistency;
- It can replace an amount of the design water in the plastic concrete mix at the same consistency;
- It increases the volume (yield) of the concrete mix.

In the concrete hardened state entrained air is most useful in protecting against freeze-thaw damage in exposed concrete structures. AS 3600 specifies entrained air contents (that vary with maximum sized aggregates used) that are necessary to provide a level of freeze-thaw durability. These percentages of entrained air are:

- For 10 mm to 20 mm maximum sized aggregate – use between 4% and 8% entrained air;
- For 40 mm maximum sized aggregate – use between 3% and 6% entrained air.

ACI 211.1 also gives similar advice for freeze-thaw protection but notes that the design air content, for what AS 1379 describes as Normal-Class concrete, can benefit workability by adding some air entrainment over the naturally entrapped air content. This gives the mix designer the ability to selectively design for extra air to a mix where lower cement contents are used. The ACI 211.1 recommendations are summarised in **Table III.4**.

The effectiveness of air entrainment on reducing the total water content of concrete varies with the amount of air entrained (as opposed to entrapped air). In the design air contents suggested by ACI 211.1 in **Table III.4**, it can be seen that for each maximum aggregate size the added entrained air for improved workability is around 1.5% air. In **Table III.5** the likely water reduction for 1.5% and 3.0% added entrained air is estimated for a range of W/C ratio concrete mixes.

Table II.4 – Design Air Contents for Normal Concrete

ACI 211.1 Recommended total Air Content		
Maximum Aggregate Size (mm)	Design Entrapped Air (%)	Total Air Content for improved Workability (%)
9.5	3.0	4.5
12.5	2.5	4.0
19	2.0	3.5
25	1.5	3.0
37.5	1.0	2.5
50	0.5	2.0
75	0.3	1.5

From **Table III.5** the estimate for the design total water reduction due to entraining 3.0% air in a mix with a calculated design W/C ratio of 0.50 would be 9 litres per m³ less than that estimated in using **Table III.3** and before the

impacts of any other admixtures on total water content reduction are accounted for.

Table III.5 – Impact of Entrained Air on Mix Total Water

Water Reduction for Design Air Content		
Concrete W/C Ratio	1.5% Entrained Air (Litre/m³)	3.0% Entrained Air (Litre/m³)
0.80	15	25
0.70	12	20
0.60	9	15
0.50	5	9
0.40	2	4

2.8 ESTIMATING THE VOLUME OF A CONCRETE MIX CONSTITUENTS

A key principle in mix design is that the aim of combining a set of concrete ingredients is to produce a total volume of concrete equal to 1.000 m³ as noted in sub-section 2.3. The addition of the volume of all constituents added to concrete in a concrete mix design should equal 1.000 m³ if correctly designed. The calculation of the volume of each constituent group in the concrete mix is normally estimated by slightly varying rules. In terms of calculation method, the groups of constituents with common methods of estimating their volume are:

- Cement and SCMs;
- Coarse and fine aggregates;
- Water and liquid admixtures;
- Dry additives including fibres.

The method for calculating the volume of each of these four groups is discussed in the following sub-sections.

Cement and SCM Volumes

Cement and SCM's are normally produced in the form of essentially dry powders. Their solid volume in the concrete mix is estimated by dividing their proposed dry mass (normally in

kg) by the tested value of the individual cement or SCM particle density (in kg/m³).

The particle density of this group of materials is commonly provided by the supplier in the form of a 'specific gravity' or SG which is the particle density relative to water. For example, GP cement in Australia will typically have an SG of between 3.12 and 3.16 and a value of 3.15 is used in mix design. To convert the SG to kg/m³ is simply multiply the SG by 1,000 (the density of water at 23°C). In this case the particle density of the GP Cement becomes 3,150 kg/m³. So, where a mix contains (for example) 350 kg of GP Cement, its volume in the concrete mix equals $350/3,150 = 0.111 \text{ m}^3$.

SCM's such as fly ash, ground granulated blast furnace slag or silica fume generally have lower particle densities than cement and the supplier will be able to provide the mix designer with the SG or particle density values specific to each particular product.

Coarse and Fine Aggregate Volumes

Aggregates are generally separated into the specific sizes supplied. A concrete mix may, for example, contain 20 mm aggregate, 10 mm aggregate, manufactured coarse sand and fine natural sand. Each of these four aggregate constituents have in common the fact that they will absorb water and are generally designed in the concrete mix in saturated surface dry ('SSD') condition. When estimating each constituent's volume in the concrete mix the mass of the aggregate is estimated in SSD condition and the volume estimated by dividing the SSD Mass of aggregate by the SSD Particle Density of the aggregate.

For example, consider a concrete mix contains 750 kg of SSD 20 mm Limestone aggregate. This limestone aggregate has an SSD particle density of 2,700 kg/m³ so the volume of 20 mm Limestone in the mix equals $750/2,700 = 0.278 \text{ m}^3$.

Water and Liquid Admixture Volumes

Water is generally measured into concrete in litres or kg (1 litre of water has a mass of approximately 1 kg) depending on the method of batching in a concrete plant. One cubic metre of water is 1,000 litres so if 200 litres of water is

added to a concrete mix then its volume is $200/100 = 0.200 \text{ m}^3$. Water in concrete includes water contained in aggregates in excess of SSD condition. When carrying out batching of concrete aggregates that are not SSD condition, then the net excess water above or below SSD condition needs to be added into the total water and its volume estimated.

Liquid admixtures are either weighed into concrete or more commonly measured by volume. Admixtures are commonly batched as a proportion of the concrete mix cement and SCM mass (mL per 100 kg of binder) or by volume per cubic metre of concrete (mL or litres per m³ of concrete). Admixture suppliers provide information on the density or SG of specific admixtures so their volume is simply calculated if batched by mass (e.g. if an admixture is batched as 400 gm per 100 kg of cement and its SG is 1.12 then simply dividing $400 \text{ by } 1.12 = 357 \text{ mL per } 100 \text{ kg of cement}$).

Admixtures are generally (but not always) a relatively small volume in the concrete mix but should not be ignored in calculations.

Dry Additives and Fibre Volumes

The suppliers of these products generally pre-package these products into pre-weighed packages suitable for batching and can provide details of the SG or particle density of the specific products.

The same procedure will be followed for estimating their volume as is used for cement and SCM materials (i.e. the materials are assumed to be essentially dry and their dry particle density is used to calculate the volume for a specific mass of product dosed).

2.9 BLENDING AGGREGATES

The stage in mix design where aggregates are blended to provide an optimal proportioning is where there are real differences in the many manual mix design methods used. In this section the ACI 211.1 method and the British method developed by the Road Research Laboratory (Road Note No. 4 '*Design of concrete mixes*') [5] are discussed as they take

differing but workable methods to produce a preliminary mix design.

In the previous sections methods for calculating the paste content of a concrete mix design have been discussed along with some methods of estimating the mass and volume of the individual components of a concrete paste. If the total volume of paste plus any additional solid additives was, for example, 0.300 m³ then the remaining volume in a 1.000 m³ concrete mix will be composed of aggregates with a volume of 0.700 m³ (i.e. 1.000 – 0.300).

Both methods for blending coarse and fine aggregates discussed in this section are aimed at producing a preliminary concrete mix design with suitable workability, which requires an understanding of three of the standard aggregate tests:

- The particle size distribution or ‘grading’ of each individual coarse and fine aggregate as well as the ‘combined grading’ of the blends of coarse and fine aggregates;
- The particle density and water absorption of each of the individual coarse and fine aggregates;
- The bulk density of oven dry aggregate for each of the individual coarse and fine aggregate used as well as for blends of coarse or fine aggregates.

These three aggregate properties have been discussed in Part II, Section 3 of this Guide.

The two methods of blending aggregates are discussed in the following sub sections.

The ACI 211.1 Method

In this method, the ACI have recognised two aspects that are apparent from particle packing analysis. The first aspect is that the larger the maximum size aggregate used, the lower the proportion of fine aggregate that will be needed to produce an optimal blend in terms of particle packing. The second aspect is that the finer the fine aggregate is, the greater the portion of coarse aggregate will be needed to produce a similar workability as it reduces the spacing required between coarse aggregate particles in the concrete mix.

As provided in **Table III.6**, the basis of this design is to firstly select a maximum size of aggregate used, and (a) if the aggregate needs to be blended with a smaller size aggregate then an optimal blended grading of the aggregates is determined by achieving a blend that complies with the ‘maximum aggregate size to 4.75 mm’ sieve grading in ASTM C33 [8] which is similar to those for Nominal size ‘graded aggregates’ in AS 2758.1 (and repeated in Part II, Section 3 of this Guide), and (b) the blended aggregate should be assessed for oven dry, compacted bulk density (‘dry rodded’ as per ASTM C29 [7], which is similar to Australian Standard AS 1141.4 [6] in oven dry and compacted condition).

Table III.6 – Volume of Coarse Aggregate per Unit Volume of Concrete (SI units) (replication of ACI 211.1 – Table A1.5.3.3)

Nominal maximum size of aggregate (mm)	Volume of dry-rodded coarse aggregate* per unit volume of concrete for different Fineness Moduli** of fine aggregate			
	2.40	2.60	2.80	3.00
9.5	0.50	0.48	0.46	0.44
12.5	0.59	0.57	0.55	0.53
19	0.66	0.64	0.62	0.60
25	0.71	0.69	0.67	0.65
37.5	0.75	0.73	0.71	0.69
50	0.78	0.76	0.74	0.72
75	0.82	0.80	0.78	0.76
150	0.87	0.85	0.83	0.81

NOTE:

**Volumes are based on aggregates in dry-rodded condition as described in ASTM C 29. These volumes are selected from empirical relationships to produce concrete with a degree of workability suitable for usual reinforced construction. For less workable concrete such as required for concrete pavement construction they may be increased about 10%. For more workable concrete, such as may sometimes be required when placement is to be by pumping, they may be reduced up to 10%.*

***See ASTM Method 136 for calculation of Fineness Modulus.*

If more than one fine aggregate is being used then either (a) a suitable blend of fine aggregates is selected to achieve a Fineness Modulus between 2.4 and 3.0 or (b) a combined grading is selected to meet the grading requirements of ASTM C33 [8].

[NOTE: The Fineness Modulus of sand is simply the percentage retained on consecutive sieve sizes (0.150 mm, 0.300 mm, 0.600 mm, 1.18 mm, 2.36 mm and 4.75 mm) added together and divided by 100 (see **Table III.7** for an example)].

Table III.7 – Fineness Modulus Calculation Example

Calculating Fineness Modulus of Sand			
Sieve Size (mm)	Passing Sieve Size (%)	Retained Sieve Size (%)	Fineness Modulus Calculation
9.5	100	0	0
4.75	100	0	0
2.36	95	5	0.05
1.18	75	25	0.25
0.600	45	55	0.55
0.300	30	70	0.70
0.150	8	92	0.92
0.075	4.5	95.5	N.A.
TOTAL FINENESS MODULUS			2.47

It should be noted that the range of ASTM C33 particle sizes and related Fineness Moduli of sands in concrete for the USA are generally slightly coarser than those generally available in Australia for reasons of different climate and geology, but in most cases a blend of sands with a fineness modulus greater than 2.40 can be achieved.

When calculating the effect of blending two or more aggregates to assess the grading of the blend it is simply done by multiplying each aggregate's grading percentage passing for each individual sieve size by the percentage of that aggregate in the blend. This calculation is best demonstrated in **Table III.8**. For example (from **Table III.8**) at the 13.2 mm sieve:

- 60% of 35% = 21% contribution to the blend for Aggregate A;
- 40% of 100% = 40% contribution to the blend for Aggregate B;
- The total of these two contributions is 61% passing the 13.2 mm sieve for the 60% A + 40% B blend.

Table III.8 – Theoretical Grading of the Blend of Two Aggregates

Calculating Blended Aggregate Grading			
Sieve Size (mm)	Grading Aggregate A (%)	Grading Aggregate B (%)	60% A + 40% B Calculation
26.5	100	100	100
19.0	95	100	97
13.2	35	100	61
9.5	10	85	40
4.75	2	8	4
2.36	1	2	1
1.18	0	0	0

Using **Table III.6** is best demonstrated with an example:

- Assuming that aggregate A and B in the **Table III.8** example are to be used in a concrete mix design and that the 60% Aggregate A + 40% Aggregate B blend has been assessed as having the following properties:
 - Particle size distribution of the blend as noted in **Table III.8**;
 - SSD Particle density of 2,700 kg/m³ and water absorption of 1.0%;
 - Oven Dry compacted bulk density of 1,520 kg/m³.
- In addition, it is to be blended into a concrete mix design with the sand used as an example in **Table III.7** which has the following properties:
 - Particle size distribution and Fineness Modulus as noted in **Table III.7**;
 - SSD Particle density of 2,550 kg/m³ and water absorption of 2.0%.

- Then from **Table III.6** it can be estimated that the quantity of coarse aggregate blend in the concrete mix for a 19 mm nominal size aggregate with sand of FM = 2.47 is approximately 0.65 m³ of compacted, oven dry aggregate per m³ of concrete;
- So, the oven dry coarse aggregate blend is calculated by multiplying the bulk density (1,520 kg/m³) by 0.65 = 988 kg of dry blended coarse aggregate per m³ of concrete;
- This is converted to SSD condition by adding in the water absorbed (i.e. 1% of 988 kg = 10 kg), so the mass of SSD coarse aggregate in the concrete mix is equal to 988 kg + 10 kg = 998 kg of blended coarse aggregate;
- Based on the blend ratio nominated in **Table III.8** this calculates out at 60% of SSD Aggregate A = 599 kg and 40% of SSD Aggregate B = 399 kg;
- The remaining calculation is to calculate the fine aggregate content. As noted in the second paragraph of this section, the calculated total aggregate solid volume in this concrete mix was 0.700 m³ per m³ of concrete. The volume of blended coarse aggregate is simply the SSD mass divided by the SSD particle density = 998 kg / 2,700 kg/m³ = 0.370 m³;
- The fine aggregate volume is equal to 0.700 m³ – 0.370 m³ = 0.330 m³. The SSD fine aggregate mass is calculated from this volume of fine aggregate by multiplying it by the SSD particle density of the fine aggregate = 0.330 m³ × 2,550 kg/m³ = 842 kg/m³;
- The final Aggregate blend for this mix is:

SSD Coarse Aggregate A: 599 kg;
 SSD Coarse Aggregate B: 399 kg;
 SSD Fine Aggregate: 842 kg.

The British 'Road Note No. 4' Method

This method blends the solid volume of aggregates to achieve a target grading of the combined coarse and fine aggregates based on a series of four 'preferred grading curves'. An example of these curves is given for a 20 mm

maximum aggregate size concrete in **Figure III.3**.

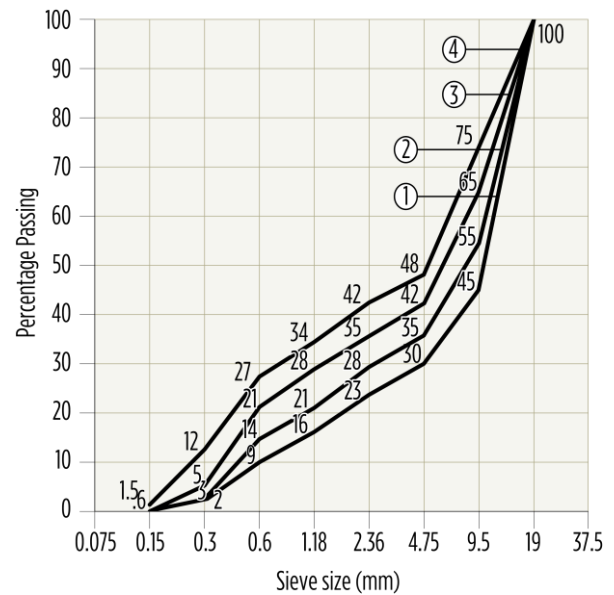

Figure III.3 – Road Note No. 4 [5] – Target Grading for 20 mm Maximum Size Aggregate

The four curves in **Figure III.3** numbered 1, 2, 3 and 4 need some care when applying them to general concrete. In the worked mix design example used in this section the volume of paste has been noted as being 0.300 m³ per m³ of concrete. This volume of paste reflects a concrete mix with approximate W/C ratio of 0.75 and associated lower cement content. Generally, it would be recommended to use grading curve number 4 (in **Figure III.3**). As the W/C ratio is reduced the most suitable target grading moves progressively to curves numbered 3 then 2 and finally to curve 1 as the W/C ratio drops to approximately 0.40 or below.

A worked example is carried out to demonstrate this method using the same aggregates as those nominated in the previous ACI 211.1 method worked example.

The method uses a volumetric grading and it is assumed that coarse aggregates A and B have identical SSD particle density as they are from the same source of aggregate. The blended coarse aggregate SSD particle density will therefore apply to both components.

To determine the blended coarse and fine aggregate grading a simple process, as

demonstrated in the ACI 211.1 method (also **Table III.8**), is used except that three aggregates are blended in this case. The aim of the blending is to produce a combined grading with a 'best fit' to the target grading from **Figure III.3**.

The blending process is best demonstrated in a table form (see **Table III.9**). The values in **Table III.9** are the result of numerous iterations to achieve the best fit from the materials used, which in this case is 22.5% by volume of 'coarse aggregate A' + 31.9% by volume of 'coarse aggregate B' + 45.6% by volume of 'fine aggregate'. The total of the combined aggregate percentages must be 100.0%. It should be noted that the best fit is rarely a perfect fit and depends on the grading of individual component aggregates.

The result of this curve fitting can also be demonstrated in a graph form (**Figure III.4**).

ACTUAL GRADING Vs. TARGET GRADING

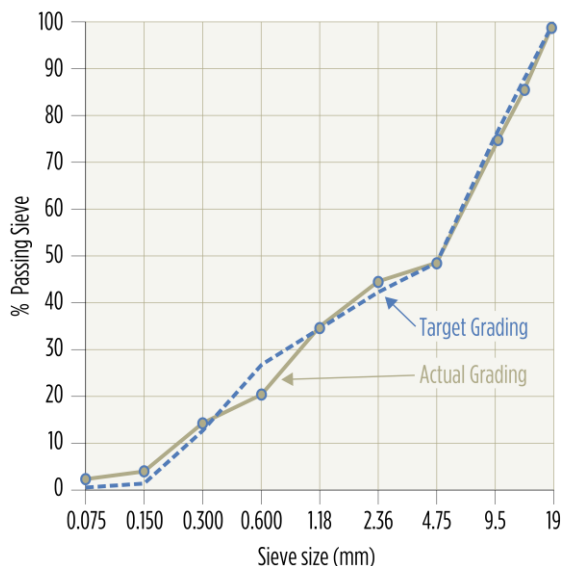

Figure III.4 – Graph of Combined Aggregate Best Fit Grading versus Target Grading

Having determined previously that the total volume of coarse and fine aggregates is equal to 0.700 m³, it is a simple process to calculate the solid volume of each individual aggregate by multiplying the percentage of that aggregate in the 'best fit' blend by the total volume.

The solid volumes of each aggregate are calculated:

- Coarse Aggregate A: 0.700 m³ × 22.5% = 0.158 m³;
- Coarse Aggregate B: 0.700 m³ × 31.9% = 0.223 m³;
- Fine Aggregate: 0.700 m³ × 45.6% = 0.319 m³.

From these solid volumes the total SSD mass of each aggregate in a cubic metre of concrete can be estimated by multiplying the solid volume by the particular aggregate SSD particle density:

- Coarse Aggregate A: 0.158 m³ × 2,700 kg/m³ = 425 kg;
- Coarse Aggregate B: 0.223 m³ × 2,700 kg/m³ = 603 kg;
- Fine Aggregate: 0.319 m³ × 2,550 kg/m³ = 814 kg.

The final Aggregate blend for this mix is:

SSD Coarse Aggregate A: 425 kg;
 SSD Coarse Aggregate B: 603 kg;
 SSD Fine Aggregate: 814 kg.

It can be seen that these batch masses are slightly different to those estimated by the ACI 211.1. They have a greater quantity of coarse aggregate and less fine aggregate although the total mass of aggregate is almost the same.

Neither of the methods is 'right' or 'wrong' but in sub-section 3 the next steps taken from this theoretical mix design are explored.

3. ASSESSMENT OF A THEORETICAL MIX DESIGN

3.1 GENERAL

Steps 6 and 7 in sub-section 2.3 noted that the theoretical mix design must be assessed by laboratory trial mix and ultimately in a full-scale field trial before the mix is accepted for general supply.

The key properties of concrete that need to be assessed are split into two parts:

- Plastic properties of concrete;
- Hardened properties of concrete.

The final mix design accepted for supply will generally be adjusted from the original theoretical design mix through the trial mix program. This step is critical in the overall mix design process.

Table III.9 – Combined Aggregate Best Fit Grading

Sieve size (mm)	Concrete aggregate grading			Blend grading	Target grading (Curve 4)
	Coarse aggregate A	Coarse aggregate B	Fine aggregate	22.5% A + 31.9% B + 45.6% FA	
26.5	100	100	100	100	100
19	95	100	100	98.9	100
13.2	35	100	100	85.4	87
9.5	10	85	100	75.0	75
4.75	2	8	100	48.6	48
2.36	1	2	95	44.2	42
1.18	0	0	75	34.2	34
0.6	0	0	45	20.5	27
0.3	0	0	30	13.7	12
0.15	0	0	8	3.6	1.5
0.075	0	0	4.5	2.1	0.5

Plastic Properties of the Concrete Mix Design

The trial batch of concrete is most commonly assessed for:

- Slump;
- Air Content;
- Wet Density;
- Yield;
- The Appearance of Concrete is also assessed visually for acceptable workability, potential for segregation and ease of finishing.

Tests for these plastic properties will need to meet the specified or acceptable requirements

before longer term hardened properties are assessed. If any of the properties (particularly slump, air content and yield) are not as specified or as expected then mix design correction may need to be made based on the common relationships of mix design to these properties.

Hardened Properties of the Concrete Mix Design

Having satisfied the requirements for plastic properties of the (adjusted) mix, the trial batch of concrete is assessed for its hardened properties. These may vary with specification but commonly include:

- (a) Compressive strength at various ages;
- (b) Flexural Tensile strength at various ages;
- (c) Drying Shrinkage up to 56 days;
- (d) Various specified durability tests.

If any of these tests do not conform to the specified or expected values, then adjustments may need to be made based on the common relationships of mix design to these properties.

3.2 MIX DESIGN ADJUSTMENTS FOR PLASTIC PROPERTIES

Common adjustments are discussed based on correcting the concrete mix to achieve the required plastic properties.

Slump Adjustment

The concrete slump can be most simply adjusted through varying an admixture dosage, but care must be taken to ensure that side effects (e.g. on set time) are accounted for. Increased water reducing admixture will generally increase the slump and decreasing the admixture dose will decrease the slump.

An alternative to adjusting admixture dosage is to adjust the mix total water. The relationship between slump and the total water content of a mix is noted in **Table III.3** and can guide a change in water content. For example, if a trial mix slump was measured as 40 mm but the required target slump for a 20 mm maximum size aggregate mix was 80 mm, then an increase of approximately 12 Litres/m³ of water could be used to correct the slump. Unfortunately, this will have a side effect on the W/C ratio and may significantly impact on other hardened properties. In order to avoid such a side effect then the cement (or Cement + SCM) content could be increased in proportion with the water content. In this case, assuming a target W/C ratio for the mix is 0.50, the increase in cement content (or SCM + cement content) will need to be 12 Litres/m³ / 0.50 = 24 kg/m³. By maintaining the W/C ratio the strength and related properties may be maintained.

Air Content Adjustment

The concrete air content is normally adjusted by raising or lowering the dose rate of air entraining agent.

Wet Density and Yield Adjustment

The wet density variation in concrete generally relates to impacts of varying constituent material quantities and their variation in density. If the theoretical mix design has been batched at the correct slump and air content, then it is expected that the wet density will be the same as that calculated for 1.000 m³ of that concrete mix design. In some cases, the measured density is higher or lower than the design value. For example, total mass of batched materials for a mix design is 2,350 kg/m³. When tested the plastic density is found to be 2,320 kg/m³. This means that the concrete mix yield is equal to 2,350/2,320 = 1.013 (i.e. it is 'over-yielding' by 1.3% in this case). The simple mix correction is to divide the mix design batch masses by the yield (1.013) to correct the mix design. This method works in the opposite case where the batch mass is less than the measured plastic concrete density ('under-yield') except that in this case the mix ingredients will be proportionally increased.

Adjustment for General Appearance and Workability

The most common cases in which this occurs are where the mix appears to have too much coarse aggregate and looks harsh and has poor workability or the opposite where the mix appears to have too much sand and may be segregating. Corrections to these are generally made by adjusting the ratio of sand to coarse aggregate but in some cases, may require a complete change of aggregate if that is possible.

Concrete that is pumped into position will most likely need an adjustment of the coarse aggregate to fine aggregate ratio from that of a mix being directly deposited from the truck into a 'kibble' or into forms. In some cases, concrete pump manufacturers do provide target grading curves and specifications for concrete mix design used in their own pumps.

3.3 MIX DESIGN ADJUSTMENTS FOR HARDENED CONCRETE PROPERTIES

Common adjustments are discussed based on correcting the concrete mix to achieve the required hardened concrete properties.

Adjustments for Strength and Durability

The reason for grouping the strength tests and durability test impact on mix design is that in most cases the various types of strength tests are related to concrete compressive strength. Most of the commonly specified durability tests are also related to compressive strength as a result of its relationship to mix W/C ratio.

In all of these tests the correction to mix design will most likely require an adjustment to the mix W/C ratio or less commonly a complete change to cement type, aggregate type or admixture combination.

As seen in sub-section 2.5 there is a direct relationship between W/C ratio and compressive strength at various ages. A smaller adjustment in compressive strength generally requires modification of the W/C ratio. For example, a GP Cement mix designed with a target 28-day strength of 37.5 MPa is trial batched and only achieves 33.0 MPa. A review of **Figure III.1** would suggest that a reduction in W/C ratio by approximately 8% will be required to achieve the necessary change in strength. This can be achieved by increasing the cement content by 8% or reducing the water by 8% (or a combination of water and cement contents to reduce W/C by 8%). If the existing mix cement content was designed as 280 kg/m³ and it was decided to correct this, then it would require a cement content increase of 20 kg/m³ to increase strength as well as an adjustment of the mix design aggregate contents to maintain yield due to the increased paste content created by increasing the cement.

Adjustment for Drying Shrinkage

The drying shrinkage of concrete is partly related to the total water content of concrete and to the type of cement, properties of the coarse aggregate and the ratio of coarse aggregate to fine aggregate in the mix design. A reduction in drying shrinkage of

100 micro-strain at 56 days can be achieved by some of the following adjustments to an existing mix:

- A reduction of total water of 30 Litre/m³. This may be achievable with a high range water reducing admixture, but care is needed in selection of the HRWRA as some do increase drying shrinkage at the same water content;
- An increase in coarse aggregate content of the concrete mix by 100 kg/m³ by reducing the fine aggregate content to compensate yield. This may be possible if the concrete is not being pumped;
- Addition of a shrinkage reducing admixture at the required design dosage to the mix.

4. REFERENCES

- 1) AS 3600 – *Concrete structures*
- 2) AS 1379 – *Specification and supply of concrete* (R2017)
- 3) AS 2758.1 – *Aggregates and rock for engineering purposes – Concrete aggregate* (2014)
- 4) ACI 211.1 – *Standard Practice for Selecting Proportions for Normal, Heavyweight, and Mass Concrete* (R2002)
- 5) UK Road Research Laboratory, '*Road Note No. 4 – Design of Concrete Mixes*', London (1950)
- 6) AS 1141.4 – *Methods for sampling and testing aggregates – Bulk density of aggregate* (R2013)
- 7) ASTM C29 – *Standard Test Method for Bulk Density ('Unit Weight') and Voids in Aggregate* (2017)
- 8) ASTM C33 – *Standard Specification for Concrete Aggregates* (2018)

GUIDE TO CONCRETE CONSTRUCTION

T41



CEMENT CONCRETE
& AGGREGATES AUSTRALIA

CONTENTS

1. OUTLINE	2
2. SPECIFYING CONCRETE	2
2.1 GENERAL.....	2
2.2 NORMAL-CLASS CONCRETE	3
2.3 SPECIAL-CLASS CONCRETE.....	3
3 ORDERING CONCRETE	4
3.1 GENERAL.....	4
4 REFERENCES.....	6

1. OUTLINE

This section deals with the issues that need to be addressed when specifying concrete for a project and when ordering concrete for supply to the construction site.

AS 1379 '*Specification and supply of concrete*' covers the supply of all concrete including site-mixed, factory-mixed, and truck-mixed concrete. In addition to specifying requirements for concrete materials, plant and equipment, the Standard sets out procedures for the specification and ordering of concrete, its production and delivery, and its sampling and testing for compliance with the requirements of the specification.

This section comments on general matters regarding specifications and the procedures for specifying concrete in the Standard. The principles governing specification aim to ensure the supply of a material that meets, consistently and uniformly, the parameters for the concrete assumed in the design in terms of strength, serviceability and durability. The provisions in the Standard for ordering concrete are also covered.

2. SPECIFYING CONCRETE

2.1 GENERAL

The general principles for specifying concrete are the same as those for any other material. The specifications along with the plans are the mediums by which the designer's intentions for

the project are communicated to the contractor. While they also function as legal documents setting out the requirements to be fulfilled by the parties to the contract, this should not override or obscure the primary function of communication.

The requirements in both documents should be consistent, clear and unambiguous. Above all they should be consistent (e.g. using the one terminology for the same parameter every time it is used). A variety of arrangements is possible for the production and delivery of concrete to construction sites. To help achieve some uniformity, efficiency and economy in the production and delivery of concrete, AS 1379 sets out a number of standard ways in which concrete may be specified and ordered in accordance with that Standard.

In essence, it provides for two classes of concrete:

- **Normal Class**, which is intended to cover concrete which can be basically specified by standard strength grade, the specification and ordering of which has been simplified as far as practicable;
- **Special Class**, which allows for the specifier to incorporate into the project specification any special requirements for concrete for all or part of the project.

Special-Class concrete will generally be more costly than Normal-Class concrete because of the additional requirements imposed on the manufacturer. Further, there will be additional cost incurred because of the additional testing required to demonstrate that the concrete meets the specified requirements.

Particular attention is drawn to the overall limitations on the acid soluble chloride ion and acid soluble sulfate ion contents of concrete. Derived from all sources, these must not exceed 0.8 kg/m³ of concrete for chloride ion content, and 50 g/kg of cement for sulfate ion content, unless otherwise specified. Some specifications may allow a higher limit for acid-soluble chloride ion content where the concrete is not to be reinforced. AS 3600 '*Concrete structures*' and AS 1379, for example, allow 2.0 kg/m³ of acid soluble chloride ion content for such applications.

A detailed proposal for a suggested model of a 'General Specification for Concrete Construction' is provided in Part XI of this Guide.

2.2 NORMAL-CLASS CONCRETE

Normal-Class concrete is specified by reference to a number of basic parameters that describe the characteristics of concrete. They are:

- The strength grade (either N20, N25, N32, N40, or N50), or the corresponding characteristic strength (either 20, 25, 32, 40, or 50 MPa at 28 days);
- The slump required at the point of acceptance – either 20, 30, 40, 50, 60, 70, 80, 90, 100, 110 or 120 mm;
- The maximum nominal size of the aggregate, either 10, 14 or 20 mm (note the default value is 20 mm);
- The intended method of placement;
- If project assessment is required (note if not specified it is assumed it is not required); and
- The level of entrained air (if required).

Standardisation of strength grades enables more test results to be generated for each grade and this has benefits for improved quality control of all strength specified products. It also eliminates or reduces unnecessary and one-off mix designs.

Concrete specified as Normal Class also has a number of limitations imposed on it by AS 1379. These relate to the type and quality of materials which may be used, the mass per unit volume of the concrete, the acid-soluble chloride and sulfate content, shrinkage strain and mean compressive strength. These latter parameters cannot be nominated or varied by the specifier and the concrete still be called Normal Class.

Specifiers should be aware of the values imposed by AS 1379. If they need to vary or control any parameter apart from those in the list of basic parameters, then the concrete must be nominated as Special Class.

AS 1379 provides a specification for basic assessment of a supplier's product range. This,

and limits on tested values, provides a basis for the concrete suppliers quality control system and is referred to as Production Assessment. Production Assessment is targeted at production of concrete and is not required to be carried out on any particular site (i.e. sampling locations are assumed to be random).

Project assessment is a quality audit procedure which determines whether the concrete supplied to a particular project complies with the requirements of the specification. If project assessment is to be carried out the results may be used as part of the Production Assessment if desired. In this context, it should be noted that a supplier is required, by requirements in AS 1379, to guarantee the performance of Normal-Class concrete in terms of the parameters specified in the purchase order and those set out in AS 1379. Note also that unless specified it will be assumed that project assessment is not required.

There are some additional requirements of Normal-Class concrete that are provided in AS 1379, namely:

- That the concrete compressive strength is assessed and must comply with the requirements set out for Production Assessment;
- That the concrete slump is delivered to site within an acceptable range of the target slump as indicated in AS 1379;
- That the drying shrinkage of the concrete production is assessed as required in AS 1379 and that the 56-day drying shrinkage of a product is less than 1,000 microstrain;
- That the mean 7-day strength of a concrete mix must exceed limits set out in AS 1379.

2.3 SPECIAL-CLASS CONCRETE

Simply, Special-Class concrete is any concrete which cannot be specified as Normal Class. Specifically, it is concrete which is specified either in some way other than that set out for Normal-Class concrete (e.g. by specifying a higher standard strength grade; imposing a limit on shrinkage of 600 microstrain or imposing a

limit on the range for density), or where the purchaser wishes to vary or add other requirements to those set out for Normal Class, (e.g. specifying a value for slump of 45 mm; specifying a specific aggregate to achieve a required colour; specifying a non-standard or early-age strength requirement; or specifying a maximum water/cement ratio).

The standard strength grades outlined in AS 1379 and AS 3600 should be noted here. They can be either of 20, 25, 32, 40, 50, 65, 80 or 100 MPa at 28 days. It should also be noted that standard strength grades of 65 MPa or higher are automatically deemed to be Special-Class concrete and that strength grades of 80 MPa or higher may not be available from all concrete plants due to special aggregate, admixture and binder needs in some cases.

In addition to strength requirements there are also potential exposure classification durability classes required by AS 3600 that dictate a Special-Class concrete. This results from the special aggregate requirements for concrete used in exposure class B2, C1, C2 and U as detailed in AS 2758.1 and means that both 40 MPa and 50 MPa characteristic strength concrete may need to be deemed as Special Class when exposed to these environments (typically in near coastal, marine and other aggressive environments).

Special-Class concrete may be specified in one of two ways – as a Special-Class performance concrete or as a Special-Class prescription concrete. In the former case, the physical parameters or criteria specified may be those discussed in AS 1379 or may be some other physical parameters. In the case of Special-Class prescription concrete, the specifier is required to set out the proportions of materials they want and any limitations on those materials.

In either case, the specifier should set out in the specification how the properties are to be measured and give criteria for compliance with the specification. Appendix B of AS 1379 gives guidance on specifying Special-Class concrete.

It should be clearly understood that, under AS 1379 provisions, a supplier is freed of the obligation to guarantee the physical properties

of the concrete if it is specified by proportions. In this instance (i.e. Special-Class prescription concrete), the supplier is required to warrant only that the specified prescription has been met.

3 ORDERING CONCRETE

3.1 GENERAL

It is most important when concrete is being ordered from an external supplier that the supplier is made fully aware of all the requirements specified for the concrete in the project specification.

It is first necessary to advise the supplier if the concrete is either 'Normal Class' or 'Special Class'. This should be stated in the contract documents (e.g. plans and specifications) and depends on whether the specification for the concrete contains requirements other than those permitted by AS 1379 for Normal-Class concrete. If the concrete is Normal Class, then AS 1379 sets out a series of parameters that have to be specified by the customer:

- A standard strength grade;
- The slump at the point of acceptance;
- The maximum nominal size of aggregate;
- The intended method of placement;
- Whether or not project assessment is required to be carried out by the supplier;
- If required, a level of air entrainment.

Values for each of these parameters will be set out in the project specification. If there is any doubt about any of them, the specifying authority should be consulted. It is important that the quality of the concrete matches that assumed in the design otherwise there may be a deficiency in strength or durability performance.

In this context, it should be noted that a supplier is required, by AS 1379, to guarantee the performance of Normal-Class concrete in terms of the parameters specified in the purchase order and those set out in the Standard. Note also that unless specified it will be assumed that project assessment is not required.

When Special-Class performance concrete is specified, the order should include all the

requirements set out in the project specification for the concrete. In accepting the order, the supplier guarantees the concrete in terms of the physical parameters which have been specified, and, if appropriate, the criteria for compliance. It is particularly important that there be no misunderstanding at this point. AS 1379 sets out criteria for judging compliance and, if these are to be varied or over-ruled, it is important that this be clearly understood.

The order should also include the following information:

- The name of the project;
- The address and details of the delivery location, including any restrictions that may apply (e.g. traffic and time of working);
- The volume of the total order;
- The time for the delivery of the first batch and the rate of delivery;
- The name and contact details of the person responsible for the concrete at the site and a contact who should be advised if there are any problems with delivery.

Similarly, it should be clearly understood that, under AS 1379 provisions, a supplier is freed of the obligation to guarantee the physical properties of the concrete if it is specified by proportions. In this instance (i.e. Special-Class prescription concrete) the supplier is required to guarantee only that the specified prescription has been met.

It is important, therefore, when preliminary enquiries are being made with a supplier, to indicate whether Normal or Special-Class concrete will be required. The latter is almost invariably more costly than the former, for equivalent strength grades, because of the additional requirements imposed on the manufacturer.

Ordering procedures are very much standardised. However, it is still possible for mistakes to be made if the clear difference between Normal and Special-Class concrete is not recognised at that point.

4 REFERENCES

- 1) AS 1379 – *Specification and supply of concrete* (R2017)
- 2) AS 3600 – *Concrete structures* (2018)
- 3) AS 1012 – *Methods of testing concrete*
- 4) AS 3972 – *General purpose and blended cements*
- 5) AS 2758.1 – *Aggregates and rock for engineering purposes – Concrete aggregates*
- 6) AS 3582.1 – *Supplementary cementitious materials, Part 1: Fly ash*
- 7) AS 3582.2 – *Supplementary cementitious materials, Part 2: Slag – Ground granulated iron blast-furnace*
- 8) AS 3582.3 – *Supplementary cementitious materials, Part 3: Amorphous silica*
- 9) AS 1478.1 – *Chemical admixtures for concrete*

This section outlines the requirements for the manufacture of concrete. It is described only to the extent necessary to provide the reader with some background to the selection and proportioning of materials, to the various steps in the manufacturing process and to some of the quality-related requirements.

CONTENTS

1. INTRODUCTION	2
2. PLANT-MIXED CONCRETE	2
2.1 GENERAL.....	2
2.2 BINS AND SILOS	2
2.3 WEIGHING EQUIPMENT.....	3
2.4 LIQUID-DISPENSING EQUIPMENT .3	
2.5 MIXERS.....	4
2.6 PRODUCTION AND DELIVERY	5
3. SITE-MIXED AND PACKAGED CONCRETE	6
3.1 SITE MIXING	6
3.2 PACKAGED CONCRETE MIXES.....	7
4 REFERENCES	8

1. INTRODUCTION

AS 1379 'Specification and supply of concrete' provides requirements for site-mixed, factory-mixed, and truck-mixed concrete. In addition to specifying requirements for concrete materials, plant and equipment, the Standard also sets out procedures for the specification and ordering of concrete, its production and delivery, and its sampling and testing for compliance with the requirements of the Standard.

In today's construction industry, most construction sites are supplied with concrete from a central batching plant, operated either by the contractor or by a separate, independent supplier. Whilst obviously there will be some differences in procedures in ordering and testing concrete if the contractor owns their own plant, the principles governing manufacture and delivery are essentially the same in both situations. The aim is to ensure the supply of concrete that (a) meets the plastic- and hardened-state requirements of the project specification, and (b) performs consistently.

2. PLANT-MIXED CONCRETE

2.1 GENERAL

It is beyond the scope of this Guide to discuss, in great detail, the plant and equipment used in the manufacture of concrete. **Figure 9.1** illustrates the layout of a typical concrete batching plant and the following sub-sections describe the basic physical requirements and performance requirements of the main plant elements.

2.2 BINS AND SILOS

In modern concrete plants, bins and silos are used to store (a) the various aggregate materials used in the manufacture of concrete, (b) the cementitious materials, and sometimes (c) liquid admixtures. In older or project-based temporary concrete plants, ground storage may be used for coarse and fine aggregate storage. In these plants, front-end loaders are normally used to transfer the aggregates to the weigh hopper for batching.

The following general requirements apply to all storage units:

- They should be constructed so as to prevent contamination from other materials and, in the case of aggregate bins and silos, to keep aggregates of different types and sizes from intermingling;
- Aggregate storage units should facilitate the free drainage of the materials and be designed to minimise segregation;
- Each storage unit should be provided with a means of actively controlling the discharge from the unit;
- Bins and silos used for cement and other cementitious materials must be designed and constructed to keep the contents dry and to promote the complete discharge of the contents;

- Cement/ cementitious silos must include engineered systems to ensure that over-filling of the silo either (a) cannot occur or (b) triggers an alarm, and must also have a system to prevent dust emissions to the atmosphere;
- Bins and silos which are used to store more than one type of constituent shall be capable of being cleaned out thoroughly and inspected internally;
- Bin and silo contents must be clearly marked to prevent contamination when new loads are delivered.



Figure 9.1 – Typical Modern Concrete Batching Plant

2.3 WEIGHING EQUIPMENT

All weighing equipment in central batching plants should be provided with a visual weight-indicating device that is clearly visible to the operator in control of the equipment, and which should be graduated to a scale compatible with the accuracy required for the production process. The weighing equipment itself should be accurate to $\pm 0.4\%$ (or less) of the maximum scale value when statically loaded. The equipment should also be checked for accuracy, at least every six months, but more often if required for the particular type of equipment. Section 3.3 of AS 1379 describes the requirements in detail.

2.4 LIQUID-DISPENSING EQUIPMENT

All liquid-dispensing equipment (e.g. for dispensing admixtures) should also be equipped with a visual metering device that is clearly visible to the operator. The equipment should be capable of metering the volume (or mass) of liquid to an accuracy of at least $\pm 5.0\%$ of the indicated value, except for water which should be metered or weighed to an accuracy of at least $\pm 2.0\%$.

As with weighing equipment, calibration of the equipment should be undertaken at least every six months, or more often if required for specific equipment.

Liquid-dispensing equipment should be cleaned between changes in types of liquid products including changes in brands of the same type of product, and at a frequency not less than that recommended by the manufacturer.

2.5 MIXERS

General – A variety of mixers – ranging from the simple tilting-drum mixer (used almost universally to produce bricklaying mortar on housing sites) to the much more sophisticated split-drum mixers as used on major concrete road projects – are used to mix concrete. In the simpler mixers, the materials are generally batched by volume which is less precise. In more complex plants, the materials are batched accurately by mass with a relatively high degree of precision. It should be noted though that concrete is invariably supplied to customers and users by volume.

Although the tilting-drum mixer and its companion, the horizontal-drum mixer, were once widely used to mix concrete on construction sites, they have now largely been replaced by the inclined-drum mixer and the split-drum mixer. By far the most widely-used method for manufacture of concrete used by the construction industry today is mixing in inclined-drum mixers mounted on trucks – known as transit mixers. (Transit mixers (**Figure 9.2**) are also known colloquially as ‘agitators’ or ‘agi’s – terms which do not fully describe the mixing action that occurs in these mixers.)



Figure 9.2 – Transit Mixer (aka concrete Agitator or ‘Agi’)

The transit mixers are loaded with accurately weighed dry materials (aggregates and cementitious products) and liquid materials (water and admixtures) at a central batching plant and, while operating at mixing speed, mix the batch of concrete for sufficient time to achieve complete mixing of the materials (which means producing a plastic concrete product that has similar properties (workability and cement and aggregate content) throughout

the whole batch). This process is generally known as ‘dry batching’. A complex blade and fin system within the mixing ‘bowl’ or drum operates to (a) mix the batched materials thoroughly when the drum is rotated in the ‘mixing direction’, and (b) allows the mixed concrete to be discharged continuously from the drum when it is rotated in the reverse direction.

While concrete batching can be carried out in relatively small and simple plants, it is now the case that in larger cities, large ‘central batching plants’ are common. These plants allow high volume, high quality concrete production with a relatively small plant footprint. The use of multiple silos for a variety of cementitious materials and multiple overhead bins for aggregate materials – coupled with the ability to batch more than one transit mixer at a time – allow these modern concrete plants to achieve very high throughput and to produce a wide variety of concrete mixes while also meeting stringent environmental control requirements around dust and noise emissions.

For some major projects where there are requirements for high production rates and very consistent quality, split-drum mixers are preferred. These split-drum (high energy, high efficiency) mixers can produce high throughput and very consistent quality. For major projects like concrete road paving, this type of performance is critical. The split-drum mixers can also mix concrete with maximum size aggregates as large as 150 mm with mixing times of 60-70 seconds, which is advantageous for high volume projects like concrete dam construction. With split-drum mixers, all of the materials (cementitious + aggregates + water + admixtures) are added together in the drum prior to mixing. Once the concrete is mixed the drum ‘splits’ open and the plastic concrete is discharged into a conventional concrete truck (Transit mixer/ Agitator) or in some cases, where low slump (20-40 mm) concrete is being produced (typically for road paving machines), the concrete is discharged into tipper trucks which are adequate for short transport distances. This batching process is known as ‘wet batching’.

Continuous mixers (e.g. pugmills) (**Figure 9.3**) are also used from time to time – mainly for the production of high volumes of low slump concrete (e.g. roller compacted concrete) for dam and road or hardstand construction.



Figure 9.3 – Continuous Mixer (aka 'Pug Mill')

Australian Standard Requirements – AS 1379 sets out a number of requirements to govern the performance of both batch and continuous mixers. These include:

- A requirement that batch mixers have mounted on them an identification plate which provides information on:
 - the gross internal volume of the mixing chamber (m³);
 - the rated mixing capacity (m³);
 - the recommended minimum –

number of revolutions of the mixer required to achieve uniformity in the concrete; or

mixing time (in minutes) at a given rotational speed of the mixer (in revolutions per minute).

- if the mixer is designed to be used as an agitator -

the recommended capacity of the mixer used as an agitator; and

the recommended speed of the mixer (in revolutions per minute) when used as an agitator.

- Limits on the capacity of the mixer to no more than 65% of the gross internal volume of the bowl when used as a mixer, and no more than 80% when used as an agitator unless testing in accordance with the Standard permits a higher figure;
- Procedures for determining or confirming the minimum mixing time or number of revolutions at mixing speed for batch mixers.

Continuous mixers are also required to carry an identification plate that indicates both (a) the name of the manufacturer, and (b) the maximum discharge rate in tonnes per hour.

2.6 PRODUCTION AND DELIVERY

AS 1379 sets out a number of requirements governing the production and delivery of concrete from both batching plants and continuous mixers.

The following are of particular note:

- Where the characteristic compressive strength of the concrete is more than 15 MPa at 28 days, all ingredients, other than liquids, have to be proportioned by mass. Volume proportioning may be used for concrete having a characteristic strength of 15 MPa or less at 28 days;
- The quantity of each ingredient in a batch should be measured within the tolerances shown for the ingredient in **Table 9.1**;
- Water may be added to a mixed batch of concrete, prior to its complete discharge, only if the following relevant conditions are satisfied:
 - The supplier's approval is obtained. (Only the supplier's representative can add water or admixtures to a mixed batch prior to its discharge. This is because the supplier is responsible for the quality of the concrete up to the point of acceptance of delivery. The addition of water and/or admixtures will affect the quality of the concrete and may cause it to fail to meet the specified properties.);

- Immediately after the water is added, the mixing bowl is rotated for 30 revolutions at mixing speed, or for such time as is necessary to re-establish the uniformity of the mix;
 - If slump has been specified, then immediately after uniformity of the mix has been re-established following water addition the slump is measured, and any slump requirement is met;
 - If a sample is to be tested, then the sample is to be taken after the addition of any extra water and uniformity re-established;
 - If water is added once discharging has commenced, this fact is noted on the identification certificate for the batch;
 - If a maximum water/cement ratio has been specified, the quantity of water added does not cause the specified maximum ratio to be exceeded.
- Discharge of all concrete from the batch should be completed within 90 minutes of mixing having been commenced (or sooner if proper placement and compaction cannot otherwise be achieved). This requirement may be waived, however, if the consistency of the concrete can be maintained for a longer period without the addition of extra water to the mix;
 - Unless otherwise specified, concrete at the point of delivery should have a temperature not less than 5°C and not more than 35°C. (For additional precautions in extreme weather conditions, see Section 18 'Hot- and Cold-Weather Concreting'.)

Table 9.1 – Permissible Tolerances on Batch Ingredients (excluding water) – Table 4.1 in AS 1379

Ingredient	Tolerance			Volume batching
	Weight batching for batch size, Q			
	Q <2 m ³	2 ≤ Q ≤4 m ³	Q >4 m ³	
Each cementitious ingredient	-5 + 30 kg	-10 + 30 kg	-20 + 40 kg	±1%
Total cementitious materials	-5 + 30 kg	-10 + 30 kg	-20 + 40 kg	±1%
Fine aggregate	-75 + 50 kg	±75 kg	±100 kg	±2%
Coarse aggregate	-75 + 50 kg	±75 kg	±100 kg	±2%
Total aggregate	-75 + 50 kg	±75 kg	±100 kg	±2%
Chemical admixtures	±5%*	±5%*	±5%*	±5%*

NOTE: * or 20 mL whichever is the greater

3. SITE-MIXED AND PACKAGED CONCRETE

3.1 SITE MIXING

While it is now rare for mixing to be done on project sites (except for very large or remote projects where a dedicated batching/ mixing plant may be established), there are occasions when site mixing is necessary (e.g. small

quantities of concrete may be required in which special aggregates are incorporated). In some cases, small but significant projects may be located in areas remote from normal sources of supply. In such cases, some knowledge of the proper proportioning of concrete mixes is necessary. An informative text such as 'Australian Concrete Technology' (edited by W G Ryan and A Samarin, published by Longman Cheshire, Melbourne) should be consulted if

detailed information is required to facilitate technically-sound 'site mixing'.

Materials handling and storage on a project site should be sufficient to:

- Prevent contamination of concrete materials by extraneous materials;
- Prevent segregation of the aggregates or intermingling of the different aggregate sizes;
- Ensure that cementitious materials are kept dry by storing them in either (a) weathertight silos; (b) enclosed weathertight buildings; or (c) on pallets that are off the ground and protected from wet weather;
- Ensure that SCM's such as fly ash or GGBFS, if used, are clearly identified and separated from the type GB cement;
- Ensure that admixtures are clearly identified, protected from extremely hot or cold weather and properly dispensed.

Mixing on-site for small projects can be done in either tilt-drum or horizontal-drum mixers. The former may range in size from as little as 50 litres (0.05 m³) to as large as 6-10 m³; while the latter are typically used on large volume projects such as dams. Horizontal-drum mixers range in size from 100 litres to 5 m³ (Figure 9.4).



Figure 9.4 – Typical Small On-site Plant with Capacity of about 10 m³ per hour.

The order of loading materials when batching is important. Ideally, the coarse aggregate plus a little of the mixing water should be loaded first as this helps clean the mixer drum. This is then followed by the sand, the cement and finally the remaining water. Where a loading skip is employed, a layer of coarse aggregate, followed by a layer of cement, and finally a layer of sand will help prevent the fine cement being blown away.

Efficient mixing will be promoted if the mixer is not overloaded. Loading above the rated capacity will increase mixing time disproportionately or result in incomplete mixing leading to low and variable strengths. Similarly, too short a mixing time will result in patchy, non-uniform and low-strength concrete. Excessive mixing times may also be undesirable and may lead to grinding of any soft aggregates which can produce more fines and increase the water demand of the concrete. A good rule is to allow 1.5 minutes for mixing 1 m³ plus 0.5 minutes for each additional 0.5 m³.

3.2 PACKAGED CONCRETE MIXES

Where reasonably small quantities of concrete are required, bagged concrete can provide an alternative to batching on-site. Packaged to provide approximately 10 litres (or 0.01 m³) of plastic concrete, bagged concrete mixes may be expected to achieve strengths of around 15 MPa at 7 days when slump is in the range of 75-100 mm. The quantity of water required to achieve this slump is normally marked on the bag. Some caution should be exercised, however, in relying on packaged concrete to achieve specified strengths.

4 REFERENCES

- 1) AS 1012 – *Methods of testing concrete*
- 2) AS 1379 – *Specification and supply of concrete*
- 3) AS1478 – *Chemical admixtures for concrete, mortar and grout*
- 4) AS 1478.1 – *Admixtures for concrete*
- 5) AS 2758 – *Aggregates and rock for engineering purposes*
- 6) AS 2758.1 – *Concrete aggregates*
- 7) AS 3582 – *Supplementary cementitious materials*
- 8) AS 3582.1 – *Fly ash*
- 9) AS 3582.2 – *Slag – ground granulated blast- furnace*
- 10) AS 3582.3 – *Amorphous Silica*
- 11) AS 3600 – *Concrete structures*
- 12) AS 3972 – *General purpose and blended cements*

CONTENTS

1. OUTLINE	2
2. SUPPLY, DELIVERY AND TRANSPORT	2
2.1 SUPPLY	2
2.2 TRANSPORT OF CONCRETE	3
3. SUPPLY OF CONCRETE – BASIC REQUIREMENTS	4
3.1 CONTROL OF VOLUME	4
3.2 CONTROL OF ADDITIONS DURING DELIVERY	4
3.3 CONTROL OF CONCRETE TEMPERATURE	5
3.4 CONTROL OF THE DELIVERY TIME OF CONCRETE	5
3.5 IDENTIFICATION OF DELIVERY ...	5
4. SPECIAL PROJECT DELIVERY REQUIREMENTS	6
4.1 SPECIALISED DELIVERY METHODS	6
5. REFERENCES	8

1. OUTLINE

This section discusses various aspects of the supply of premixed concrete including management of delivery and different methods used to deliver product.

AS1379 'Specification and supply of concrete' covers the supply of premixed concrete. This Standard covers topics such as the basis of supply of concrete, the allowable temperature, consistency and time from mixing the concrete to delivery on site. Also covered in this Standard are minimum requirements for documentation related to a batch of concrete and control of water or other materials added during delivery.

This Section also reviews the types of equipment used to transport mixed concrete to sites where the method of placement allows or demands higher rates or more efficient methods of supply.

2. SUPPLY, DELIVERY AND TRANSPORT

2.1 SUPPLY

This Section is largely about the supply and delivery of premixed concrete in its various forms. The most common method used in the Australian building and construction industry is a process with the following set of steps in sequence:

- Concrete materials are weighed in a fixed plant;
- Materials are conveyed to a transit mixer mounted on a delivery truck;
- Materials are mixed in the transit mixer at the fixed plant under controlled conditions;
- The mixed concrete is checked prior to being delivered to the customer's building site by the delivery truck;
- On receipt of the concrete on site the concrete is emptied from the transit mixer either directly into the customer's forms or into one of many possible means of moving the concrete from the transit mixer to the customer's forms (pumping, wheelbarrow, motorised skip, crane and kibble etc.) (Figure 10.1).



Figure 10.1 – Truck Mounted Transit Mixers delivering Concrete to a Pump on Site

While this appears to be a fairly simple process it ignores some of the complexities that are part of concrete supply.

A customer orders concrete to meet various specified requirements as detailed in Part IV, Section 8 of this Guide. One of the key requirements of the customer is that the

concrete must be delivered to the forms on site in a condition that is capable of being compacted with the equipment available to the customer or the placing sub-contractor. This is largely the reason for the concrete requiring a specified slump on site at the time of delivery.

For this requirement to be met, the elements that impact on the slump of concrete need to be recognised and carefully controlled. Slump of a batch of concrete at a point in time is dependent on several factors:

- The correct mix design being batched – including the initial mixing water;
- The time since water was added to the concrete. Freshly mixed concrete has chemical reactions starting from when water is added causing ‘absorption’ of water from the mix. Dry aggregates can also slowly absorb water from the mix. Water can be lost from concrete to the atmosphere during delivery. In each case the reduction of free water in the mix will lead to loss in slump;
- The ambient and concrete temperatures both affect the rate of water loss into the atmosphere as well as the rate of reactions.

From these factors it can be seen that for control of slump the delivery must be made using careful controls on batching, delivery time and concrete temperature. These are further discussed in sub-section 3 of this document.

One other step in the supply of concrete is the need for the concrete supplier to provide their customer with a certificate verifying the quantity and specified requirements for each delivery of concrete. This is necessary for both the suppliers’ and customers’ quality systems and is also required by AS 1379 ‘*Specification and supply of concrete*’. AS 1379 refers to this certificate as the ‘Identification Certificate’ but is also commonly referred to as ‘ticket’, ‘docket’ or ‘manufacturer’s warranty’. This is also discussed in sub-section 3 of this document.

2.2 TRANSPORT OF CONCRETE

Every concrete supplier and plant will have a specific method for managing transport of the premixed concrete to their customer’s site. The transport component of supply starts from when the concrete leaves the plant and travels to the defined point of ownership by the customer. It is common in Australia for the point of ownership by the customer to be where the concrete leaves the truck chute (e.g. in the case of the process outlined in 2.1). There are other methods of transporting concrete which can include:

- a) Pumping of concrete to a form or secondary pump;
- b) Conveyor to a fixed pump or crane and kibble system;
- c) Transport of concrete in a rear or side tipper system;
- d) Transport of concrete using a bucket and cable crane system.

The options noted are not all of the possibilities and each of a) to d) require the concrete plant to have a fixed ‘central mixer’ to work efficiently. The reasons for using some of the alternative delivery systems are explored in sub-section 4.

When concrete supply plants deliver using trucks and transit mixers have large numbers of customers and high output volume, the means of efficiently controlling the transport fleet becomes a key part of managing supply of concrete. Some Australian concrete suppliers have multiple concrete plants in the major cities and utilise truck tracking management systems to improve reliability and efficient use of transport. In this case a team of ‘dispatchers’ remotely monitor each truck location and activity (e.g. in transit to site, on site, unloading concrete or in transit back to the batch plant).

Where concrete is delivered by truck and transit mixer the driver has the responsibility to report back to the supplier’s plant management on any variation in procedures that may impact product quality on site or in transit to the site. Common variation to procedures includes management of water additions to the concrete in the transit mixer or addition of any admixtures or additives. AS 1379 does specify requirements to be met

in the case of these additions and they are discussed in 3.2.

3. SUPPLY OF CONCRETE – BASIC REQUIREMENTS

3.1 CONTROL OF VOLUME

In Part III of this Guide it can be seen that concrete 'yield' is a key part of good mix design practice. AS 1379 details the methods of assessing the yield of concrete that can give some confidence in the mix design for the supplier. This method also gives some confidence that the customer is getting the volume of concrete that was ordered.

Because concrete is used to fill a certain 'mould' on site, it has always been ordered by volume. When concrete is batched this involves weighing up individual dry ingredients and sometimes weighing or measuring out liquid ingredients. The 'recipe' for these ingredients comes from a mix design and the concrete plastic density compared to the batched mass of ingredients per cubic metre gives the 'yield' (in batched cubic metres per actual cubic metres) of the concrete mix supplied.

The procedure for assessing a concrete mix yield as per AS 1379 is as given in the following steps:

1. Assess the mass of total ingredients in three batches of the concrete mix (kg);
2. For each batch of concrete carry out an assessment of the plastic density (mass per unit volume) of the mix using the method AS 1012.5;
3. Calculate the average plastic density (kg/m^3) from step 2;
4. Calculate the batch yield of each batch in step 1 by dividing its total mass by the average plastic density from step 3 (gives batch yield in m^3);
5. Calculate the mix yield of each batch in step 4 by dividing its batch yield by the volume of concrete specified in each of the three batches (gives yield in m^3/m^3 for each batch);
6. Provided the yield for each batch exceeds 98% then the correct volume has been delivered.

The aim of correct mix design is to achieve a yield of 100% on average but the reality is that batching accuracy and material changes may produce minor variations in apparent yield from batch to batch that is taken account of by allowing up to 2% in variation.

3.2 CONTROL OF ADDITIONS DURING DELIVERY

The most common addition to a concrete batch during delivery is water which is used to adjust the concrete slump where it is less than that specified. The addition of water to a mix specified by a characteristic strength or a maximum water/cement ratio needs to be carefully controlled to avoid non-conformances. While some specifiers rule out the addition of water to a batch after it leaves the concrete plant, AS 1379 does recognise the need for a limited ability to control the concrete batch slump on site. Common causes of this need can include higher ambient temperatures, delays in delivery due to traffic conditions, delays on site due to unforeseen site issues.

AS 1379 allows for various tolerances for each specified target slump as already discussed in Part VIII, Section 25 of this Guide. This Standard also allows the addition of water to a batch of concrete to maintain its slump within specified limits subject to a number of conditions that in summary ensure that:

- The addition of water does not cause the specified W/C ratio to be exceeded when applicable;
- Any water addition is recorded on the supplier's and customer's copy of the identification certificate;
- After any water addition the concrete will be fully mixed according to the Standard method;
- Where the batch is being tested for properties other than slump then the sample for these tests are taken after the addition of water.

AS 1379 also allows for additions of admixtures and additives on site provided these additions are approved by, and under the management of, the concrete supplier and dosed in

accordance with the additive supplier's recommendations. In this case the same conditions apply to such additions and their impact on the concrete batch slump (as applies to addition of water to correct slump for other reasons) as noted above.

Examples of additives and admixtures that may be added on site are:

- High Range Water Reducing admixtures with shorter slump retention periods;
- Some types of fibre reinforcement;
- Colouring additives.

3.3 CONTROL OF CONCRETE TEMPERATURE

As noted in sub-section 2.2, the ambient and concrete temperature can have a significant impact on concrete slump control and thus on mix water control.

The concrete supplier obviously can't control the ambient temperature during production and delivery but certainly can manage the concrete temperature during delivery using some of the methods discussed in Part V, Section 18 of this Guide.

AS 1379 provides guidance on the maximum and minimum concrete temperatures allowable during concrete supply. These are a minimum concrete temperature of 5°C and a maximum concrete temperature of 35°C. The Standard also notes that special care is required to manage the concrete when the ambient temperature is under 10°C or above 30°C.

Some specifiers link the concrete temperature to maximum allowable time for concrete delivery (time from starting mixing of the concrete to being placed in forms) in an effort to better control slump loss. Concrete delivery time is discussed in sub-section 3.4.

3.4 CONTROL OF THE DELIVERY TIME OF CONCRETE

AS 1379 sets a limit of 90 minutes for time from

commencement of mixing until the discharge of all concrete into forms. There is provision for the 90-minute limit to be varied by agreement, provided it can be shown that the concrete will retain the workability qualities on discharge (without the addition of excess water) and provide adequate time for placing, compaction and finishing.

The potential for a batch of concrete to be in workable condition after 90 minutes is dependent on the temperature of the concrete, the W/C ratio of the mix and the types of admixtures used. With higher concrete temperature and lower W/C ratio it is less likely that it will be possible to exceed 90 minutes of workable condition.

3.5 IDENTIFICATION OF DELIVERY

AS 1379 defines the Identification Certificate as being the equivalent of a delivery docket. It is required to provide a unique means of identifying the details of a batch of concrete. The certificate is required to contain the following information:

- Name of supplier, and place of manufacture;
- Serial number of certificate;
- Date of supply;
- Name of customer;
- Project name and location;
- Delivery vehicle identification, if applicable;
- Quantity of concrete covered by the certificate;
- Specified class and strength grade, or other mix identification;
- Specified slump, if applicable;
- Maximum nominal size of aggregate;
- Time of commencement of mixing;
- For concrete specified by water/cement ratio, the estimate of the quantity of water, if any, added after completion of batching and whether the addition occurred before, or after, commencement of discharge; or for concrete specified by slump, the estimate of water added after commencement of discharge;

- Any other detail that may be agreed between the customer and the supplier.

The certificate can perform an important part of both the concrete supplier's and the customer's quality management system. The serial number of the certificate also appears on testing certificates and is required to provide an audit trail to enable analysis of non-conforming concrete.

4. SPECIAL PROJECT DELIVERY REQUIREMENTS

4.1 SPECIALISED DELIVERY METHODS

Where very large volumes of concrete need to be placed on a single project, the method of transporting concrete to the construction site often needs to be reviewed. Managing traffic with large numbers of trucks moving on a site or coping with the problems of already congested public road access can lead to some innovative methods of increasing the reliability and volume rate of concrete supply. A few of these are discussed below.

Aircraft Pavement Supply

The construction of very large aircraft pavements has benefitted from the use of suitably designed 'slip-form' paving machines over many years (**Figure 10.2**). At optimum speed of placement, the paving machine may demand over 300 m³ per hour. In order to achieve this it has been found that a central mixer plant delivering full loads of concrete into tipper trucks provides the best speed of unloading and turnaround in front of the paving machine. This method provides significant challenges for the concrete producer to ensure they maintain the required consistency control for the concrete as well as meet the production and mixing capacity requirements.

This method of placing concrete road pavements has also become more common in recent years for the same reasons (refer to Part VI, Section 19 '*Slip-formed concrete*' for more information).



Figure 10.2 – Concrete Paving using a 'Slip-form' machine^{10.1}

Gravity Dam Concrete Supply

Concrete dam walls have been constructed from concrete for over a century. As the size of dams being constructed has increased with increasing pressure to shorten construction times, various innovative technologies have been developed. One of these is the use of 'Roller Compacted Concrete' (RCC) as the main volume of the dam wall structure.

Delivering large volumes of very low consistency concrete (usually zero slump concrete) into the construction zone can be achieved using 40-tonne dump trucks if accessibility is provided but also by mobile conveyor systems directly from the batch plant.

Pump to Site Concrete Supply

With the impacts of traffic congestion in large cities and the demand for large quantities of concrete to be supplied to major construction sites at all times of the day, the usage of a normal truck and transit mixer delivery system can become problematic.

One solution used over the years has been to set up an on-site concrete plant using truck and transit mixer to move concrete around the site. This can work where the access roadways and parking areas for trucks can be provided but this is often not possible.

An innovative solution that has been used in Australia has been using staged pumps through the site to pump the concrete directly from the on-site concrete plant to the various locations on site where concrete is required (**Figure 10.3**).



(a)



(b)

Figure 10.3 – ‘Pumped to Site’ Concrete Plant Setup and Overview of Site at Barangaroo South in Sydney, NSW^{10.2}

5. REFERENCES

- 1) AS 1379 – *Specification and supply of concrete* (R2017)
 - 2) AS 3600 – *Concrete structures* (2018)
 - 3) AS 1012 – *Methods of testing concrete*
-

End Notes

10.1 Photo adopted from 'WIRTGEN Slipform Paver, SP 1600', by Natalia Brandt, licensed under the Creative Commons Attribution-Share Alike 4.0 International license, https://commons.wikimedia.org/wiki/File:WIRTGEN_Slipform_Paver,_SP_1600.jpg

10.2 Photos Courtesy of Boral Limited

GUIDE TO CONCRETE CONSTRUCTION

T41



CEMENT CONCRETE
& AGGREGATES AUSTRALIA

PART V - Concreting Site Practices

CONTENTS

1. OUTLINE	2
2. DETAILING AND FABRICATION OF STEEL REINFORCEMENT	2
2.1 GENERAL	2
2.2 TOLERANCES FOR FABRICATION	4
3. FIXING STEEL REINFORCEMENT	4
3.1 GENERAL	4
3.2 HANDLING	4
3.3 POSITIONING	5
4. STEEL FIBRE REINFORCEMENT	7
4.1 GENERAL	7
5. PRESTRESSED CONCRETE	8
5.1 GENERAL	8
5.2 PRE-TENSIONING	8
5.3 POST-TENSIONING.....	8
5.4 APPLICATIONS.....	9
6. CONSTRUCTION USING PRESTRESSING	10
6.1 PRESTRESSING SYSTEMS	10
6.2 FIXING DUCTS AND ANCHORAGES	10
6.3 PLACING AND COMPACTING CONCRETE	11
6.4 STRESSING.....	11
6.5 GROUTING	12
6.6 SAFETY	13
7. ADDENDUM: SAFETY PRECAUTIONS FOR PRESTRESSING OPERATIONS 14	
7.1 INTRODUCTION	14
7.2 PRECAUTIONS TAKEN BEFORE STRESSING.....	14
7.3 PRECAUTIONS TAKEN DURING STRESSING.....	15
8 REFERENCES	17

1. OUTLINE

This section provides information on the types of steel reinforcement used in Australia (including steel fibres), and guidance on its detailing, handling and fixing.

Also provided is guidance on the fabrication and fixing methods for prestressing steel as well as the techniques used to tension the steel tendons and to bond them into the concrete.

2. DETAILING AND FABRICATION OF STEEL REINFORCEMENT

2.1 GENERAL

The detailing and fabrication of reinforcement, within the tolerances specified for the project, are two of the most important facets of concrete construction.

Reinforcement is placed in concrete members to resist the stresses in the member that result from the loads imposed on it. The designer calculates the magnitude of the stresses and then determines both the amount and the position of the reinforcement required. If the structure is to perform as intended then the appropriate shape, strength grade, ductility class and size of reinforcement must be chosen, fabricated, fixed and surrounded by concrete as shown in the drawings.

Detailing

Detailing is considered to be the preparation of working drawings showing the size and location of the reinforcement used in all of the concrete structural elements that form the whole structure.

Good detailing ensures that reinforcement and concrete interact efficiently to provide satisfactory behaviour of the reinforced concrete structure under all loading conditions.

Good detailing also ensures that the constructability of the structural elements (e.g. spacing between bars to allow full compaction of concrete) is taken into account as well as it being an economical design.

The end product for the detailer is a set of drawings that provides the required details for

the building contractor, steel fixer and the scheduler.

Scheduling

The first step in the fabrication of reinforcement is the preparation of a schedule which lists each individual bar profile or sheet of mesh required for the job. This will show:

- The profile, strength grade, ductility class and size of reinforcement for each item;
- The profile and dimensions of each item;
- The number of identical items;
- Identifying numbers or positions; and
- The total mass of steel reinforcement.

It is prepared by a scheduler from the structural drawings and other instructions. From this schedule, the reinforcement supplier will cut and bend reinforcement for delivery to the site.

Cutting

Straight bars are cut normally by shearing, which may slightly distort the end of the bar. If undistorted, square ends are required for items such as dowels for use in movement joints, friction cutting or sawing is preferred.

Where mesh is required in sheets less than the standard 6 m length, the mesh is cut and trimmed on site with bolt cutters, oxy-acetylene equipment or angle grinders.

Bending

Reinforcement may need to be bent during fabrication to accommodate it within the shape of the concrete member to provide anchorage. Bending may be carried out while the reinforcement is at normal temperatures, or whilst it is hot, at temperatures up to 600°C.

Heating of the steel is permissible provided the temperature is not allowed to exceed 600°C as an absolute maximum. If the temperature exceeds 450°C, the bars are downgraded, and the maximum strength is taken as Grade 250.

When reinforcement is bent at normal temperatures it loses a certain amount of its ductility, or it becomes more brittle. When steel is overstressed during bending operations, or is rebent, further reducing its ductility, it may become subject to 'brittle failure', where a sudden fracture of the steel under load occurs.

To prevent such brittle failures and to avoid overstressing of the concrete inside the bends, AS 3600 specifies minimum diameters for bends in bars of different strength grades to be used in different situations.

These recommendations are shown in **Table 11.1** and actually take the form of recommended minimum diameters for the pins around which the steel is bent during fabrication and take into account:

- The strength grade of steel;
- The diameter of the bar;
- The purpose of the reinforcement;
- The possibility of rebending; and
- Whether or not the bar is coated.

Typical pin diameters range from three times the diameter of wire or bars to be used in fitments to eight times the diameter of coated bars 20 mm in diameter or greater.

The recommendations set out in AS 3600 on the bending of reinforcement are formulated for bars complying with AS/NZS 4671. Steels not complying with this specification, e.g. some steels manufactured overseas, may be damaged by bending to the diameters recommended. In this context, it should also be noted that bending deformed bars over a diameter pin that is too small can also damage the bar. The deformations themselves may be crushed, causing minute cracks which act as stress initiators during subsequent bending operations.

Rebending

Although in principle the rebending of reinforcement is undesirable because of the reduction in its ductility, occasions do arise on site where some rebending is unavoidable. In all such cases, the proper equipment should be used. Bending with the aid of a pipe and/or sledgehammer is not acceptable.

For larger diameter bars, heating may be the only solution. In such cases, the temperature of the bar should be checked with the heat-indicating crayons normally used for welding, to ensure that the maximum permissible temperatures are not exceeded. If exceeded, AS 3600 requires the allowable stress in the steel to be drastically reduced. Heating of

reinforcing steel on site should therefore never be undertaken without the approval of the design engineer.

Table 11.1 – Minimum Pin Diameters for Cold-bending Reinforcement (from Clause 17.2.3.3 of AS 3600)

Reinforcement	Minimum pin diameter – $d_b = \text{bar diameter (mm)}$
Fitments:	
– Grade 500L bars (mesh) and R250N bars	3 d_b
– Grade D500N bars	4 d_b
Reinforcement other than galvanised or epoxy coated, and which is not intended to be rebent	5 d_b
Galvanised or epoxy-coated reinforcement	
– 16 mm diameter or less	5 d_b
– 20 mm diameter or greater	8 d_b
Reinforcement that is intended to be straightened or rebent	
– 16 mm diameter or less	4 d_b
– 20 mm or 24 mm diameter	5 d_b
– 28 mm diameter or greater	6 d_b

2.2 TOLERANCES FOR FABRICATION

Tolerances on the fabrication of reinforcement stipulated in Clause 17.2.2 of AS 3600 are shown in **Table 11.2**. Maintenance of these is necessary, firstly to ensure that when fabricated, the reinforcement will fit within the mould or formwork for which it is intended; but secondly, and most importantly, that the concrete cover necessary to protect the reinforcement from the environment is maintained. Thus, it will be noted that

reinforcement and fitments must not be longer than specified.

Table 11.2 – Tolerances for Fabricating Reinforcement (from Clause 17.2.2 of AS 3600)

Item	Tolerance
Fitments – on any overall dimension of bars or mesh	
– For deformed bars and mesh	–15, +0 mm
– For plain round bars and wire	–10, +0 mm
Reinforcement – on any overall dimension of bars or mesh	
– For lengths up to 600 mm	–25, +0 mm
– For lengths over 600 mm	–40, +0 mm
Cranked column bars	
– Overall offset	–0, +10 mm
End-bearing splices	
– Angular deviation from square for a sawn or machined end relative to the end 300 mm	2°

3. FIXING STEEL REINFORCEMENT

3.1 GENERAL

The position of the reinforcement may well be more important than the amount. For example, reinforcement specified to be placed in the top of a multi-span beam or slab, to resist the tension over intermediate supports, will be totally ineffective if placed in the bottom of the beam or slab.

Reinforcement also requires a minimum amount of cover to protect it from the effects of fire and/or from an environment that may cause it to rust and corrode. The tolerances specified for the fixing of reinforcement are designed to ensure that these minimum requirements are met.

3.2 HANDLING

Reinforcement should be checked for loose scale, mud and oil.

Loose scale is normally removed as the bars are handled in the fabricating factory, or during loading and unloading, and it is not usually necessary to carry out any special 'cleaning' procedure to remove it. Mill scale and light rust are generally thought to have little effect on bond. Indeed, moderate rusting is thought to improve bond.

Mud and dirt should be washed off before the bars are placed in the forms as they could be detrimental to bond and to the quality of the concrete.

Oil and grease should also be removed (with solvents) and care taken that bars do not become coated with form oil during fixing operations.

3.3 POSITIONING

General

It is essential that reinforcement be fixed in the position specified by the designer in the structural drawings. If it is not, then the structural performance, durability or fire resistance (perhaps all three) could be seriously impaired. Reference should be made to the placement tolerance set out in Clause 17.5.3 of AS 3600.

A number of methods are used to locate reinforcement correctly. These are discussed in the following sub-sections.

Bar Chairs

Bar chairs are generally used to support bar or mesh reinforcement above horizontal surfaces. They are available in a variety of shapes and may be made from wire, plastic or concrete. All bar chairs must comply with AS/NZS 2425.

They are also manufactured in a range of sizes, each of which provides a specific thickness of concrete cover. Indeed, some are manufactured so that different thicknesses of cover may be achieved with a single unit. Typical are concrete blocks which can be used with different faces uppermost and plastic chairs which can be positioned in a number of different ways. A range of bar chairs is illustrated in **Figure 11.1**.

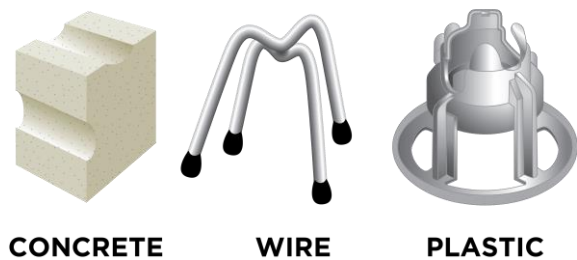

CONCRETE WIRE PLASTIC

Figure 11.1 – Typical Bar Chairs

Factors which should be considered in the choice of a bar chair appropriate to the work in hand include:

Cover: A bar chair should be selected to provide the correct cover – not one 'close-to' that required. In using a multi-cover chair, care must be taken that it is positioned correctly.

Strength: Bar chairs have a load rating of 60 kg, 120 kg, 200 kg, 300 kg or more. It is important that the strength of the bar chairs be specified.

Type of bar chair: It is important that the type of bar chair (steel, concrete or plastic) is selected for exposure conditions of the concrete structure. For example, using an un-protected steel bar chair in a suspended slab with an exposed soffit could mean that the bar chair itself will corrode, producing staining and spalling of the concrete even though the reinforcement is correctly located.

Appearance: Where the soffit is exposed, the tips of the bar chairs may be seen. It is necessary, therefore, to consider the appearance of the completed element in choosing a suitable support for reinforcement.

Membrane damage: Bar chairs which could puncture damp-proof membranes during placing operations should be avoided or supported on purpose-made 'saucers'.

Stability: Some types of bar chairs are easily displaced or knocked over during concrete-placing operations. Selection should ensure that the risk of this is minimised.

Spacing of bar chairs: Combined with the strength, the spacing ensures that the weight of reinforcement, construction equipment and personnel can be supported. It also ensures that the deflection of reinforcement is limited and helps ensure that the required concrete

cover is maintained. The required spacing will depend on the concrete placing method and the grade/size of reinforcement. Thus, the minimum spacing will range from 0.5 m to 1.0 m.

Spacers

Spacers that snap onto reinforcing bars are available to maintain the required distance from the bar to the face of the concrete. They are generally made of plastic. As for chairs, spacers must conform with AS/NZS 2425 and the selection and positioning of spacers must always be such as to ensure that the reinforcement is correctly positioned and that the surface appearance of the concrete is acceptable.

Tying

Reinforcing bars may be tied together, or to fitments, to form a 'cage' which helps maintain the bars in position during the subsequent concreting operations. Obviously, the cage must be strong enough to achieve this – sufficient fitments must be used for this purpose (**Figure 11.2**).



Figure 11.2 – Reinforcement being tied in Position

The most common tie material is a black annealed wire, 1.6 mm in diameter, although other forms of wire and plastic clips are available.

It is not necessary to tie bars at every intersection as ties add nothing to the ultimate strength of the structure. They serve only to keep the reinforcement in place during concreting. Nevertheless, it is better to provide too many than too few, particularly at the edge of slabs, around openings, at corners, and in

similar locations where positioning of the reinforcement is particularly critical.

Welding

Reinforcing steel should not be welded except with the approval of the engineer. Such welding must then comply with AS/NZS 1554.3.

The locational welding of main bars into the corner of fitments may be approved but other welding should not be carried out within 75 mm of any bend of a radius less than eight times the bar size.

Splicing Reinforcement

Lengths of reinforcing bar or mesh may be joined or 'spliced' together in a variety of ways.

The most common method is simply to lap the bars or mesh. The lapped portion of the bars or mesh must always be in contact unless otherwise indicated on the drawings.

When mesh is lapped, the two outermost wires of one sheet must overlap the two outermost wires of the other. Meshes are available with the edge wires spaced closer together, thus reducing the area of the lapped zone and increasing the coverage of the sheet.

A variety of proprietary mechanical splices are also available for joining bars. These have different applications, advantages and disadvantages. It is vital, therefore, that the correct type of splice is used in any given situation and that the manufacturer's instructions on installation are followed.

Tolerances

A tolerance provides an acceptable allowance for small variations to the specified length or position of reinforcement. For reasons that include structural performance, durability and fire resistance, reinforcement must be in the position intended for it within an appropriate tolerance.

Tolerances for the positioning of reinforcement and tendons stipulated in Clause 17.5.3 of AS 3600 are shown in **Table 11.3**. Knowledge of these tolerances is essential for all those concerned with the fixing or checking of reinforcing.

4. STEEL FIBRE REINFORCEMENT

4.1 GENERAL

Section 7 of this guide has discussed the properties of steel fibres used in concrete. In this section the methods for dosing steel fibres into a concrete mix are also discussed. The aim of mixing fibres in concrete is that the end product has a uniform distribution of fibres in accordance with the mix design dose rate. There are some steps necessary to achieve this uniform distribution and further to that there are test methods used on the mixed concrete that can be used to verify that distribution.

Mixing Steel Fibres in Concrete

ACI 544.3R provides guidance on mixing of steel fibres into concrete. Loose steel fibres with higher aspect ratio (length to diameter ratio) are prone to what is referred to as ‘balling’ or binding together due to frictional effects between fibres. Once formed this ‘ball of fibres’ will be difficult to break up in the plastic concrete mix. If a number of these balls of fibres form during batching, then the concrete mix will not have the uniform distribution of fibres expected in the concrete mix.

Two methods are recommended to overcome this tendency to form fibre balls:

- One method is offered by some steel fibre manufacturers where the fibres are bonded together in groups of 20 or more fibres using water soluble glue. This prevents the fibres from balling and makes loading into the concrete mix a simpler process. The glue dissolves in the presence of mix water and the fibres distribute during mixing;
- The other method used is to load fibres through a screen sized to break up any balls of fibres before being loaded into the mixer via a conveyor. This is more effective if the rate of addition of fibres is reduced to avoid heaping of fibres on the conveyor.

Table 11.3 – Tolerances on Position of Reinforcement and Tendons (from Clause 17.5.3 of AS 3600)

Item	Deviation from specified position
For positions controlled by cover:	
– In beams, slabs, columns and walls	–5, +10 mm
– In slabs-on-ground	–10, +20 mm
– In footings cast in the ground	–10, +40 mm
<i>(where a positive value indicates the amount the cover may increase and a negative value indicates the amount the cover may decrease)</i>	
For positions not controlled by cover:	
– The location of tendons on a profile	5 mm
– The position of the ends of reinforcement	50 mm
– The spacing of bars in walls and slabs and of fitments in beams and columns	10% of the specified spacing or 15 mm, whichever is greater

In general, it is recommended that total mixing times for concrete containing steel fibres are extended by at least 30% to allow for loading and mixing the fibres through the plastic concrete. Batching equipment for weighing and delivering fibres to the mixer is a recent development towards safe and controlled addition of fibres to the concrete mixer where larger volumes of fibre concrete are being produced.

Testing Steel Fibre Distribution in Concrete

As well as the standard tests used for normal class concrete there are tests for the uniformity of fibre addition to concrete. One such method

is VicRoads Test Method RC 377.01 'Determination of the Fibre Content of Fresh Concrete (Wash-out Method)'. The aim of the test is to assess the average content and the variability in measured fibre content (in kg/m³) between three samples of the same batch of concrete. Generally, a tolerance on individual test samples is specified as well as the average. For example, a target dose of 30 kg/m³ of a steel fibre may allow a minimum test sample value to be 22.5 kg/m³ and minimum average of three samples to be 26 kg/m³.

5. PRESTRESSED CONCRETE

5.1 GENERAL

There are two common systems used for constructing prestressed concrete structures. These systems are:

- Pre-tensioning;
- Post-tensioning.

These systems are discussed in the following sections.

5.2 PRE-TENSIONING

In a pre-tensioned member, tendons are first carefully positioned within the formwork and the design load or tension applied to them. Then, while tensioned, the concrete is cast around them and allowed to harden until it achieves sufficient strength (usually above 30 MPa) to resist the forces to be applied to it. The ends of the steel tendons are then released from their restraints and the stress in them is transferred to the concrete by the bond between the two materials.

The tendons used in pre-tensioning are usually in the form of small-diameter wires or strands (a combination of smaller wires). The diameters of these materials are kept small to increase the surface area available for bonding with the concrete. Crimped or indented wire is also commonly used to further increase bond (**Figure 11.3**).

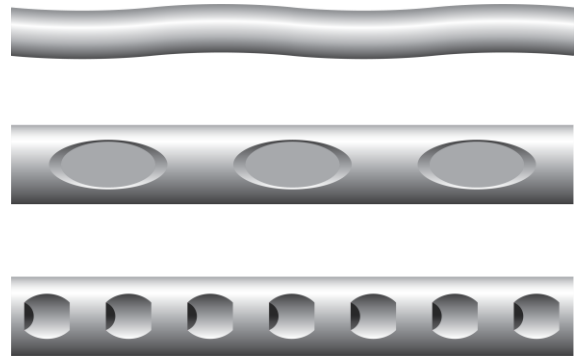

Figure 11.3 -Crimped or Indented Wire

5.3 POST-TENSIONING

When a member is to be post-tensioned, the concrete is first allowed to harden before the steel tendons are stretched or tensioned. They cannot therefore be allowed to bond with the concrete, at least not initially. Usually they are placed in ducts or holes that have been cast in the concrete, although sometimes they are greased and sheathed in plastic to prevent bond. In other cases, the tendons are fixed to the outside faces of the member.

After the concrete has gained sufficient strength, the tendons are tensioned and then fixed or anchored in special fittings cast into the ends of the concrete member. A wide variety of patented fittings and systems are available for this purpose. Typical slab and beam anchorages are shown in **Figures 11.4** and **11.5** respectively. The ducts are then filled with a cement grout which, when set, bonds the tendons to the concrete.



Figure 11.4- Typical Slab Anchorage

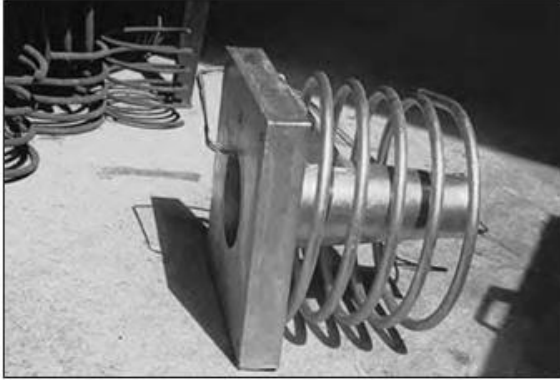

Figure 11.5 – Typical Beam Anchorage

5.4 APPLICATIONS

Although both pre-tensioning and post-tensioning systems are designed to apply prestress to concrete members, there are some practical differences in their fields of application. Thus, pre-tensioning is normally confined to the factory production of repetitive precast concrete units where the cost of the relatively large abutments or restraints, against which the prestressing jacks operate, can be justified. Alternatively, very strong and robust formwork may be constructed, and wires anchored against its ends.

Post-tensioning is more flexible in its application and may be carried out onsite. It permits the use of curved tendon profiles and is also suited to a wide variety of construction techniques, such as 'segmental construction' and 'stage stressing'. Since stressing is not carried out until the concrete has hardened, the concrete member itself provides the restraint against which the stressing jack operates (Figure 11.6).



Figure 11.6 – Post-tensioning Jack operating on End of Concrete Girder

An example of a prestressed concrete bridge is shown in Figure 11.7.



Figure 11.7 – Multi-strand, Post-tensioned bridge, Mooney Mooney, NSW

Ducts

Ducts can be formed in concrete by casting in a flexible metal or plastic tube, by using an inflatable rubber tube or by using a removable steel former.

The use of a flexible metal tube is the most common method of forming a duct. The tubes are relatively thin yet can withstand onsite handling. Normally, tendons are cut to length and 'pulled through' or 'pushed into' the duct (i.e. positioned within it) prior to concrete being cast. This helps to locate and restrain the duct during concrete placing and avoids the major problem of trying to thread the tendons through the duct should it be damaged.

Where it is not possible to place the tendon in the duct prior to concreting, the duct may be held in position with a plastic tube, an inflatable rubber duct or a bundle of wires. Straight ducts can also be located with the aid of a slightly undersize steel tube.

Inflatable rubber formers should be supported and inflated to the manufacturer's instructions. They will normally require support at 300 mm centres and be inflated to about 200 kPa. When rubber formers are used in steam-cured concrete, care should be taken to ensure that the heat does not increase the pressure in the tube by an unacceptable amount. Rubber formers are usually deflated in steps and withdrawn immediately when the concrete has

set and begun to harden, e.g. after about four hours from casting the concrete.

The use of removable steel formers is a somewhat risky procedure and is therefore normally limited to small lengths. Greasing of the tubes to prevent bonding with the concrete can interfere with subsequent bonding of the grout.

Anchorage

Anchorage comprise units or components which enable the tendon to be stressed, and then transfer the force in the stressed tendon to the concrete member or structure. They also commonly incorporate facilities to enable the ducts to be injected with a cement grout to protect the tendons from corrosion and bond them to the concrete.

6. CONSTRUCTION USING PRESTRESSING

6.1 PRESTRESSING SYSTEMS

Prestressing systems may be loosely described as the combination of methods and equipment that are used to tension the tendons and then to fix them so that they transfer their load to the concrete. They therefore include not only the anchorages, and in some cases, the tendons, but also the jacks which are used to stretch the tendons.

It is beyond the scope of this Guide to provide information on the many and varied systems which are used in Australia with most being patented. The manufacturers and/or suppliers should be contacted for details of these systems.

6.2 FIXING DUCTS AND ANCHORAGES

The correct placement of ducts within the formwork and securing them against movement during concreting are very important steps in prestressed concrete construction. In post-tensioned construction, tendons are very often draped or profiled within the member in order to obtain the maximum benefit from the prestress. This tendon profile, as it is known, is an important feature of prestressed design and

any significant deviation from it may cause the member to deflect or behave in a way not anticipated in the design.

The importance of the tendon profile is recognised by AS 3600 which requires that the profile be maintained within 5 mm of that specified.

In positioning ducts, it is important to remember that the centreline of the duct will not coincide with the centreline of the tendon. With draped cables, the tendons, when tensioned, will bear against the top of the duct in the centre of a span, and with continuous cables, on the bottom of the duct over the supports.

In positioning and securing ducts within the formwork, care must be taken, therefore, that the profile is maintained (**Figure 11.8**). This is achieved by tying the duct to the reinforcing steel, chairs, or other supports. The fixings should be sufficiently rigid, and at sufficiently close centres, to prevent displacement of the duct during the concrete operation. Small ducts should be supported at about 1 m centres. Supports for large ducts, which naturally maintain an approximately correct profile due to the stiffness of the duct, should be 3 m or less, depending on the duct stiffness. In addition to displacements likely to be caused by the weight of concrete and the operation of the vibrator, displacement can occur due to flotation of the ducts. Fixing should prevent this from occurring.



Figure 11.8 – Positioning the Ducts in the Formwork

Particular care is necessary to ensure that the ducts are correctly located adjacent to the anchorages so that unintentional angular deviations do not occur. Un-tensioned reinforcement, particularly beam stirrups and

end-zone reinforcement should have been detailed carefully by the designer to ensure the ease, accuracy and quality of duct placement.

Fabrication and placement details for anchorages are normally provided by the supplier and should include such details as anchorage block out dimensions, bolt hole dimensions, clearance requirements for stressing equipment etc.

Anchorage must be fixed to prevent movement during concreting. In cases where anchorages are attached to the end formwork, the latter must be sufficiently rigid to withstand the horizontal forces which can be imposed on the anchorages during the concreting operation, and the fixing detail should be such that the ingress of grout at this point is prevented.

6.3 PLACING AND COMPACTING CONCRETE

The concrete placing and compaction programme should be prepared in good time and must be carried out with the greatest possible care since defects in concreting are liable to cause problems during the stressing operation.

Just prior to placing concrete, the tendons and anchorages should be inspected carefully to ensure they are securely tied at all locations and that there is no possibility of mortar leaking into the duct or anchorage device during placing and compaction of the concrete.

Proper tendon alignment must be maintained ahead of the concrete placement and care taken to ensure that ductwork is not damaged. Ducts should not be stepped on nor damaged with vibrators.

If the duct is damaged, repairs should be made to prevent concrete from bonding to the tendons. Small holes can be repaired by using waterproof adhesive tapes. Larger holes should be covered by metal strips wrapped around the duct. The overlap should be at least 100 mm and the joints should be sealed by a waterproof adhesive tape.

Particular care should be taken at the end-zone and at grout pipes, air bleeds and reinforcement to ensure uniform compaction and to avoid unnecessary voids.

Immediately after concreting, where possible, cables should be pulled back and forth to ensure that they remain free.

6.4 STRESSING

The majority of stressing systems use hydraulic jacks to tension the steel tendons which may be tensioned singly or in groups. Jacks capable of exerting forces of up to 1,800 tonnes have been developed for stressing operations in large dams and similar applications but on most construction-sites jacks with capacities up to 300 tonnes would be employed (**Figure 11.9**).



Figure 11.9 – Typical Hydraulic Jack (with hydraulic hoses from compressor unit foreground)

In single-tendon stressing, each tendon is individually stressed. In multiple stressing, all the tendons in the duct are stressed at the same time. The smaller jacks used for single pulling allow easier jack handling, but the number of operations is increased. The large

jacks used in multiple stressing reduce the number of stressing operations but may require mechanical handling. The type of jack employed must correspond to the prestressing system used and to the dimensions of the tendons. This must always be checked as must the stroke of the jack to ensure it is appropriate to the job. Stressing operations are carried out by crews specially trained in the use of the particular type of equipment used.

The time and sequence of stressing is determined by the designer to achieve the following objectives:

- Early partial stressing to minimise the development of shrinkage cracks. Typically stressing at 24 hours after casting;
- Early partial stressing to balance the self-weight of the slab and to enable formwork to be more economically used. For multi-storey construction, the early capacity to support subsequent floors is a primary consideration;
- The proper stressing sequence to avoid large differential stresses in adjacent cables or areas;
- In stage prestressing, to balance the loads being applied as the structure progresses.

The measurement of stressing load is usually based on load cells or dynamometers, confirmed by measurement of the elongation in the tension cable. Readings of extensions should be made with an accuracy of 1 mm. The first increment, which removes slack, will normally be 10-20% of the final jacking force. At this stage, the zero-reading for extensions are usually made.

The theoretical extension takes into account the tendon profile and friction.

After stressing has been completed, the tendons are anchored in accordance with the standard procedure of the prestressing system.

All data observed during the stressing operations should be recorded immediately in the stressing log. As these are the only available evidence of the required prestressing force having been reached, they should be

signed by the person responsible for the stressing and kept in a safe place. The figures in the stressing log should take into account adjustments for zero readings and the elongation of tendons beyond the anchorages.

The load/elongation measurements provide vital information on the prestressing force obtained and on possibly significant deviations from the design assumptions. Meticulous stressing records are essential for a complete evaluation of the quality of the work. Before the stressing log is submitted to the designer the recorded extensions should be checked for any inconsistency. Two ducts with the same number of tendons, same drape and same stressing force should not have extensions varying by more than about 5%. Any inconsistencies should be investigated in consultation with the designer.

Tendons should not be cut or grouted and should be kept in such condition that they can be re-stressed until permission for work to proceed has been granted by the designer.

Because the measurements during stressing are influenced by random factors, acceptable limits for the difference between calculated and observed values should be stated by the designer. Where tolerance in extensions has not been specified, a realistic value may be taken as $\pm 5\%$ to $\pm 10\%$.

6.5 GROUTING

In Australia, post-tensioned tendons are usually grouted in their ducts after the stressing operations for the following reasons:

- A reliable bond between the stressed tendon and the concrete member is established (in addition to the end anchorages);
- Should unforeseen circumstances cause the ultimate strength of a member to be exceeded; a properly designed member with bonded tendons will develop many distributed small cracks and fail in a ductile manner;
- The best protection the tendon can have is to be surrounded by cement-rich grout or concrete that is well compacted and

impermeable. Steel cannot corrode in an alkaline environment except when chlorides are present. This is why the chloride content of prestressed concrete may be specified at a level below that of normal class concrete in AS 1379.

Grouting should be carried out as soon as possible after stressing. However, the tendons must not be cut, nor must the duct be grouted until final approval of the stressing has been given. Grouting should generally not be delayed for more than seven days unless special precautions are taken. The period should be shorter in cases with aggressive environments.

Specification of the grouting procedure is essential to successful grouting and should address such items as grout composition and properties, duct soundness (i.e. there should be no obstacles or grout paths between ducts), grouting sequence, grouting pressure and rate, venting, volume checks, re-grouting or topping up, communication between operators at duct inlets and outlets, and safety.

Before grouting, the duct may be tested for blockages by means of compressed air (not preferred) or water. Connections for the grout hose to the duct should be free from concrete, dirt, etc. and vents should be inspected to make certain that they can be properly closed.

In cold climates, precautions should be taken to prevent the freezing of water in the un-grouted duct. After a period of frost, care must be taken that the duct and tendon are free from ice.

All grout used for the grouting of prestressing ducts should consist of Portland cement and water and specialised admixtures. Admixtures should be free from any product liable to damage the steel or the grout itself, such as chlorides, nitrates and sulfides.

The grout is generally tested for strength, fluidity and resistance to segregation. Suitable test methods are found in AS 1012.8.3, AS 1012.9, ASTM C939 and ASTM C1741 respectively.

Grouting records should be kept for each cable, and should contain itemised information on grout properties, pump pressures, volumes, rate of progress and environmental conditions.

The approval of the grouting for cables or groups of cables should be clearly marked by authorised signatures on record sheets.

From time-to-time difficulty may be experienced in grouting, due to such problems as the grout being improperly mixed or proportioned, improper flushing prior to injection or unintended obstructions in the post-tensioning ducts. The result is that one or more tendons may become partially grouted. In order to salvage members with problems such as these, holes must be drilled into the post-tensioning duct with great care in order to not damage the tendons. The extent of the grouting or the location of possible obstructions can thus be observed. After this has been done, the ducts should be flushed with lime water and the tendons grouted, using the drilled holes as ports. Alternatively, vacuum-assisted methods can be used. This is a specialised operation to be undertaken only by skilled crews in conjunction with the designer.

6.6 SAFETY

Prestressing involves the use of very large forces and high pressures in the hydraulic pipelines. Appropriate precautions must be taken to prevent accidents as these can have very serious consequences.

A number of organisations have prepared recommendations on safety precautions during stressing. These include:

- FIB report: *'Prestressed concrete: safety precautions in post-tensioning'*, Thomas Telford, London (1989);
- *'Safety Precautions for Prestressing Operations (Post-Tensioning)'*, The Concrete Society, London (1980);
- *AS 1481 – Prestressed Concrete Code* (superseded), Standards Australia (1987);
- *'Code of Practice'*, Work-cover NSW (1993);
- *'Stress Safe, Stress Smart – Prestressing of Concrete Structures'* (video), available from the major post-tensioning companies.

7. ADDENDUM: SAFETY PRECAUTIONS FOR PRESTRESSING OPERATIONS

7.1 INTRODUCTION

This addendum is reproduced from Appendix B to the superseded AS 1481 'Prestressed Concrete Code' and provided for guidance.

The purpose of this addendum (notes) is to state some simple but sensible precautions to ensure that stressing is carried out with the maximum consideration of important safety factors. The operations involved in tensioning and de-tensioning prestressing tendons are not dangerous – as long as sufficient care is taken. The main problems are ignorance, lack of thought, and over-familiarity.

These notes have been based on successful experience over many years and are intended for use by the supervising engineer or supervisor in charge of stressing.

The following assumptions have been made:

- Stressing operations will be carried out by experienced personnel under a competent supervisor;
- The design and construction of the units concerned is of the required high standard;
- All equipment is in full working order and properly maintained.

7.2 PRECAUTIONS TAKEN BEFORE STRESSING

General

- Ensure that sightseers are kept away from stressing operations;
- Erect stout double-faced screens at the back of the jack to form a safety barrier;
- Display a large sign, 'ATTENTION – STRESSING IN PROGRESS – KEEP CLEAR', on the outside face of the safety screen to warn workmen and passers-by;
- Fence off the area between the safety screens and the unit being stressed, so that no one can pass between them during the stressing operations;
- Always refer to the supplier's detailed instructions for the equipment being

used, and follow these instructions carefully;

- Check all equipment before use and report any signs of wear or defects;
- Instruct all operatives and supervisors to wear safety helmets during stressing operations;
- Display a notice adjacent to the stressing plant, giving the maximum design load of the bed and the upper limit of the position of the centre of gravity of the stressing wires;
- Ensure that adequate precautions have been taken to restrain any possible skewing or lifting of the stressing equipment during stressing or release;
- Do not permit any welding near high-tensile prestressing steel;
- Do not permit any prestressing steel to be used for earthing electrical equipment of any kind;
- Keep all equipment thoroughly clean and in a workmanlike condition (as badly maintained equipment always gives rise to trouble and consequently is dangerous).

Handling of Materials and Equipment

- Make sure that operatives wear gloves when handling prestressing tendons;
- Temporarily suspend any other construction operations which might require a workman to stand directly behind the jack during stressing;
- Be careful when handling coils of high-tensile wire or strand as these may whip back with force if not securely bound;
- When assembling tendons, check each individual wire or strand for obvious flaws;
- Do not allow grips to be exposed to the weather and become rusty;
- See that wedges and the inside surfaces of anchorages are clean so that the wedges are free to move inside;
- Ensure that the threads of bars, nuts and couplers are cleaned and oiled, and thread-protecting wrappings removed only at the last moment before use. (Threaded bars for pre-formed ducts must have suitable protection to the thread to avoid damage by abrasion.);

- Arrange for stressing to take place as soon as possible after the grips have been positioned.

7.3 PRECAUTIONS TAKEN DURING STRESSING

Using a Prestressing Jack

- NEVER STAND BEHIND A JACK DURING STRESSING OPERATIONS;
- Do not allow operatives to become casual because they have stressed hundreds of tendons successfully before. (The forces they are handling are enormous and carelessness may lead to loss of life.);
- Regularly examine hydraulic hoses as a matter of necessity, and likewise regularly drain and filter oil in the pump reservoir;
- Use only self-sealing couplings for hydraulic pressure pipes, and take particular care that no bending stresses are applied to end connections;
- Whenever possible, use only hydraulic equipment supplied with a bypass valve that is pre-set to a maximum safety load before stressing. (The maximum safety load should not be more than 90 percent of the minimum specified ultimate strength of the tendons.);
- Check hydraulic pressure pipes for flaws or bubbles after each stressing operation;
- Double-check the grips or fixing of tendons to the prestressing jack before stressing;
- Keep the wedges clean and free from dirt, remembering that wedge teeth do not last forever;
- In systems where more than one wire or strand is gripped at a time around the body of the jack, make sure the wedge pieces are not worn. (A slip of one wire or strand may well cause overloading on the others, which may lead to failure.);
- Tension tendons to a low initial stress (say 62 MPa), and then recheck wedges, fixings and position of jack, and set the extension gauge to zero at this stage;

- Do not strike the equipment with a hammer to adjust the alignment of the jack when the load is on;
- Check the fixings at the non-jacking end;
- Ensure that a competent person is always available at the non-jacking end to check on anchorages during stressing;
- Double-check tendon fixings before releasing tensions.

Pre-Tensioning

- NEVER STAND BEHIND A JACK DURING STRESSING OPERATIONS;
- Pin-up the top wires or strands before the others, and on completion check that they have been pulled straight and are not tangled or caught up in the forms. (Pinning-up refers to the initial pull in a tendon before marking for measurement of elongation.);
NOTE: A pinning-up force of 2.2 kN is recommended for wire of 5 mm diameter, and a force of 4.4 kN for a strand of 12.5 mm diameter. This should be enough loading to free any tangles and clear obstructions.
- Before tensioning, ensure that all the wires or strands are secured against the possibility of flying loose, and regard the following as safeguards:
 - i. Shutters and end-plates;
 - ii. Hoops and stirrups enclosing tendons;
 - iii. Heavy timbers laid over tendons;
 - iv. Rolls of hessian laid across tendons.
- Insist that during stressing operations all personnel must stand clear;
- Insist that the operator, when stressing strands singly, must not stand directly behind grips that have recently been tensioned;
- *Stressing, multi-wire or multi-strand:* When stressing multi-wire or multi-strand, apply a small extension initially and check the line to ensure that there are no loose or caught-up wires or end-plates, and only after this inspection should the full load be applied;
- In placing the packers, take care not to score the ram of the jack;
- *Stressing, single wires or single strands:* When stressing single wires or single strands, apply the full load and

extensions to each of the wires or strands and then lock-off. The loads and extensions should then be carefully noted by the supervisor;

- Place a protective guard over the grips before starting multi-strand stressing, and immediately after single-strand stressing is completed.

Post-tensioning

- After stressing, cut off wires or strands behind the anchorages, preferably with a disc cutting tool, a cropper or a snapping-off tool;
- Ensure that a clear eye shield is worn by operatives during grouting operations;
- Before grouting, check all ducts to make sure that none are blocked;
- If possible, use only threaded connectors between grout nozzles and grouting points. (A sudden spurt of grout under pressure can cause severe injury, especially to the eyes.);
- Do not peer into duct bleeders to see if grout is coming through. (Grout may jam temporarily and, as pressure is applied, may spurt suddenly from the bleeders, or the far end of the duct, causing serious injury.);
- When grouting over railways or public roads or other public places, take precautions to see that escaping grout does not cause a hazard to traffic below.

De-tensioning

- Before de-tensioning, remove all obstructions to the free movement of the units;
- Allow the crosshead to be jacked back by only the small amount that is just sufficient to free the packers;
- De-tension slowly and evenly, as any sudden movement may cause damage to the concrete units;
- If the tendons are de-tensioned one at a time, do this in the required sequence;
- Ensure that the supervisor keeps a record book and records the following information:
 - i. Date into service of all new equipment;
 - ii. Dates of exchanges of

- iii. Number of uses to date of wedges, barrels etc.;
- iv. Confirmation that the inspection detailed below has been carried out.

- Ensure taking the following actions:
 - i. Inspect and clean all wedges after each use, and record the fact in the book provided;
 - ii. Clean the teeth of the wedges with a wire brush in order to remove any dirt or rust accumulated in the valleys of the teeth;
 - iii. Replace worn segments as necessary;
 - iv. Coat the backs of the wedges with graphite or wax, according to the grip manufacturer's instructions.
- Return all barrels to the stores for cleaning and checking along with the wedges. As a matter of necessity when returning barrels, see that the insides of the barrels are clean and that the wedges are free to move inside the taper;
- Inspect weekly for the following:
 - i. Distorted anchor-plates;
 - ii. Distortion of stressing equipment, crossheads, etc.;
 - iii. Any cracked welding of the equipment.

8 REFERENCES

- 1) AS 3600 – *Concrete structures*
- 2) AS 5100.5 – *Australia Bridge design, Part 5: Concrete*
- 3) AS/NZS 4671 – *Steel for reinforcement of concrete*
- 4) AS 4672.1/NZS – *Steel prestressing materials, Part 1: General requirements*
- 5) ACI 544.3R – *Guide for specifying, proportioning and production of fiber – reinforced concrete* (2008)
- 6) VicRoads Test Method RC 377.01 – *Determination of the Fibre Content of Fresh Concrete (Wash-out Method)*
- 7) AS/NZS 1554.3 – *Structural steel welding, Part 3: Welding of reinforcing steel*
- 8) AS 1012.8.3 – *Methods of testing concrete – Methods of making and curing concrete – Mortar and grout specimens*
- 9) AS 1012.9 – *Methods of testing concrete – Compressive strength tests – Concrete, mortar and grout specimens*
- 10) ASTM C939 – *Standard Test Method for Flow of Grout for Preplaced-Aggregate Concrete (Flow Cone Method)*
- 11) ASTM C1741 – *Standard Test Method for Bleed Stability of Post-Tensioning Tendon Grout*
- 12) AS 1481 – *Prestressed Concrete Code* (superseded), Standards Australia (1987)
- 13) AS/NZS 2425 – *Bar chairs in reinforced concrete, Product requirements and test methods*

The main aim in handling and placing concrete is to distribute it from the point of delivery on a construction site to its final location as smoothly and efficiently as site conditions will allow – while at the same time maintaining it in a condition where it is both workable and free from segregation. This section describes methods, plant and equipment which may be used to handle and place concrete in a variety of circumstances.

CONTENTS

1. INTRODUCTION	2
2. PRELIMINARY CONSIDERATIONS.....	2
2.1 WORKABILITY.....	2
2.2 SEGREGATION.....	3
3. PLANNING.....	3
3.1 SITE ACCESS	3
3.2 DELIVERY RATE.....	4
4. DISTRIBUTION METHODS.....	5
4.1 GENERAL.....	5
4.2 CHUTES	5
4.3 BARROWS	5
4.4 CRANE AND BUCKET.....	6
4.5 TREMIE CONCRETE.....	6
4.6 PUMPS AND PIPELINES.....	7
5. PLACING	10
5.1 GENERAL.....	10
5.2 AVOIDING SEGREGATION.....	10
5.3 AIDING COMPACTION.....	10
6. SUMMARY	14
7. RELEVANT AUSTRALIAN STANDARDS.....	14

1. INTRODUCTION

Concrete is most commonly delivered to construction sites in a transit-mixer. Even on those projects where the concrete is batched and mixed on site in a dedicated plant (e.g. large highway projects), it will often be most convenient to move the concrete from the mixing plant to the point of placement in these vehicles. They have several advantages, including (a) they can transport workable concrete over quite long distances, and (b) they permit some adjustment to be made to the

workability of concrete, immediately prior to discharge, by the addition of controlled amounts of water while still allowing some remixing of the concrete. AS 1379 ‘*Specification and supply of concrete*’ sets out the conditions under which this may be done.

The handling of concrete on site effectively commences when the concrete is discharged from the truck (or from any other device used to transport it from the batching or mixing plant). The aim in handling concrete will always be to move it to the point of final placement as quickly and as efficiently as the site conditions allow without significantly affecting the plastic properties of the concrete.

A variety of methods, plant and equipment are available for this purpose. In choosing a distribution method, it should be the most appropriate method for use on that site. Care should then be taken to plan concrete handling on the site so that, once concreting operations commence, they proceed smoothly and without delay. Special care should be taken to ensure that the capacity of handling equipment is sufficient to (a) maintain placing operations at their planned rate and (b) match supply capability.

2. PRELIMINARY CONSIDERATIONS

2.1 WORKABILITY

The required concrete workability will normally be determined by the nature of the building element or project in which it is to be placed. For example, concrete to be placed in thin or narrow forms needs to be quite workable if it is to be placed and compacted satisfactorily. On the other hand, concrete to be placed in massive sections may have quite low workability. Consequently, the method chosen to distribute the concrete from the point of delivery to the point of placement in these two

situations may be quite different in terms of delivery capacity and delivery process.

The equipment chosen must be able to maintain the concrete in the required workability condition. High temperatures and high winds can cause concrete to lose workability while being transported to, and moved around, the site – high temperatures by accelerating the rate at which the concrete stiffens and high winds by causing it to lose moisture and dry out. It is generally necessary for processes used to handle concrete on site to keep the concrete ‘cool’ and to prevent it from drying out. (For further information on this aspect see Section 18 ‘Hot- and Cold-Weather Concreting’.)

Corrective measures for losses of workability in excess of those anticipated depend on why such losses occurred. With a slight workability reduction, remixing may be enough to restore workability. In high temperature environments or in cases of long transport distances, the use of retarders may be appropriate. Similarly, slump retention admixtures may need to be considered in the basic mix design. The use of water addition on site to restore slump is problematic, particularly if it is uncontrolled. While this is the simplest approach, and the one often favoured by pump operators and/or placers, it can have significant impacts on concrete strength and durability and may lead to issues with excessive drying shrinkage – not to mention potentially exceeding maximum W/C ratios that may have been specified.

(NOTE: Coloured concretes, where coloured oxides have been used, are particularly sensitive to slump loss. Extra water additions in these cases not only affect general concrete performance, but also affect colour consistency.)

2.2 SEGREGATION

Segregation in concrete is the separation of the coarse aggregate from the mortar. This typically results in the hardened concrete being non-uniform and with weak/porous or honeycombed areas, and an increased likelihood that strength and durability requirements will not be achieved.

To avoid segregation during transport, the concrete should be cohesive and thoroughly mixed. As far as practicable, jolting and vibration of the concrete while distributing it around the site should be minimised and the concrete should be discharged vertically and in a controlled manner into its final position in the forms, or into the distributing equipment.

With flowing (Super Workable) concretes becoming more common, this creates an even greater risk of segregation. Attention to appropriate concrete mix design and good control of admixture use will lower the risk of segregation with these high-workability mixes.

3 PLANNING

3.1 SITE ACCESS

Access to the site by trucks delivering the concrete, either to the distribution equipment or to the point of placement, is an important factor in avoiding delays and interruptions to placing activities.

In planning access to the site, important considerations are:

- Ground conditions, e.g. Its ability to support loaded trucks;
- Headroom and ground clearances – particularly around power lines;
- Availability of adequate turning circles;
- Access to discharge chutes by distribution equipment;
- Holding area for trucks awaiting discharge;
- Suitable site ingress and egress.

Typical dimensions of typical concrete trucks are shown in **Figure 12.1**.

A prime consideration in planning access to the site is to avoid the delays caused by delivery trucks having to manoeuvre whilst on site, particularly when a continuous flow of concrete is required.

TYPICAL SIX-CUBIC-METRE-CAPACITY CONCRETE TRUCK

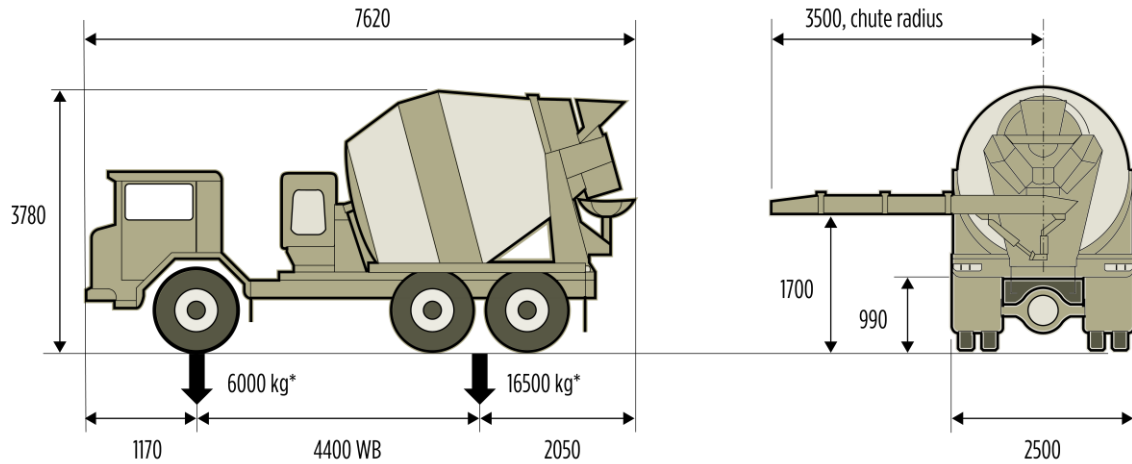

*Axle loads with 6 m³ concrete at 2320 kg/m³

TYPICAL EIGHT-CUBIC-METRE-CAPACITY CONCRETE TRUCK

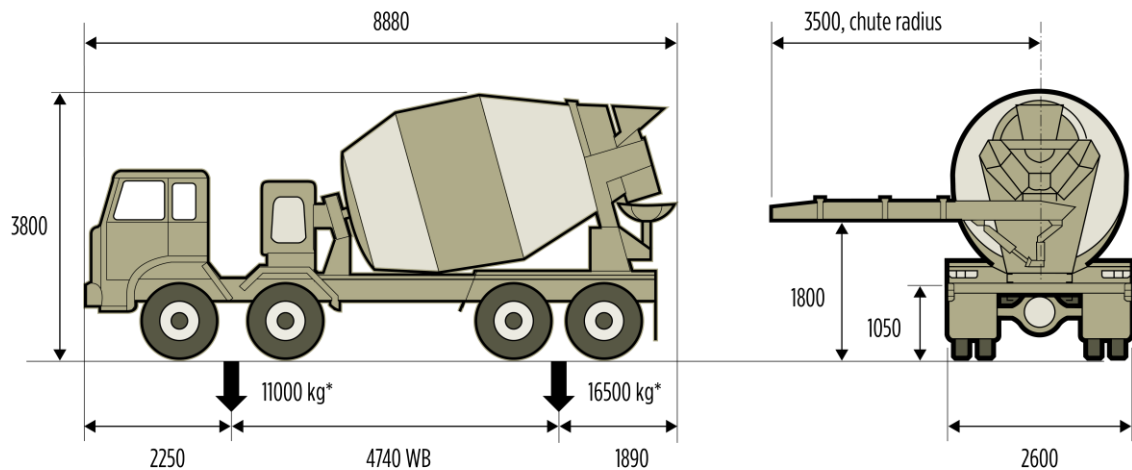

*Axle loads with 8 m³ concrete at 2320 kg/m³

Figure 12.1 – Typical 6-m³ and 8-m³ Transit Mixers (all dimensions are in millimetres)

3.2 DELIVERY RATE

The delivery rate which can be achieved on a site is determined, in part, by the access to the site, i.e. the rate at which the delivery trucks can move on and off the site (**Figure 12.2**). More often, however, it is determined by the rate at which the concrete can be placed. The ideal rate will be where the work proceeds smoothly and the formation of unplanned construction joints (including cold joints) does not occur. Too high a rate is also problematic.

The rate should not be so high that concrete cannot be adequately compacted and/or finished, e.g. in thin walls and columns.

One of the primary concerns involved in organising the delivery of concrete to a project site is safety. Truck movements increase the risks of safety incidents. To reduce these risks, certain measures need to be taken, including (1) designated zones for vehicle movement, (2) use of spotters when trucks are reversing onto (say) a concrete pump, (3) ensuring a minimum 600 mm spacing is observed between trucks

delivering concrete at a pump, and (4) safe areas for testers to operate in when sampling loads of concrete.



Figure 12.2 – Access to the Site (and particularly the ease with which delivery vehicles can move on and off it) has a Significant Influence on the Overall Concrete Supply Rate^{12.1}

where the free-fall of the concrete exceeds two metres, additional controls should be provided (Figure 12.4).



Figure 12.3 – Delivery from a Transit mixer Chute is the Quickest, Most Convenient and Economical Method of Distribution

4 DISTRIBUTION METHODS

4.1 GENERAL

The methods for distributing concrete on site range from simple (e.g. barrows) to sophisticated (e.g. pumps). Whatever the method chosen, it should be capable of moving the concrete uniformly, without delay, and at a rate appropriate to the method of placing.

4.2 CHUTES

On most sites, the transit-mixer chute is the initial means of delivering concrete on site – either to another method of distribution or direct into its final position (Figure 12.3). ‘Off the chute’ delivery is ideal for elements such as strip footings, house floor slabs, road pavements and low retaining walls, provided:

- Truck access to within chute radius is available;
- The element is below truck tray level;
- Free-fall of concrete does not exceed two metres in height.

Chutes can also be a useful means of distributing concrete from a higher to a lower level. In such applications, care must be taken that the chute has sufficient slope for the concrete to flow freely. A minimum slope between 1:2 and 1:1 is often suggested. With long chutes, those which slope steeply, or

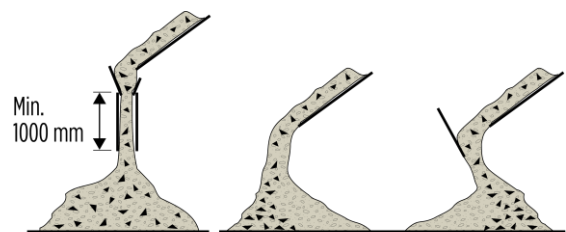

CORRECT

Discharge concrete through a drop chute

INCORRECT

Lack of end control causes segregation, a baffle merely changes the direction of the segregation

Figure 12.4 – Discharging from Long Chutes (i.e. – longer than standard transit mixer chutes)

4.3 BARROWS

Barrows and small handcarts/buggies are an appropriate means of moving concrete on small sites or where only small quantities of concrete have to be placed (Figures 12.5 and 12.6). These methods are labour intensive and have largely been replaced by more-efficient methods. Other limitations are that:

- Only a low placing rate of about 1-1.5 m³/h can be achieved;
- The travel distance is limited to about 50 m for continuous work.

When used, care should be taken to provide near level, smooth runways and access ways to avoid jolting which may promote segregation of the concrete.



Figure 12.5 – Barrows, despite their limitations, are the Most Suitable Distribution Means on Small Projects^{12.2}



Figure 12.6- Small Handcarts and Buddies (of about 100-litre capacity) have been largely superseded by more Efficient Methods

4.4 CRANE AND BUCKET

The use of a crane and bucket or skip or 'kibble' are appropriate means of handling concrete on sites where adequate crane time is available, other access is limited and/or a concrete mix which is difficult to pump is required. Buckets or skips of 1-2 m³ capacity are most commonly used (**Figure 12.7**). There are 'lay-down' varieties that may be filled readily from a truck-mixer. Normally, they have hand-operated discharge gates which permit sufficient control of location and discharge (**Figure 12.8**).

On large mass concrete projects, buckets of up to 6 m³ capacity may be employed with the discharge gates operated by compressed air. In discharging buckets and skips, care must be taken that formwork and reinforcement are not damaged by the impact of the concrete. High impact forces and an increased risk of segregation are possible consequences if the

concrete is discharged from a height of more than about two metres.



Figure 12.7 – Crane Buckets and 'Kibbles' are easily filled from Transit Mixers^{12.3}

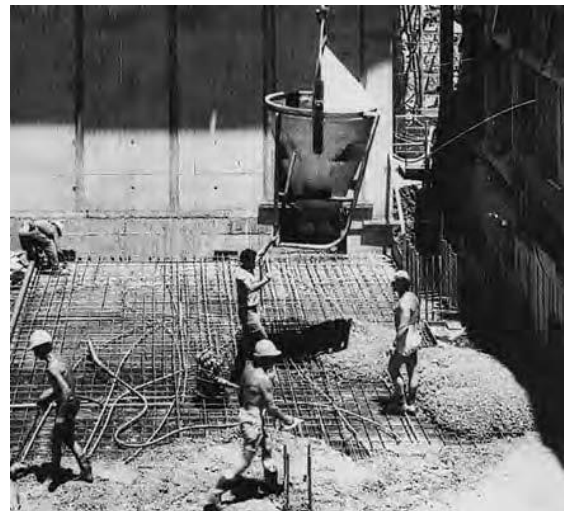

Figure 12.8 – Hand-operated Gates on Crane Buckets give control over Concrete Discharge

The placing rate is dependent on the bucket capacity and the height and distance from the pick-up point. For example, about 13 m³/h could be placed on a tenth-floor level using a 1 m³ bucket, while about 20 m³/h could be placed using a 2 m³ bucket. On a fifth-floor level, the placing rates would only be about 10% higher.

4.5 TREMIE CONCRETE

Tremie concrete refers to the delivery of suitable concrete from a hopper and through a long pipe – most often used for placing concrete underwater or at depth in concrete piles. The concrete is initially unloaded into an above-ground hopper and from there it flows

through the vertical pipe down to the required depth. As concrete flows from the bottom of the pipe, more concrete is added to the hopper so that a continuous feed is established. As the concrete flows from the bottom of the tremie the pipe is gradually lifted while ensuring that the end of the tremie tube remains within the body of the concrete being placed, usually to a depth of about 1 metre. The concrete around the end of the tremie effectively seals the pipe and, in the case of placing concrete under water, prevents the water washing paste from the concrete being delivered. It is necessary for the concrete to have appropriate flow capability for this method to work properly (**Figure 12.9**). Further discussion on tremie concrete is provided in Part VI, Section 21 of this Guide.



Figure 12.9 – Tremie Pipe being filled from Above-ground Hopper^{12.4}

4.6 PUMPS AND PIPELINES

General – Concrete pumps and pipelines are perhaps the most widely used of all methods of distributing concrete on construction sites (**Figure 12.10**) in Australia today. The ready availability of mobile pumps, and their relative reliability, make them an efficient and economical means of transporting concrete, even on quite small sites.

A wide range of pump types are available, generally trailer- or truck-mounted, although fixed installations are not uncommon where the pump has to be in frequent operation (**Figure 12.11**) or where it is used over longer periods of time.



Figure 12.10 – Concrete Distribution by Pump (from a discharge point in street where permitted) is the Most Common Method



Figure 12.11 – Fixed Pumps generally have the Highest Pumping Capacity and are the usual Choice for Major Projects^{12.5}

Usually, however, concrete pumps are mobile and are often fitted with an articulated boom which enables the unit to deliver concrete over a radius of 30 m or more (**Figure 12.12**). Such units require little set-up and are especially versatile in the range of applications they can handle. They may also be coupled to fixed pipelines for delivering concrete over greater distances, say 60 m vertically and up to 300 m

horizontally. For greater distances, more powerful pumps are required.



Figure 12.12 – Mobile Concrete Pumps are quick to Set up and Versatile in their Range of Applications^{12.6}

In tall city buildings, concrete has been pumped to heights of 200 m or more and on large flat sites, for horizontal distances of up to 1,000 m. Such installations require quite rigidly fixed pipelines to withstand the considerable pressures involved. In these situations, 'piston pumps' are generally the pump of choice.

While the main focus on concrete pump capability is on high delivery rates, there are situations where reliable delivery at low rates is required, e.g. for delivering block fill. In these situations, a 'squeeze' or 'peristaltic' pump type, which can deliver reliably at rates as low as 1 m³/hr, can be used.

The advantages of using pumps include:

- High output;
- Versatility and flexibility (they can distribute concrete both vertically and horizontally and require little space);
- Continuous distribution;
- Short set-up time;
- Low labour requirement.

It should, however, be noted that:

- Concrete mix designs need to be appropriate, particularly for tall buildings or for long transfer distances;

- Some pump mixes may give increased concrete drying shrinkage;
- High slump concrete mixes may have a susceptibility to segregate when pumping;
- Downhill pumping is difficult and will require a more cohesive concrete mix design to prevent segregation.

Pump Selection – The rate of delivery which can be achieved will depend on the type of pump and its power; the distances to be pumped horizontally and vertically; the number of bends; and the type of concrete mix. Smaller pumps may deliver up to 10 m³/h and high-performance units deliver up to 80 m³/h. However, this rate can be compromised in practice because of the need to move and reposition pipelines.

The selection of a suitable pump will depend on the maximum required output and pumping pressure. The output required is a function of the placing rate and the actual time the pump will be operating. Thus, if an overall placing rate of 30 m³/h is required but the pump will be in use for only 45 minutes in each hour, the required output will be $(30 \times 60/45) = 40$ m³/h.

The required pumping pressure will depend on the:

- Required output as determined above;
- Pipeline diameter (often controlled by the maximum aggregate size);
- Total equivalent length of the pipeline (actual horizontal length plus an equivalent horizontal length for vertical pipe distances, bends and any reducer piping or hydraulic placing boom that may be used);
- Plastic properties of the concrete (often expressed as its slump).

From this information the required pumping pressure can be determined from a nomograph such as that shown in (Figure 12.13).

USE OF CHART

From Pump Delivery Output move RIGHT to Pipeline Diameter, move DOWN to Total Equivalent Length* of Pipeline, move LEFT to Slump and UP to Pipeline Pressure.

* Total equivalent length of pipeline is the horizontal length, plus an equivalent length for each metre of vertical pipe, for each 90° bend, for each 45° bend, for any reducer pipe and for a hydraulic placing boom if used.

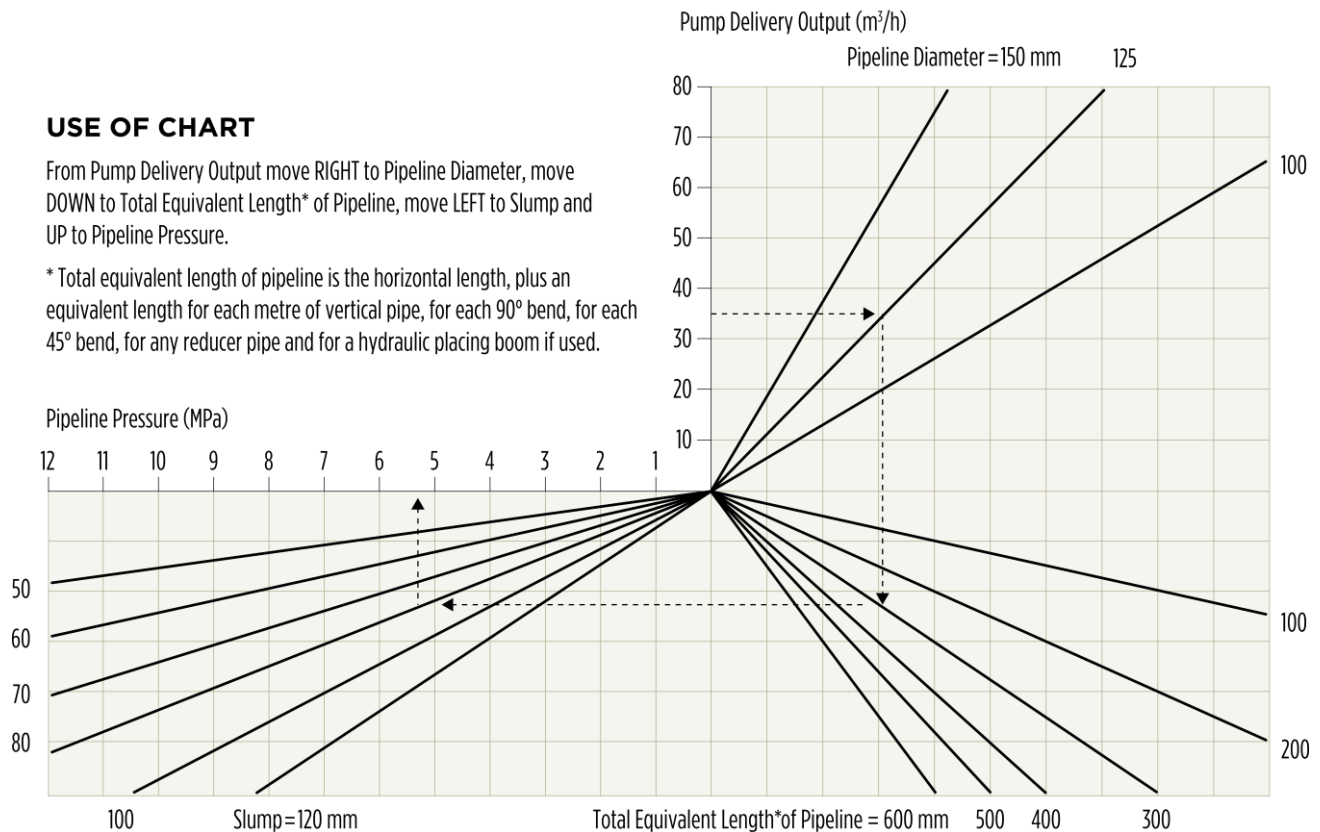

Figure 12.13 – Nomograph for Determining the Required Pumping Pressure

The pumping power required can be calculated from the equation:

$$\text{Power (kW)} = \text{Output (m}^3/\text{h)} \times \text{Pressure (MPa)} / 2.5 \dots \text{Eq.12.1}$$

The design of a successful pumping operation requires an experienced operator. Of paramount importance is preplanning and, in particular, close liaison between the placing contractor, the pump operator and the concrete supplier.

Pumping Operations – Before pumping commences, the pump and pipelines must be lubricated by coating the internal surfaces with a cement-based slurry, pumped through the pipes at the rate of about 2.5 litres of slurry per metre of pipeline. After pumping is completed, the pipelines must be cleaned out as soon as possible as any paste residue will lead to increased pipe friction and may eventually cause blockages.

Pipelines should be adequately supported and fixed in position since quite substantial forces (thrusts) can be generated as the concrete is forced through the lines. Joints should be watertight as loss of paste from the mix can lead to blockages. The wall thickness of the pipe should be adequate for the pressures that will be experienced. Pipelines should also be readily accessible for maintenance and cleaning should a blockage occur.

Once commenced, concrete pumping should be continuous to avoid blockages in the pipeline. If concrete is to be discharged directly into the forms or on-grade in flatwork, sufficient manpower and equipment to compact and finish the concrete must be available. It is very important that the rate of pumping matches the rate of placing and finishing.

While 'pumpable' concrete mixes are now readily available, it is still required that the concrete supplier be notified 'of the intended

method of placement' (see Clause 1.5.3.2(d) of AS 1379). Not all concrete mixes can be pumped successfully. For example, mixes required to have very low shrinkage characteristics may be difficult to pump because of limitations on the fines content of the mix. Similarly, 'pumpable' mixes may not be the best suited to very high standards of off-form finish. Low slump concretes are generally not easily pumpable.

5. PLACING

5.1 GENERAL

As is the case when handling concrete, certain fundamental considerations govern placing techniques. First and perhaps foremost is the need to avoid segregation (separation of the paste and aggregate materials) of the concrete caused by using improper techniques. Second is the need to ensure thorough compaction of the concrete. Whilst compaction requirements are discussed in more detail in Section 13 'Compaction', the manner in which concrete is placed can have a significant influence on its ability to compact under vibration.

5.2 AVOIDING SEGREGATION

The most important rules for avoiding segregation during the placing of concrete, in any element, are:

- Concrete should be placed vertically and from as near as possible to its final position;
- Concrete should not be made to flow into position. Where concrete must be moved it should be shovelled into position.

Other techniques for avoiding segregation during placing depend on the type of element being constructed and on the type of distribution equipment being used.

For flatwork and slabs incorporating ribs and beams (i.e. shallow forms) the techniques shown in (Figure 12.14) should be adopted. For walls and columns (i.e. deep, narrow forms), problems occur when the concrete is dropped from too great a height and ricochets

off the reinforcement and form-faces, resulting in segregation. The means of avoiding this risk vary with the type of distribution equipment being used (Figure 12.15).

5.3 AIDING COMPACTION

To aid proper compaction of the concrete, care should be taken to place concrete in layers which are of a suitable depth for the compaction equipment being used. Layers that are too deep make it virtually impossible to adequately compact the concrete to full depth, with the risk of leaving entrapped air that creates voids and prevents the concrete from achieving its potential or required strength and durability performance.

The two main types of compaction equipment are (1) immersion (poker) vibrators (Figures 12.16 and 12.17), and (2) vibrating-beam screeds (Figure 12.18). The effective radius of action of an immersion vibrator depends on its operating frequency and amplitude as well as the diameter of the vibrator shaft. The common sizes found in normal concrete construction work have a radius of action between 200 mm and 350 mm. This means, in practice, concrete should be placed in uniform layers ranging from 250 mm to 400 mm, depending on the vibrator being used. To ensure each layer is properly merged together, the vibrator should penetrate about 150 mm into the lower layer of previously compacted concrete (Figure 12.19).

The effective depth of compaction of vibrating-beam screeds depends on the beam weight, its amplitude, its frequency and the forward speed. For the commonly available range of surface vibrators, the maximum effective depth is 200 mm.

(NOTE: For slabs between 150 mm and 200 mm thick, immersion vibrators should be used adjacent to all construction joints and edges to supplement the vibrating screed in these areas.) For slabs greater than 200 mm thick, immersion vibrators should be employed to compact the concrete and the vibrating-beam screed used to finish it (Figure 12.19).)

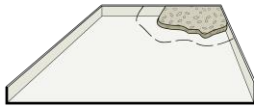

CORRECT
Commence placing at one corner of the formwork

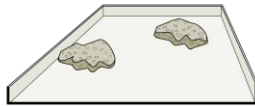

INCORRECT
Random placing can result in segregation and makes it more difficult to achieve correct levels

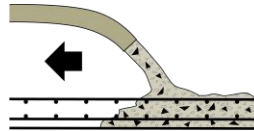

CORRECT
Regardless of the distribution method, always deposit concrete into the face of that already placed

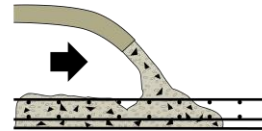

INCORRECT
Depositing concrete away from the face of that already placed can cause poor intermixing and segregation

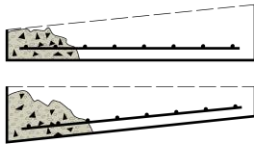

CORRECT
If either the final surface or the soffit is sloping, commence placing at the lowest point

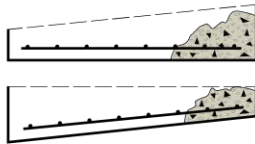

INCORRECT
Placing commenced from the highest point makes it more difficult to achieve correct levels and can lead to segregation as the concrete tends to settle down the slope

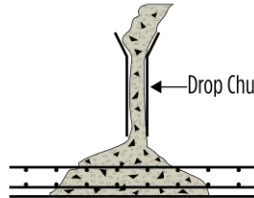

CORRECT
Use a drop chute if concrete has to fall more than two metres

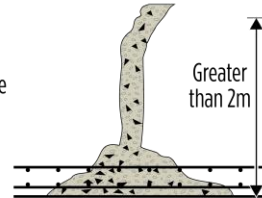

INCORRECT
Allowing concrete to free-fall more than two metres can displace reinforcement, damage formwork and cause concrete to segregate

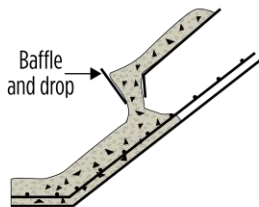

CORRECT
If placing on a surface with a chute, always use a baffle and drop at the end of chute

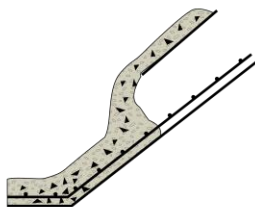

INCORRECT
The velocity from a free-end chute tends to carry the concrete down the slope, separating the aggregate, which goes to the bottom of the slope

Figure 12.14 – Placing Techniques for Flatwork

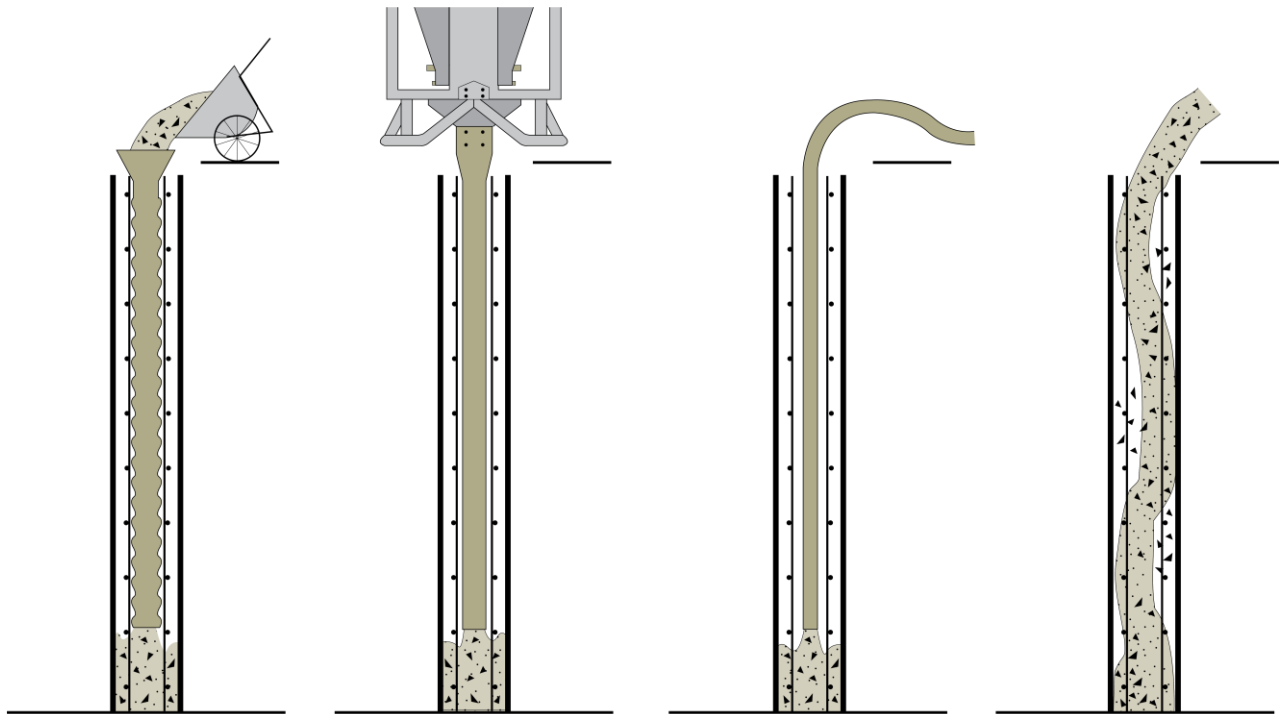

CORRECT
When placing from chutes and barrows, discharge concrete into a hopper leading to a light, flexible drop chute

CORRECT
When placing with crane and bucket, use a flexible drop chute connected to a collector cone which is permanently attached to the bucket frame

CORRECT
When placing with a concrete pump, extend the hose to the bottom of the form and withdraw as the form is filled

INCORRECT
Long uncontrolled drops cause segregation as the concrete strikes against the forms and aggregates ricochet off reinforcement. Mortar is also left on the form faces and reinforcement

Figure 12.15 – Placing Techniques for Walls and Columns

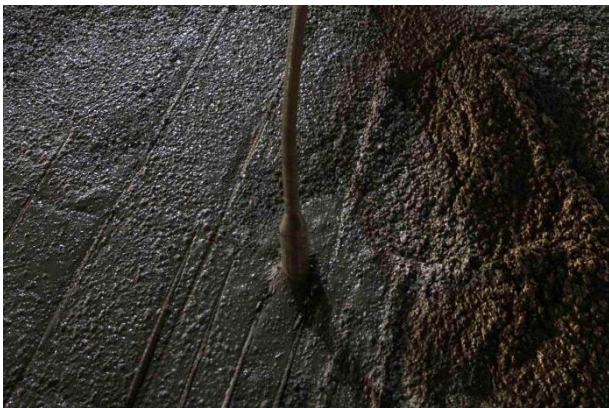

Figure 12.16 – Action of Immersion Vibrator^{12.7}



Figure 12.17 – Immersion Vibrator in Use on Slab^{12.8}



Figure 12.18 – Vibrating Screed in Use^{12.9}

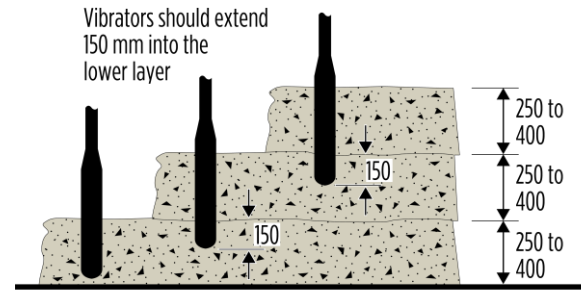

Concrete to be placed in uniform layers and of a thickness to match the 'power' of the vibrator (usually between 250 and 400 mm)

COMPACTION BY IMMERSION VIBRATORS

NOTE: Maximum depth for compaction by a vibrating screed alone is 200 mm

D = 150 to 200 mm
Use immersion vibrators as supplement along construction joints and edges
D > 200 mm
Use immersion vibrators to compact the concrete and a vibrating screed to finish

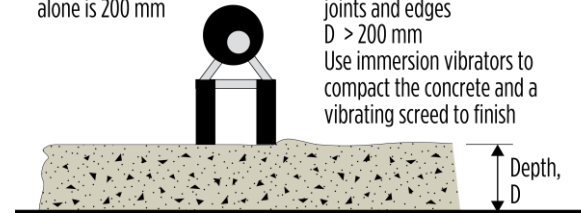

Concrete usually placed in a single layer, slightly overfilling the forms such that a bead of concrete is maintained ahead of the screed

COMPACTION BY VIBRATING-BEAM SCREEDS

Figure 12.19 – The Depth of the Layers in which Concrete is placed Dictates the Requirements and Methods necessary to achieve Effective Compaction

6. SUMMARY

Method	Application	Comment
Chute	Where work is below the level of truck tray; Ideal for strip footings, house floor slabs, road pavements, low retaining walls, etc.	May be direct from transit mixer if work is within radius of its chute; Free fall of concrete should not exceed 2 m without additional end controls.
Barrows and hand carts	Suitable for small projects such as domestic construction.	Labour intensive; Low placing rate (typically 1-1.5 m ³ /h); Maximum distance about 50 m for continuous work; Requires relatively level, smooth access.
Crane and bucket	Suitable for mass concrete structures and heavyweight concretes; Can be used when concrete is unsuitable for pumping.	Adequate crane time must be available; Limitations dependent on bucket size, crane capacity and reach.
Tremie	For placement of concrete under water or in deep piles.	The concrete needs to readily flow from the delivery hopper down the tremie pipe; The tremie pipe should remain about 1 metre below the surface of the concrete being placed to prevent paste being washed out of the mix.
Pumps and pipelines	Versatile and flexible – can distribute concrete both vertically and horizontally.	Require little space; High output; Continuous distribution; Short set-up time; Low labour requirement; Not suitable for all concretes; Possibility of increased concrete shrinkage; Downhill pumping is difficult.

7. RELEVANT AUSTRALIAN STANDARDS

- 1) AS 1379 – *The specification and supply of concrete*
- 2) AS 3600 – *Concrete structures*

End Notes:

12.1 Photo adopted from 'Construction Site, Construction', licensed under Creative Commons Zero - CC0, <https://www.pikrepo.com/fazbg/construction-site-construction>

12.2 Photo adopted from the United States Marine Corps, Public Domain license, https://commons.wikimedia.org/wiki/File:Defense.gov_photo_essay_120125-M-PY060-002.jpg

12.3 Photo adopted from 'Cement truck, and bucket, at the excavation SE of Victoria and Richmond, 2017 08 18 -c', by booledozer, licensed under the Creative Commons CC0 1.0 Universal Public Domain Dedication, [https://commons.wikimedia.org/wiki/File:Cement_truck_and_bucket_at_the_excavation_SE_of_Victoria_and_Richmond_2017_08_18_-_c_\(35893422913\).jpg](https://commons.wikimedia.org/wiki/File:Cement_truck_and_bucket_at_the_excavation_SE_of_Victoria_and_Richmond_2017_08_18_-_c_(35893422913).jpg)

12.4 Photo adopted from '*Tremie concrete placement at Olmsted*' by LouisvilleUSACE, licensed under Attribution 2.0 Generic (CC BY 2.0),

<https://www.flickr.com/photos/louisvilleusace/28947270312>

12.5 Photo adopted from '*Liebherr Stationary concrete pump THS 70 D-K. In the background: Liebherr Piling and drilling rig LRB 355 in Dornbirn (Vorarlberg, Austria)*', by Asumnipal, licensed under the Creative Commons Attribution-Share Alike 4.0 International license,

https://commons.wikimedia.org/wiki/File:Liebherr_THS_70_D-K_Raupenbetonpumpe_-_01.jpg

12.6 Photo adopted from Radomil, licensed under the Creative Commons Attribution-Share Alike 3.0 Unported license,

https://commons.wikimedia.org/wiki/File:Concrete_Pump_RB.JPG

12.7 Photo adopted from '*Worker uses a concrete vibrator to ensure the correct consistency in the concrete*', by USC Capitol, public domain license,

[https://commons.wikimedia.org/wiki/File:Canon_Renewal_Project_-_August_2015_\(21094338346\).jpg](https://commons.wikimedia.org/wiki/File:Canon_Renewal_Project_-_August_2015_(21094338346).jpg)

12.8 Photo adopted from '*Vilas Road Concrete Pour April 19, 2018*', by Oregon Department of Transportation, licensed under Attribution 2.0 Generic (CC BY 2.0),

<https://www.flickr.com/photos/oregondot/39760340800/in/photostream/>

12.9 Photo adopted from '*Wacker Neuson Vibrationsbohle P 35A*', by Baumeister 99, licensed under the Creative Commons Attribution-Share Alike 3.0 Unported license,

https://commons.wikimedia.org/wiki/File:Vibrationsbohle_web.jpg

In this section, the techniques used to compact or consolidate plastic concrete with the aim of achieving its optimum density are described. Generally, compaction and finishing (see Section 14 *'Finishing Concrete Flatwork'*) are two separate operations. However, on flat horizontal surfaces (i.e. flatwork), they are often parts of the same operation and can be considered together.

CONTENTS

1. INTRODUCTION	2
2. PURPOSE.....	2
3. THE PROCESS.....	3
4. EFFECT ON PLASTIC CONCRETE.....	3
5. EFFECT ON HARDENED CONCRETE .	4
6. METHODS AND EQUIPMENT	4
6.1 GENERAL.....	4
6.2 IMMERSION VIBRATORS.....	4
6.3 SURFACE VIBRATORS	7
6.4 FORM VIBRATORS.....	9
7. UNDER-VIBRATION AND OVER-VIBRATION.....	9
8. REVIBRATION.....	10
9. SUMMARY: SURFACE DEFECTS FROM CONCRETE PLACEMENT AND COMPACTION.....	11
10. RELEVANT AUSTRALIAN STANDARDS.....	12

1. INTRODUCTION

Compaction is one of several important site operations that, in combination, enable the concrete to reach its potential design strength, density and durability. Properly carried out, it ensures that concrete fully surrounds, engages with and protects the reinforcement, tendons and cast-in inserts. It also has a direct impact on achieving the specified surface finish.

While the compacting and finishing of concrete are generally two separate operations, sometimes, particularly with flat horizontal surfaces, they become parts of the one operation. In such circumstances, it should be noted that a smooth surface finish is not necessarily evidence of good compaction

underneath it. Care should always be taken to ensure that concrete is adequately compacted.

In-depth discussions of the critical issues are contained in the following documents:

- ACI Committee 309, *'Guide for Consolidation of Concrete Report 309R-96'*, ACI Manual of Concrete Practice, Part 2, Chicago (2000);
- ACI Committee 309, *'Behaviour of Fresh Concrete During Consolidation Report 309.1R - 99'*, ACI Manual of Concrete Practice, Part 2, Chicago (2000);
- ACI Committee 309, *'Consolidation-Related Surface Defects Report 309.2R - 98'*, ACI Manual of Concrete Practice, Part 2, Chicago (2000);
- ACI Committee 309, *'Guide to Consolidation of Concrete in Congested Areas Report 309.3R - 92'*, ACI Manual of Concrete Practice, Part 2, Chicago (2000).

2. PURPOSE

Compaction is the process that expels entrapped air from freshly placed concrete and consolidates the aggregate and paste components with a resultant increase in the density of the concrete. It significantly increases the ultimate strength of concrete and enhances the bond with reinforcement. It also results in (a) increases in the abrasion resistance and general durability of the concrete, (b) a decrease in its permeability and (c) helps to minimise shrinkage and creep characteristics.

Proper compaction also ensures that (a) the reinforcement, tendons, inserts and fixings are completely encased in dense concrete; (b) the formwork is completely filled (i.e. there are no pockets of honey-combed concrete); and (c) that the required surface finish is obtained on vertical surfaces.

AS 3600 specifies that concrete shall be compacted during placing so that:

- A monolithic mass is created between the ends of the member, planned joints or both;
- The formwork is completely filled to the intended level;
- The entrapped air is expelled;
- All reinforcement, tendons, ducts, anchorages and embedments are completely surrounded;
- The specified finish to the formed surfaces of the member is provided;
- The required properties of the concrete can be achieved.

3. THE PROCESS

When first placed in the form, normal concretes (i.e. excluding those with very low or very high workability) will contain between 5% and 20% by volume of entrapped air which has been included during the mixing process. The aggregate particles, although coated with mortar, will also tend to arch against one another and are prevented from slumping or consolidating by internal friction.

Compaction of concrete is, therefore, a two-stage process (**Figure 13.1**). First, the aggregate particles are set in motion and the concrete consolidated to fill the form and give a level top surface (by inducing 'liquefaction'). In the second stage, entrapped air is expelled. This description of the process is true whether compaction is carried out by rodding, tamping (and similar manual methods), or when vibration is applied to the concrete. Vibration, by temporarily 'liquefying' a much larger volume of the concrete, is generally much more efficient than tamping or rodding by hand, and hence is almost universally used on construction sites.

It is important to understand that compaction is a two-stage process and to recognise each stage. With vibration, initial consolidation of the concrete (liquefaction) can often be achieved relatively quickly. The concrete liquefies and the surface levels out, giving the impression that the concrete is compacted. Entrapped air takes a longer time to rise to the surface. Compaction should therefore be continued until this is

accomplished, i.e. until air bubbles no longer appear on the surface.

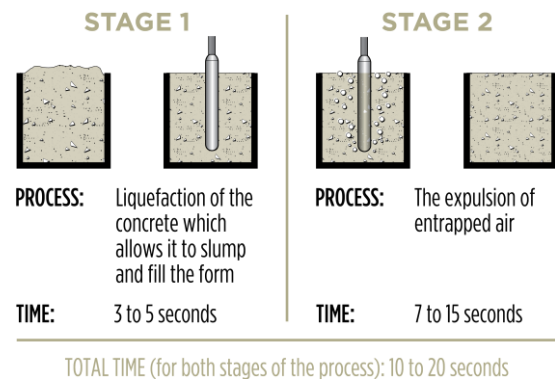

Figure 13.1 – The Process of Compaction

4. EFFECT ON PLASTIC CONCRETE

The effect of vibration on the properties of plastic concrete needs to be understood to ensure that the type and amount of vibration applied to the concrete are appropriate, otherwise defects such as excessive mortar loss and other forms of segregation can be the result.

The concrete mixture as supplied to the project needs to be properly proportioned. Concretes lacking fines can be difficult to compact and, even when fully compacted, can have high porosity. On the other hand, those with too high a fines content, particularly if they also have a high slump, may be prone to segregation and excessive bleeding. Importantly, it should be noted that properly proportioned concretes are difficult to over-vibrate and cautionary notes in specifications regarding over-vibration may result in concrete on the project actually being under-vibrated with resulting loss of potential strength and durability performance.

Concretes with lower workability (i.e. stiffer mixes) will require a greater energy input to compact them fully. This may be achieved by using a high-energy vibrator or by vibrating the concrete for a longer time. In the latter case, the vibrator must have sufficient capacity to liquefy the concrete. Conversely, more workable mixes will require less energy input.

The size and angularity of the coarse aggregate will also affect the effort required to fully compact concrete. The larger the aggregate,

the greater the effort required. Angular aggregates will require greater effort than smooth or rounded aggregates.

5. EFFECT ON HARDENED CONCRETE

Since compaction of concrete is designed to expel entrapped air and optimise the density of the concrete, it benefits most of the properties of hardened concrete. As can be seen (**Figure 13.2**), its effect on compressive strength is dramatic. For example, the strength of concrete containing 10% of entrapped air may be reduced by as much as 50% compared to when the concrete is fully compacted.

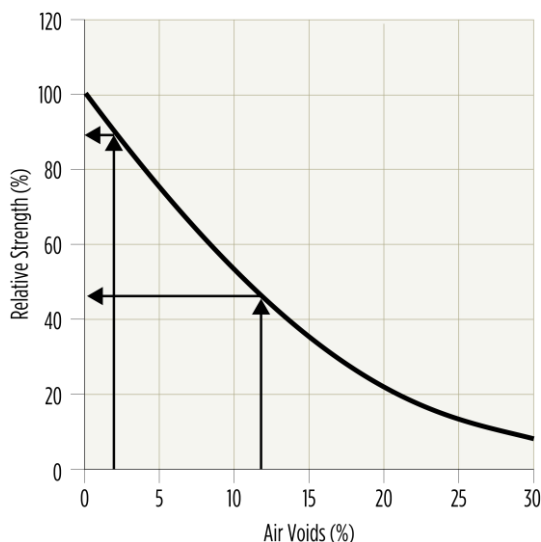

Figure 13.2 – Loss of Strength due to Air Voids from Incomplete Compaction

Permeability is similarly affected since compaction, in addition to expelling entrapped air, promotes a more even distribution of pores within the concrete, resulting in more of them becoming discontinuous. The durability of the concrete is consequently improved except, perhaps, in freeze-thaw conditions, where excessive vibration can expel amounts of intentionally entrained air which is designed to increase the freeze-thaw resistance of hardened concrete (see Section 25 'Properties of Concrete').

The abrasion resistance of concrete surfaces is normally improved by adequate compaction. However excessive vibration, and particularly

excessive working of the surface, can cause a thick layer of mortar (and moisture) to collect (and eventually harden) on the surface, thereby reducing its potential abrasion resistance. In flatwork, a careful balance is therefore required to expel entrapped air without bringing excessive amounts of mortar (fines) to the surface of the concrete.

6. METHODS AND EQUIPMENT

6.1 GENERAL

Two types of vibrators are common on building sites – immersion vibrators and surface vibrators. Each has its appropriate sphere of application, although on floors and other flatwork it is not uncommon for them to be used in combination. A third type – form vibrators – is commonly used in factories for precast work, and sometimes on building sites.

6.2 IMMERSION VIBRATORS

Frequently referred to as 'poker' or 'spud' vibrators, immersion vibrators consist essentially of a tubular housing which contains a rotating eccentric weight. The out-of-balance, rotating weight causes the casing to vibrate and, when the vibrator is immersed in concrete, the vibration force is transferred into concrete itself. Depending on the diameter of the casing, and on the frequency and the amplitude of the vibration, an immersion vibrator may have a radius of action of between 100 mm and 500 mm (**Table 13.1**).

Immersion vibrators may be driven by:

- A flexible shaft connected to a petrol, diesel, or electric motor;
- An electric motor situated within the tubular casing;
- Compressed air.

Flexible-shaft vibrators may have either (a) a conical pendulum, which runs around the inside of the casing like an epicyclic gear, or (b) a straight rotating weight. Type (a) have the advantage that they generally have thinner heads (which is useful in reinforced members). They also have higher amplitudes at the tip than

that obtained further up the casing. This helps compact the concrete at the surface as the vibrator is withdrawn from the concrete.

Electrically powered vibrators, with the motor in the head driving an eccentric weight, are relatively light in weight and, with a switch located on the vibrator, are easy to handle.

Vibrators powered by compressed air normally have the motor driving an eccentric weight

located within the casing. They are most common in the larger diameter tools used for compacting mass concrete (e.g. in dams).

The effectiveness of an immersion vibrator is dependent on its frequency and amplitude, the latter being dependent on the size of the head, the eccentric moment and the head weight – the larger the head, the larger the amplitude.

Table 13.1 – Characteristics and Applications of Internal Vibrators

Head Diameter (mm)	Recommended frequency (Hz) ¹	Average amplitude (mm) ²	Radius of action (mm) ^{3,5}	Rate of concrete placement (m ³ /h per vibrator) ^{4,5}	Application
20-40	150-250	0.4-0.8	80-150	0.8-4	High slump concrete in very thin members and confined places. May be used to supplement larger vibrators where reinforcement or ducts cause congestion in forms.
30-60	140-210	0.5-1.0	130-250	2.3-8	Concrete 100-150 mm slump in thin walls, columns, beams, precast piles, thin slabs, and along construction joints. May be used to supplement larger vibrators in confined areas.
50-90	130-200	0.6-1.3	180-360	4.6-15	Concrete (less than 80 mm slump) in normal construction, e.g. walls, floors, beams and columns in residential, commercial and industrial buildings.
80-150	120-180	0.8-1.5	300-500	1-31	Mass and structural concrete of 0-50 mm slump placed in quantities up to 3 m ³ in relatively open forms of heavy construction.

NOTE: Adapted from Table 5.15, ACI Committee Report 'Consolidation of Concrete', ACI Manual of Concrete Practice, Part 2 (1993).

¹ While vibrator is operating in concrete.

² Computed or measured. This is peak amplitude (half the peak to peak value), operating in air. Reduced by 15-20% when operating in concrete.

³ Distance over which concrete is fully consolidated.

⁴ Assumes insertion spacing 1.5 times the radius of action, and that vibrator operates two-thirds of time concrete is being placed.

⁵ Reflects not only the capability of the vibrator but also differences in workability of the mix, degree of de-aeration desired, and other conditions experienced in construction.

Table 13.1 summarises the characteristics and applications of internal vibrators. As a general rule, the radius of action of a given vibrator not only increases with the workability of the concrete, but also with the diameter of the head. A good general rule is to use as large a diameter head as practicable, bearing in mind

that vibrators with diameters in excess of 100 mm will probably require two workers to handle them. For smaller diameter vibrators the appropriate head size will be dependent on the width of the formwork, the spacing of the reinforcement and the thickness of concrete cover.

The *frequency* of a vibrator is the number of vibrations per second [the unit is Hertz (Hz)]. In general, high-frequency vibrators are most suited to high-slump concrete and small maximum-sized aggregates; while low frequency vibrators are more suited to low slump concrete and large maximum-sized aggregates.

The *amplitude* is the maximum displacement of the head from its point of rest (measured in mm). It will be larger in air than in plastic concrete which has a damping effect. Generally, high-amplitude vibrators are most suited to low-slump/large maximum-sized aggregate concrete; while low amplitude vibrators are most suited to high slump concrete and small maximum-sized aggregates.

Immersion vibrators should be inserted vertically into concrete, as quickly as possible, and then held stationary until air bubbles cease to rise to the surface – usually about 15-20 seconds (**Figure 13.3**). The vibrator should then be slowly withdrawn and reinserted in a fresh position adjacent to the first. These movements should be repeated in a regular pattern until all the concrete has been compacted (**Figure 13.4**). Random insertions are likely to leave some areas of the concrete uncompacted. The vibrator should not be used to ‘help’ concrete to flow horizontally in the forms, as this can lead to segregation.



Figure 13.3 – Using an Immersion Vibrator

In deep sections such as walls, foundations and larger columns, the concrete should be placed in layers (lifts) about 300 mm thick. The vibrator should penetrate about 150 mm into the previous layer of compacted concrete to meld the two layers together to avoid ‘cold-

pour’ lines on the finished surface. In small columns where concreting is continuous, the vibrator may be slowly raised as the concrete is placed. However, care should be taken to ensure that the rate of placement is slow enough to allow the concrete to be fully compacted and the entrapped air to be able to reach the surface. Care should also be taken to avoid trapping air on the form face and a means of lighting the interior of the form while the concrete is being placed and vibrated should be provided.

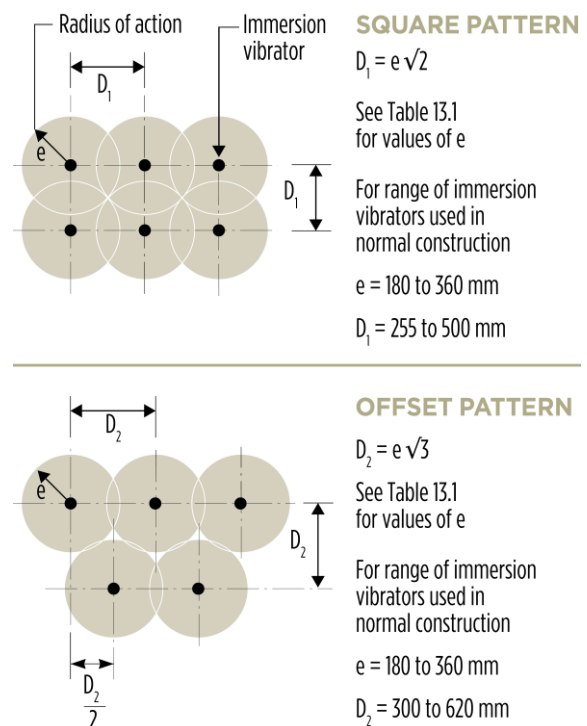

Figure 13.4 – Alternative Patterns for Use of Immersion Vibrators

The vibrator should not be allowed to touch the forms as this can cause ‘burn’ marks that will be reflected on the finished surface. Generally, the vibrator should be kept about 50 mm clear of the form face. Similarly, the vibrator should not be held against reinforcement as this may cause its displacement.

Stop-ends, joints and inclined forms are prone to trapping air. To minimise this tendency, the best technique is to place the concrete close to, but away from, the form and insert the immersion vibrator close to the leading edge of the concrete forcing it to properly fill the corner (**Figure 13.5**).

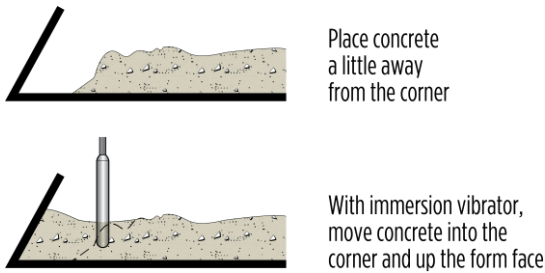

Figure 13.5 – Compaction at Stop Ends and Inclined Forms

Void-formers are prone to trapping air on their undersides if concrete is placed from both sides and then compacted. Concrete should be placed at one side and, while maintaining a head, vibrated until it appears at the other side. (Note that the void-former needs to be fixed so it can resist the pressure of the concrete – from both sideways and vertical directions) Once the top surface of the concrete is fully visible from above, then placing can continue normally (Figure 13.6). This technique should be used in other similar situations, such as encasing steel beams.

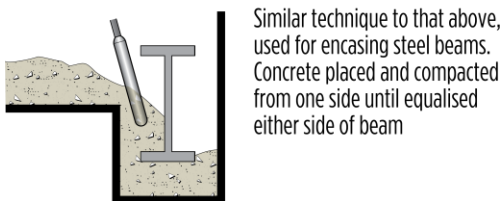
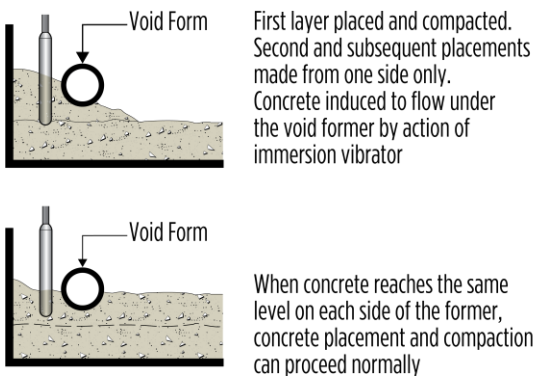

Figure 13.6 – Compacting around Void Formers and Encased Beams

6.3 SURFACE VIBRATORS

Surface vibrators are applied to the top surface of concrete and act downwards. They are very useful for compacting slabs, industrial floors, road pavements, and similar flat surfaces.

They also aid in levelling and finishing the surface.

Several types of surface vibrators are available. Some of these (e.g. vibrating-roller screeds and pan-type vibrators) are used mainly on specialised equipment such as road paving plant – but the most common type is the single or double vibrating-beam screed.

A vibrating-beam screed consists of either one or two beams, made from aluminium, steel or timber, to which is attached some form of vibrating unit. This may be a single unit, mounted centrally, or may consist of a series of eccentric weights on a shaft supported by a trussed frame and driven by a motor at one end. In general, the centrally mounted units have a maximum span of about 6 m, but the trussed units may span up to 20 m. The small units are normally pulled forward manually (Figure 13.7), whereas the larger units may be winched, towed or be self-propelled.



Figure 13.7 – Typical Vibrating Screed Surface Vibrator

The intensity of vibration and, hence, the amount of compaction achieved, decreases with concrete depth because surface vibrators act from the top down. They are most effective on slabs less than about 200 mm thick. With slabs greater than 200 mm in thickness, immersion vibrators should be used to supplement the surface vibration. A thick slab compacted by both immersion and surface vibrators will have a denser, more abrasion-resistant surface than one compacted by immersion vibrators alone.

With centrally mounted vibration units, the degree of compaction achieved may vary across the width of the beam. When they rest on edge forms, the latter may tend to damp the

vibration at the extremities of the beam (**Figure 13.8**). It is generally desirable, therefore, to supplement vibrating-beam compaction by using immersion vibrators alongside edge forms and at construction joints – particularly for paving >150 mm thickness (**Figure 13.9**).

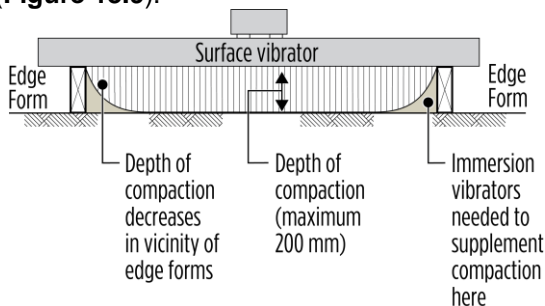

Figure 13.8 – Degree of Compaction varies across Width when Surface Vibrators are supported Off Edge Forms



Figure 13.9 – Use of an Immersion Vibrator at a Slab Edge

The effectiveness of vibration (and hence the degree of compaction) increases with an increase in the beam weight and the amplitude and the frequency and decreases with an increase in forward speed. Forward speed is critical when using a vibrating-beam screed and should be limited to between 0.5 m/minute and 1.0 m/minute.

Generally, vibrating-beam screeds are not suitable for concretes with slumps greater than about 75 mm as an excessive amount of mortar may be brought to the surface. Ideally,

they should be used on concrete with slumps between 25 mm and 50 mm.

For the reasons noted above, slabs 200 mm in thickness or above should be compacted initially with immersion vibrators. Slabs of less than 200 mm thickness may also benefit from the use of immersion vibrators along their edges (**Figure 13.9**). In using vibrating-beam screeds to compact concrete, the uncompacted concrete should first be roughly levelled above the required final level (i.e. a surcharge should be created) to compensate for the reduction in slab thickness caused by the compaction of the concrete. The amount of surcharge should be such that, when the beam is moved forward, a consistent 'roll' of concrete is maintained ahead of the beam. An even surcharge may be provided on slabs of up to about 4 m in width by using a 'surcharge-beam' – simply a straightedge (usually made of timber) with small packing pieces on the ends, which 'ride' on the edge forms (**Figure 13.10**).

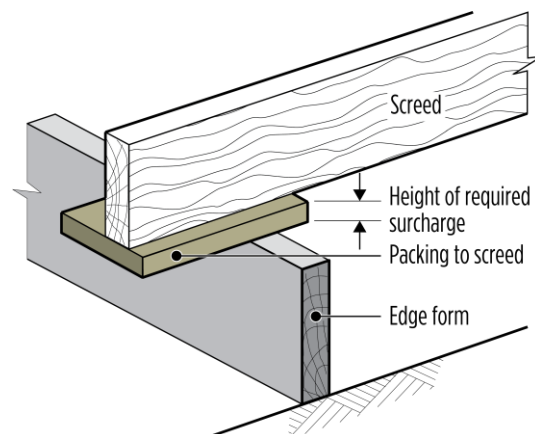

Figure 13.10 – Method of providing an Even-Surcharge of the Uncompacted Concrete

The surcharge-beam is pulled over the uncompacted concrete without any attempt being made to compact or finish it. The sole purpose is to provide an even and adequate surcharge. The correct thickness for the packing pieces (and hence the surcharge) is found by observing the thickness of the 'roll' of concrete. Providing an even surcharge has the advantage that only one pass of the vibrating-beam screed is generally sufficient to compact, level and provide the initial finish. This is preferable to multiple passes, as a slower

single pass is more efficient and effective than two faster passes.

The forward speed is very important and, as noted previously, should be between 0.5 m/minute and 1.0 m/minute. The lower speed should be used for thicker slabs and where reinforcement is close to the top face. A second, faster pass may be made as an aid to finishing.

6.4 FORM VIBRATORS

Form vibrators are normally called 'external' vibrators and are useful with complicated members or where the reinforcement is highly congested. They are clamped to the outside of the formwork and vibrate it, thus compacting the concrete contained inside the form (**Figure 13.11**).

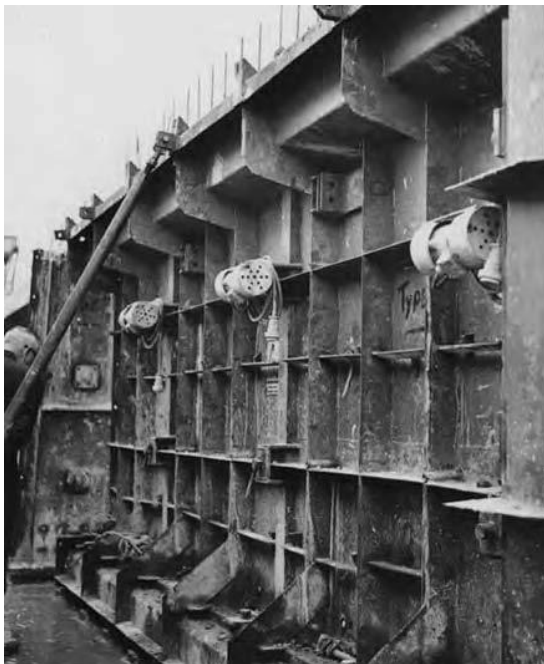

Figure 13.11- Electric Form Vibrators attached to the Steel Formwork of a Bridge Girder

Since form vibrators impose large forces on the formwork it requires special design and construction methods. Determining the positioning of the vibration units requires skill and experience. For all these reasons, the use of form vibrators is most common in the manufacture of precast members and products in a factory environment.

When consideration is being given to using form vibrators, the fact that air bubbles tend to migrate towards the source of vibration should be understood. Hence, if a high standard of off-form surface finish is important, careful consideration must be given to the location of form vibrators.

For some products, formwork may be clamped to a vibrating table – i.e. a rigid unit isolated from its supports by springs, neoprene pads or similar means – which is set in motion by vibrators attached to it. The whole unit, including the formwork, then vibrates to compact the concrete. These units are most commonly used in the manufacture of concrete products, where, with very stiff mixes, pressure may also be applied to the surface of the unit to compact it (e.g. the manufacture of concrete blocks).

7. UNDER-VIBRATION AND OVER-VIBRATION

Normal-weight concretes, which are well proportioned, are not readily susceptible to defects caused by over-vibration. If they occur, such defects result from segregation and are characterised by an excessive thickness of mortar on the surface of the concrete. The surface may also have a frothy appearance. Over-vibration may cause problems when grossly oversized vibration equipment is operated for an excessive length of time but is more likely to be problematic with poorly proportioned mixes or those to which excessive amounts of water have been added.

When signs of over-vibration are detected, the initial reaction may be to reduce the amount of vibration. The proper solution is to adjust the mix design.

Under-vibration is far more common than over-vibration and, when it occurs, can cause serious defects. Invariably, under-vibrated concrete is incompletely compacted which reduces its strength, its durability and possibly adversely affects its surface finish.

Despite this, many specifications contain a caution against over-vibration (and even define a length of time for vibration that must not be

exceeded) while neglecting totally the question of under-vibration.

8. REVIBRATION

Re-vibration of concrete is the intentional systematic vibration of concrete which has been compacted some time earlier. It should not be confused with the double vibration that sometimes occurs with the haphazard use of immersion vibrators or multiple passes of a vibrating-beam screed.

While it is generally agreed that re-vibration of concrete can be beneficial to its strength, its bond to reinforcement and its surface finish, the practice is not widely used, partly due to the difficulty of knowing just how late it can be applied. A good 'rule of thumb' is that re-vibration may be used as long as the vibrator is capable of liquefying the concrete (and sinking into it under its own weight).

Situations in which re-vibration may be beneficial include:

- To bond layers of concrete into those preceding them. In elements such as walls, deep beams and columns, which are being filled in successive layers, the vibrator should penetrate the previous layer;
- To close plastic shrinkage and settlement cracks. These form within the first few hours of concrete being placed and can sometimes be closed by vibration. However, a reasonable level of energy input is required since mere reworking of the surface may simply close the cracks superficially. They will then reopen as the concrete dries out;
- To improve the surface finish at the tops of columns and walls by expelling the air which tends to congregate there as the concrete settles in the formwork;
- To improve the wear resistance of floors. Re-vibration, coupled with hard-trowelling, helps to create a dense wear-resistant surface layer.

9. SUMMARY: SURFACE DEFECTS FROM CONCRETE PLACEMENT AND COMPACTION

Defects	Causes		
	Plastic Concrete Properties	Placement	Compaction
Honeycombing	Insufficient fines, low workability, early stiffening, excessive mixing, too large an aggregate for placing conditions.	Excessive free fall, too thick a layer (lift) of concrete in forms, drop chute omitted or of insufficient length, too small a tremie, segregation due to horizontal movement.	Vibrator too small, too low a frequency, too small an amplitude, too short immersion time, excessive spacing between immersions, inadequate penetration.
Air surface voids	Lean sand with a high FM, low workability with low FM sand, excessive cement content, particle degradation, excessive sand, high air content.	Too slow, caused by inadequate pumping rate, undersized bucket.	Too large an amplitude, external vibration inadequate, head of vibrator only partially immersed.
Form streaking	Excess water or high slump.	Improper timing between placing and timing.	Excessive amplitude or frequency for form design.
Aggregate transparency	Low sand content, gap-graded aggregate dry or porous, excessive coarse aggregate, excessive slump with lightweight concrete.		Excessive external vibration, over-vibration of lightweight concrete.
Subsidence cracking	Low sand, high water content, too high slump, poorly proportioned mix.	Too rapid.	Insufficient vibration and lack of re-vibration.
Colour variation	<ul style="list-style-type: none"> Non-uniform colour of materials, inconsistent grading, variation in proportions, incomplete mixing; Calcium chloride can cause darker colour; Variable or too high a slump. 	Segregation (slump too high).	Vibrator too close to form, vibration next to forms variable, over-working of the concrete.
Sand streaking	Lean over-sanded mixtures and harsh wet mixtures deficient in fines.	Too rapid for type of mix.	Excessive vibration, excessive amplitude, over-working the concrete.
Layer lines	Wet mixture with tendency to bleed.	Slow placement, lack of equipment or manpower.	Lack of vibration, failure to penetrate into previous layer.
Form offsets	Excessive retardation of time of setting of concrete.	Rate too high.	Excessive amplitude, non-uniform spacing of immersion, horizontal movement of concrete.
Cold joints	Too dry, early stiffening, slump loss.	Delayed delivery, layers (lifts) too thick.	Failure to vibrate into lower layer (lift), insufficient vibration.

NOTE: Adapted from ACI Committee 309 Report 'Consolidation-Related Surface Defects ACI 309.2R – 98', ACI Manual of Concrete Practice, Part 2.

10. RELEVANT AUSTRALIAN STANDARDS

- 1) AS 1379 – *Specification and supply of concrete*
- 2) AS 3600 – *Concrete structures*

This section provides information on the finishing of freshly placed concrete. Generally, compaction (see Section 13 'Compaction') and finishing are two separate operations; however, on flat horizontal surfaces (flatwork), they are often part of the same operation and can be considered together. Applied and off-form finishes for vertical and inclined surfaces are discussed in Section 27 'Formwork'.

CONTENTS

1. INTRODUCTION	2
2. GENERAL	2
3. LEVELLING (SCREEDING)	3
3.1 GENERAL	3
3.2 HAND SCREEDING OFF FORMS OR SCREED RAILS	3
3.3 HAND SCREEDING OFF 'WET SCREEDS'	3
3.4 SCREEDING USING VIBRATING- BEAM SCREEDS	3
3.5 MACHINE-MOUNTED SCREEDS (LASER SCREEDS)	4
4. FLOATING	4
4.1 GENERAL	4
4.2 BULLFLOATING	5
4.3 FLOATING BY HAND	5
4.4 FLOATING BY MACHINE	6
5. TROWELLING	7
5.1 GENERAL	7
5.2 TROWELLING BY HAND.....	7
5.3 TROWELLING BY MACHINE	7
6. EDGING	7
7. SURFACE TREATMENT	8
7.1 GENERAL	8
7.2 'DRIERS' AND 'DRY-SHAKE TOPPINGS'	8
7.3 ABRASION-RESISTANT TOPPINGS	8
7.4 SLIP AND SKID RESISTANCE.....	9
7.5 CHEMICAL RESISTANCE.....	9
7.6 COLOURED CONCRETE	9
7.7 TEXTURING.....	10
7.8 IMPRINTING.....	10
8. TOLERANCES	11

9. REFERENCES	12
----------------------------	-----------

10. RELEVANT AUSTRALIAN STANDARDS	12
---	-----------

1. INTRODUCTION

In this section the techniques used to finish flat horizontal surfaces after the concrete has been compacted are described and discussed.

The compacting and finishing of concrete are generally two separate operations but, as noted above, sometimes (particularly with flat horizontal surfaces) they become part of the one operation. In such circumstances, it must always be remembered that a smooth surface finish is not necessarily evidence of good compaction underneath it. Care must always be taken to ensure that concrete is properly compacted.

2. GENERAL

'Flatwork' refers to a wide range of concrete floors or paving, and includes industrial floors, floors in commercial and domestic buildings (both on-ground and suspended), paths, patios, driveways and roads.

The finishing of flatwork involves a sequential combination of the following processes:

- Levelling;
- Floating;
- Trowelling;
- Other treatments.

These operations are carried out largely while the concrete is still plastic. The purpose of finishing is to achieve the desired:

- Level or profile;
- Flatness;
- Surface density and texture.

3. LEVELLING (SCREEDING)

3.1 GENERAL

Levelling or screeding is the initial operation carried out on a concrete slab after the plastic concrete has been placed in the forms and (if necessary) roughly levelled by shovel. Screeding is carried out by (a) working a beam backwards and forwards across the concrete to achieve a level surface or (b) by means of vibrating-beam screeds working off forms or guide rails. Levelling / screeding should be done before bleed water rises to the surface.

Usually, the final surface will be 'level', but the same screeding technique can be used on sloping surfaces, e.g. for driveways and ramps. In this case, the screeding should be commenced at the lower end and proceed up the slope.

3.2 HAND SCREEDING OFF FORMS OR SCREED RAILS

Screeding off edge-forms involves the use of a screed board to strike off the concrete to the height of the forms. Screed rails are temporary guides to support the screed board. These rails have to be removed after the surface is screeded, and the surface 'made good' while the concrete is plastic.

The striking surface of a screed board should always be straight and true. Proprietary screed boards such as hollow magnesium straightedges should be used for major commercial work and for house slabs. Lengths of dressed timber are satisfactory for minor work.

To enable it to be worked backwards and forwards without losing its level, the straightedge should be between 300 mm and 600 mm longer than the greatest distance between the edge-forms.

The surface is struck off by pulling the screed board forward along the slab, while moving it back and forth with a saw-like motion across the top of the edge forms. A small 'roll' of plastic concrete should always be kept ahead of the straightedge to ensure no hollows are left in the screeded surface and to maintain a plane surface. Excessive amounts of plastic concrete

should be removed and placed ahead of the screed board.

3.3 HAND SCREEDING OFF 'WET SCREEDS'

'Wet-screeds' consist of pads or narrow strips of concrete (approximately 200 mm wide) placed to the correct level in advance of the main pour. The concrete finisher then uses these pads or strips as a height guide for levelling the slab.

This method allows large areas to be screeded without intermediate forms or guide rails being employed and without the necessity to accurately level the edge forms. However, this approach requires more skill and the availability of surveying equipment to accurately set the heights of the 'wet screeds'.

Generally, proprietary aluminium or magnesium screed boards with a handle are preferred for this type of work.

3.4 SCREEDING USING VIBRATING-BEAM SCREEDS

Vibrating-beam screeds provide significant compaction in addition to their screeding capability. Their use and operation are described in Section 13 '*Compaction*'.

The accuracy of the surface level achieved is dependent on the formwork on which the vibrating-beam 'rides'. This formwork must therefore be accurately levelled and firmly fixed so that it will not distort under the weight of the vibrating-beam. Special care should be taken to stabilise joints in formwork boards.

The screed itself should not 'sag' or distort under the weight of the vibration unit and, for this reason, a 4 m width is about the maximum limit for twin-beam, centrally mounted vibration unit screeds. However, trussed vibrating-beam screeds can span 20 m with minimal 'sag' and can be used to provide floors or pavement with very tight surface tolerances (**Figure 14.1**).

3.5 MACHINE-MOUNTED SCREEDS (LASER SCREEDS)

A more recent development in mechanising the screeding and compacting of concrete floors and pavements is the 'laser screed'. These four-wheel drive machines are positioned and then stabilised on hydraulically extended legs (**Figure 14.2**). The telescopic arm with the screed at the end is extended. The concrete is spread by auger and compacted by the screed as the arm is retracted towards the machine.

Laser sensors mounted at the ends of the screed monitor the level and adjust the height automatically. The machines are able to produce floors to very stringent requirements in terms of flatness and accuracy of the level. There are machines of varying size, with screeds up to approximately 4 m wide and the telescoping arms able to extend out to approximately 6-8 m.



Figure 14.1 – Typical Trussed Vibrating Beam Screed

4. FLOATING

4.1 GENERAL

The purpose of 'floating' a concrete surface is to impart to it a relatively even but still open texture in preparation for other finishing operations, and particularly to:

- Embed large aggregate particles beneath the surface;
- Remove slight imperfections and produce a surface closer to the true plane;

- Compact the concrete and consolidate the mortar at the surface in preparation for other finishing operations;
- Close minor surface 'cracks' which might appear as the surface dries.

Two distinct 'floating' operations are carried out. The first of these is carried out after the recently placed concrete has been screeded and before bleed water appears on the surface. The second floating operation is carried out after bleeding has ceased and prior to final finishing.

The initial floating operation is carried out with a 'bullfloat' or 'darby'. The second floating operation is carried out by working the surface

of the concrete with hand floats, or by rotary finishing machines fitted with appropriate floats or shoes. The second operation should not begin until all bleed water has evaporated from the surface, or has been removed with a hessian drag, and the concrete has begun to

harden to the point where, when the finisher walks on it, they leave only minor indentations in the surface. Such indentations should be removed by the floating operation.



Figure 14.2 – Typical Machine-mounted Beam Screed

4.2 BULLFLOATING

The bullfloat is a large float on a long handle which is worked back and forth on the concrete surface in a direction parallel to the ridges formed by screeding, i.e. transversely across the slab (**Figure 14.3**). The blade is typically aluminium or magnesium but may also be made of wood. The blade and handle are usually pivoted so that the angle of the blade can be changed depending on whether the stroke is forward or backward.



Figure 14.3 - Bullfloating

Bullfloating is particularly useful as an initial floating operation to smooth the concrete surface and embed any large aggregate pieces. It is typically carried out immediately after screeding and should be completed before bleed water appears on the surface.

To minimise the number of ridge marks left at the edge of the blade, bullfloat passes should not overlap by more than 50 mm.

A second use of the bullfloat may sometimes be required but care should be taken not to overwork the surface.

4.3 FLOATING BY HAND

Three types of hand float are in common use: wooden, magnesium and composite.

Wooden floats require skilled operators and timing is important. If used too early, they stick or dig in and can tear the surface. If used too late, they can roll the coarser particles of fine aggregate out of the surface.

Magnesium floats require less effort and will not roll coarse particles of fine aggregate out of the surface. They can be used after wood or power floating to give a more uniform swirl finish which creates a smoother texture than that produced by a wooden float.

Well-worn magnesium floats should be discarded. They develop an edge almost as sharp as that of a steel trowel, and use of them risks closing the surface too soon.

Composite floats have resin-impregnated canvas surfaces. They are smoother than wooden floats but slightly rougher than magnesium floats. They also can be used after wood or power floating.

The hand float is held flat on the surface and moved in a sweeping arc to embed the aggregate, compact the concrete, and remove minor imperfections and cracks. Sometimes, the surface may be floated a second time, after some hardening has taken place, to impart the final desired texture to the concrete (**Figure 14.4**).

4.4 FLOATING BY MACHINE

Machines for floating are usually trowelling machines with float shoes or, for use on low-slump concrete or toppings, disc-type machines (Kelly floats).

Float blades are wider than trowel blades and are turned up along the edges to prevent them digging into the surfaces whilst in the flat position. For this reason, floating with a trowelling machine equipped with normal trowel blades should not be attempted.

The power-float should be operated over the concrete in a regular pattern leaving a matt finish (**Figure 14.5**).

Concrete close to obstructions or in slab corners that cannot be reached with a power-float should be manually floated before power floating is begun.

The use of water sprays or other means of wetting the surface during finishing operations should not be permitted as such practices

almost inevitably cause dusting of the slab when placed into service.



(a)



(b)

Figure 14.4 - Hand Floating (a) and Edging (b) are Important Finishing Tasks



Figure 14.5 – Power Floating in a Regular Pattern

5. TROWELLING

5.1 GENERAL

Trowelling is carried out some time after floating. The delay is to allow some stiffening to take place so that aggregate particles are not torn out of the surface when trowelling.

For a first trowelling, the trowel blade should be kept as flat against the surface as possible since tilting or pitching the trowel at too great an angle can create ripples in the concrete.

Additional trowelling may be used to increase the smoothness, density, and wear resistance of the surface. Successive trowelling passes should be made with smaller trowels pitched progressively higher. This increases the pressure at the bottom of the blade and helps compact the concrete surface.

The formation of blisters on the surface during trowelling indicates that the angle of the trowel is too great. As soon as blisters are seen they should be pushed down immediately and re-bonded to the base concrete using a magnesium float or a flat trowel – depending on the stiffness of the concrete. The angle of the trowel should then be reduced to prevent more blisters from forming.

NOTE: A blistered surface will not be durable. Blisters can be broken out by traffic movement and will reflect through any hard tile placed over them.

5.2 TROWELLING BY HAND

A trowel for hand finishing has a flat, broad steel blade and is used in a sweeping arc motion with each pass overlapping the previous one.

The timing for trowelling to be most effective requires some experience and judgement, but as a guide, when the trowel is moved across the surface it should give a ringing sound.

5.3 TROWELLING BY MACHINE

The trowelling machine (power trowel or 'helicopter') is a common tool for all classes of work and consists of several (generally four) steel trowel blades rotated by a motor and

guided by a handle. Larger machines are ride-on and are suitable for trowelling large areas such as factory floors (**Figure 14.6**).



Figure 14.6 – Multi-head power Trowel Machines are commonly used for Major Warehouse Projects

Trowelling by machine should be carried out systematically over the concrete in a regular pattern. Corner areas, areas close to obstructions and small irregularities should then be 'touched-up' with a hand trowel.

Successive trowelling passes, with a break to allow further hardening, will 'densify' the surface, providing increased wear resistance. Any successive trowelling passes should be at right angles to the previous pass for maximum effectiveness.

6. EDGING

Edging (**Figure 14.4**) provides a quarter-round *arris* along the edges of footpaths, patios, curbs and steps. It is achieved by running an edging trowel around the perimeter of the concrete. Edging trowels are steel (or brass) and incorporate a quarter-round forming edge. They are available in a variety of widths and with various diameter quadrants.

Edging improves the appearance of many types of paving and makes the edges less vulnerable to chipping. However, edging should not be used at joints in industrial or warehouse floors or in floors which will be tiled or carpeted.

Joints in industrial floors should have a crisp right-angled corner. On formed edges this is achieved principally by the form boards which should have sharp, right-angled edges. Hand

trowelling is generally used along such edges to ensure the sharpness of corners.

7. SURFACE TREATMENT

7.1 GENERAL

Surface treatments should be chosen to suit the anticipated service conditions or to give the concrete a particular appearance.

The choice of finish will be influenced by the following considerations:

- The type of traffic and its frequency;
- Whether the floor is subject to impact-loading;
- Whether chemicals will come into contact with the slab.

Consideration should also be given to the operations to be carried out on the floor, which may determine how smooth it should be, and the necessity for hygiene and the management of dust.

Surface treatments which can be used to provide different appearances include colouring, exposing the aggregate and texturing or imprinting.

7.2 'DRIERS' AND 'DRY-SHAKE TOPPINGS'

A difficult question relating to concrete floor finishing is whether to permit the use of 'dry-shake toppings', and if so, under what conditions. Their use to mask or patch up an unsatisfactory finish should not be permitted. However, when used by a skilled finisher, they can impart special finishes to flatwork (e.g. coloured and abrasion-resistant surfaces). In the hands of a skilled finisher, they may also be useful for correcting minor imperfections in a surface.

As a general rule it is necessary for there to be agreement between placer and customer, before finishing commences, as to whether dry shakes will be permitted and if so, under what circumstances.

When 'driers' (neat cement or mixtures of cement and sand) are used to soak up bleed

water, the surface will almost certainly have a variable water/cement ratio resulting in poor wear resistance and they should not be used. If used the finished surface will almost certainly exhibit crazing and in extreme cases may delaminate.

'Dry-shake toppings' have been used to 'mask' concrete which is not of the correct quality and/or which has been poorly placed and compacted. Although the surface might appear 'hard' in the first instance the base concrete will be inadequate for the purpose for which it was intended.

7.3 ABRASION-RESISTANT TOPPINGS

The appropriate wear (abrasion) resistance, impact resistance and chemical resistance of flatwork is generally achieved by specifying the appropriate strength of concrete and properly compacting, finishing and curing it.

Since the wear resistance of concrete is directly related to its compressive strength, AS 3600 stipulates minimum requirements for resistance to abrasion as shown in **Table 14.1**.

Where very high levels of wear resistance are required, metallic dry shakes can be used to good effect. They consist of cement mixed with either specially treated malleable graded iron filings, or a mixture of carborundum (silicon carbide) and emery particles. Similarly, the incorporation of steel fibres in the concrete mix can increase wear resistance.

The application of metallic dry shakes and subsequent finishing of the concrete is a skilled operation, usually performed by specialist operators. The metallic dry shake is distributed over a floated concrete surface. The surface is then floated again and may then be trowelled. If steel fibres are used in the mix, they can affect concrete workability and finishing.

Table 14.1 – Strength Requirements for Abrasion
(from Table 4.6 in AS 3600)

Member and/or traffic	Minimum characteristic compressive strength, f'_c (MPa)
Footpaths and residential driveways	20
Commercial and industrial floors not subject to vehicular traffic	25
Pavements or floors subject to:	
(a) Pneumatic-tyred traffic	32
(b) Non-pneumatic-tyred traffic	40
(c) Steel-wheeled traffic	To be assessed, but not less than 40.

The use of surface hardeners – such as products based on sodium silicate or silico-fluoride compounds – may provide some additional wear resistance but should not be used to justify lower grades of concrete than those specified in AS 3600. Whilst having some effect during the early life of a floor, re-application of these compounds will be necessary as the floor wears.

7.4 SLIP AND SKID RESISTANCE

Slip and skid-resistant concrete surfaces can be created by texturing the plastic concrete. The term 'slip' relates to pedestrian surfaces, while 'skid' is the term used for vehicular pavements. Finishing the concrete with a wooden or sponge float will give the surface a degree of slip resistance. Such surfaces will be suitable for foot traffic on level or near-level paving.

AS/NZS 4586 sets out required slip resistance for various areas in domestic and pedestrian areas. Bowman [1] provides a detailed discussion of the topic of slip resistance and an explanation of how to use the Standard.

A stiff-bristled broom or dampened hessian sheet, drawn across the trowelled surface, can

produce a greater degree of skid-resistance suitable for vehicular traffic.

For greatest skid-resistance, on ramps or high-speed roadways, freshly trowelled concrete can be grooved with steel *tynes* (see also under *Texturing* below).

7.5 CHEMICAL RESISTANCE

Good quality concrete can withstand attack from many chemicals. Provision of a high grade of concrete properly placed, compacted, finished and cured is generally the best way to provide maximum chemical resistance. In some cases, chemical resistance may be further increased by the use of surface hardeners such as sodium silicate, silico-fluoride compounds or other protective coatings. Where the surface is subjected to attack from very aggressive chemicals (e.g. agents containing inorganic or organic acids) the use of a suitable protective coating is required. Such coatings should be applied after the concrete has been properly cured but before it is exposed to the chemical attack. (For further guidance on this topic see Section 25 '*Properties of Concrete*').

7.6 COLOURED CONCRETE

Concrete can be coloured by incorporating a pigment into the concrete mix. As pigments are expensive it has been common to apply a dry-shake topping containing a pigment onto normal 'uncoloured' concrete surfaces.

The dry shake consists of a mix of cement, oxide pigment and clean, sharp sand. Typical proportions are 1-part cement / 0.06 to 0.1-part oxide / 2-parts clean, sharp sand. The exact proportion of oxide depends on the shade required. If too little oxide is used a washed-out colour will be obtained in the final finish. Using oxide at levels >10% of cement content adds no extra colour as at this addition level, colour saturation has been reached.

All components of the dry-shake mix should be thoroughly blended before use. The pigment and cement are initially mixed together, and then the sand is added.

Timing is crucial when coloured dry shakes are applied. All bleeding should have ceased and the water sheen on the concrete should no longer be visible. The dry-shake mix is then broadcast over the surface sufficiently thickly to produce a topping 3-4 mm thick. It is then floated and trowelled onto the concrete without the surface being overworked. The most consistent colour outcome is obtained when about two-thirds of the dry-shake material is applied in one direction and then the remainder applied at 90° to the first pass.

7.7 TEXTURING

Useful textures can be obtained using brooms of varying degrees of stiffness, as well as hessian or sponges. These can produce finishes which are both functional and attractive.

Brooms may be used to provide a variety of textures. The timing of brooming and the angle at which the broom is held will affect the appearance. An extension handle is usually fitted so that the broom can be pulled right across the surface in one motion and, after each traverse of the concrete, the broom head should be tapped or cleaned to prevent an accumulation of mortar in the bristles.

Where a broomed texture is used and traffic is heavier than domestic or light commercial traffic, the texture should be deeper. Lightly broomed textures look attractive when first done but wear quickly in industrial situations, whereas a medium or coarse broom texture should provide a good, skid-resistant surface over the design life of the floor or pavement (**Figure 14.7**).

Tyning is used in applying a skid-resistant surface on concrete road paving. Immediately after the paving machine has completed its function, a separate tyning machine places a skid-resistant finish by drawing a 'rake' system across the surface of the paved concrete – usually in an orientation transverse to the direction of the paving.

Exposed aggregate finishes are achieved by washing away the top layer of cement mortar from the surface of the concrete once initial

setting has taken place. Timing is crucial to achieving a good exposed aggregate finish.

The surface of cement paste is generally removed with a fine water spray, supplemented by light brooming with a soft brush.



Figure 14.7 – Broom Finishing helps to provide Skid Resistance

Concrete mixes may be 'modified' for exposed aggregate finishes (e.g. by increasing the proportion of the size of aggregate which it is desired to feature).

Where a 'special' aggregate is to be exposed, this can be spread evenly (broadcast) over the levelled concrete and tamped into the surface which is then floated. After a delay to allow some hardening to take place the cement paste on the surface is washed away to expose the aggregate. To ensure a durable surface, less than one third of the diameter of the stones should be exposed.

7.8 IMPRINTING

Imprinting or 'pattern paving' provides a wide range of texturing possibilities – including slate

and brick look-alikes. The usual technique is for the concrete to be placed, compacted, bullfloated and a coloured dry-shake topping applied. The surface is then covered with plastic sheeting or a release agent and the patterning moulds are systematically stamped into the surface. On completion of stamping the moulds (and plastic) are removed and the surface is lightly broomed and subsequently cured. Any de-bonding agent used is washed off before applying a 'sealer' which helps provide a uniform colour and often gives a wet or polished look to the surface.

It should be noted, however, that skill and experience are generally necessary to achieve satisfactory results with this type of finish.

8. TOLERANCES

The tolerances specified for the surfaces of slabs or other flatwork should be appropriate to their final use. Achieving tight tolerances increases costs. It may be necessary, for example, to have tight tolerances in warehouses with high-racking bays but it would be unnecessarily expensive to have very tight tolerances for loading dock areas where the delivery trucks are received.

AS 3600 specifies floor tolerances to ensure that structural behaviour is not impaired. It does not specify tolerances for the serviceability or usefulness of the floor.

Floors generally have to meet two independent tolerance criteria. One deals with the desired elevation and the other with the 'flatness' of the floor.

The 'elevation tolerance' gives the permitted variation of the slab surface from a fixed external reference point or datum.

For pavements requiring very high tolerances (e.g. warehouses in which loosely stacked items are moved on forklift pallets) reference should be made to the CCAA Technical Note (T48) '*Guide to Industrial Floors and Pavements*' [2].

9. REFERENCES

- 1) Bowman, R. *'An Introductory Guide to the Slip Resistance of Pedestrian Surface Materials'* (HB 197) CSIRO and Standards Australia (1999)
- 2) *'Guide to Industrial Floors and Pavements – Design, Construction and Specification'*, Cement Concrete and Aggregates Australia, Technical Note T48 (2009)
- 3) CCAA, *'Guide to Concrete Flatwork Finishes'*, CCAA T59 (2008)

10. RELEVANT AUSTRALIAN STANDARDS

- 1) AS 1379 – *Specification and supply of concrete*
- 2) AS 3600 – *Concrete structures*
- 3) AS/NZS 4586 – *Slip resistance classification of new pedestrian surface materials*

This section describes aspects of the curing of concrete, providing (a) a review of the cement hydration reaction to highlight the fundamental importance of keeping concrete moist during its early life; (b) a discussion describing the effect of curing (and its absence) on the properties of concrete; and (c) a description of the methods which can be used to cure concrete under the wide variety of conditions found on building and construction sites.

CONTENTS

1. INTRODUCTION	2
2. HYDRATION OF CEMENT	3
2.1 GENERAL	3
2.2 EFFECT OF TEMPERATURE.....	3
3 EFFECT OF DURATION OF CURING ON PROPERTIES OF CONCRETE	4
3.1 EFFECT ON STRENGTH	4
3.2 EFFECT ON DURABILITY.....	4
4 CURING METHODS	6
4.1 GENERAL	6
4.2 IMPERMEABLE-MEMBRANE CURING	6
4.3 WATER CURING.....	8
4.4 ACCELERATED CURING.....	9
5 SELECTING A METHOD OF CURING .	10
6 SUMMARY – CONSIDERATIONS WHEN SELECTING A CURING METHOD	11
7 REFERENCES	13
8 RELEVANT AUSTRALIAN STANDARDS	13

1. INTRODUCTION

Curing is the process or activity that is used to control the loss of moisture from concrete after it has been finished (or in the case of concrete products, after manufacture), thereby providing time for the ongoing hydration of the cement to occur. Since the hydration of cement takes time (days and weeks – not just hours) curing must be undertaken for a moderate period of time if the concrete is to achieve its full potential strength and durability performance. The curing process may also encompass the control of temperature since it also affects the rate at which cement hydrates.

The curing period will depend on (a) the properties required of the concrete, (b) the purpose for which it is to be used, and (c) the ambient conditions (i.e. the temperature and relative humidity of the surrounding atmosphere).

Since curing is designed primarily to keep the concrete moist by preventing the loss of water from surface of the concrete while it is gaining strength, it may be done in two ways:

- By preventing an excessive loss of moisture from the concrete for a certain period of time, e.g. By leaving formwork in place, covering the concrete with an impermeable membrane after the formwork has been removed, or by a combination of such methods; or
- By maintaining a continuously wet surface thereby preventing the loss of moisture from it – where ponding or spraying the surface with water are methods typically employed.

In the manufacture of concrete products, the temperature of the concrete is usually raised to accelerate the rate of strength gain. Very importantly, the concrete must be kept moist during such treatment. Curing the concrete in saturated steam or curing it with high-pressure steam in a suitable container (e.g. an autoclave) are methods used to cure concrete at elevated temperatures. Other methods that can be used include (a) the use of hot flue or exhaust gases, (b) the use of heated formwork, and (c) electrical curing. These methods are only rarely used and will not be elaborated upon in this Guide. Some of the heating methods are commonly used in countries with colder climates, and although their use is widespread in these countries they are not generally applied in Australia.

2. HYDRATION OF CEMENT

2.1 GENERAL

When water is mixed with general purpose or blended cement a series of chemical reactions commence, which proceed rapidly at first, but then more slowly, and can continue for weeks and months – provided sufficient water is present. These hydration reactions result in new minerals being formed and, as the reaction progresses, the cement paste at first stiffens and then hardens and gains strength.

The details of these reactions will not be fully described in this Section (for further information, see Section 1 ‘Cements’), except to note the following:

- The different minerals in the cement react with water at different rates. Those which are responsible for the early stiffening of the paste and its early strength react quite rapidly but then contribute little to subsequent strength gain;
- Those minerals which contribute most to the strength of the paste and, hence, to the strength of the concrete, react more slowly. As a result, they require the paste to be kept moist while the concrete gains strength;
- Allowing the paste to dry out causes the hydration reactions to cease (for all practical purposes). While rewetting the paste causes the reactions to recommence, the effect on the subsequent strength and other desirable properties of the paste may be permanently impaired or reduced.

Figure 15.1 provides a schematic representation of the chemical reactions which take place when water is mixed with cement, showing (a) the time-dependent nature of these reactions, (b) the increasing amounts of reaction products over time, and (c) the decrease in paste porosity over time.

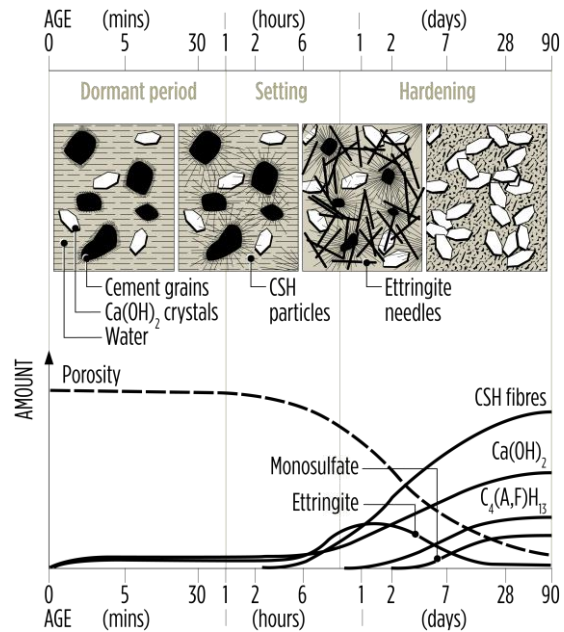

Figure 15.1 – Schematic Representation of Hydration Reactions of Cement and Water

2.2 EFFECT OF TEMPERATURE

The temperature of the cement paste can have a quite marked effect on the rate at which it hydrates. The temperature may also affect the nature of the new compounds formed and, hence, have a permanent effect on the long-term strength and durability of the concrete.

Lower temperatures reduce the rate at which the hydration reactions occur, while high temperatures increase the rate of the hydration reactions. While higher temperatures increase the rate of strength gain, they also reduce the strength of the concrete at later ages.

Figure 15.2 illustrates the effect of curing temperature on the rate of strength gain of concrete. The figure is illustrative only as the magnitude of temperature effects depends on several factors, not the least of which are the composition and fineness of the cement.

For practical purposes, it should be noted that, provided the temperature of the concrete is maintained within the normal range of ambient temperatures encountered in temperate Australia (about 15-30°C), no significant detriment will occur in relation to the strength performance of the concrete. For concrete operations outside this temperature range, i.e. in very hot or very cold weather, special

precautions may be necessary. These are discussed in Section 18 'Hot- and Cold-Weather Concreting'.

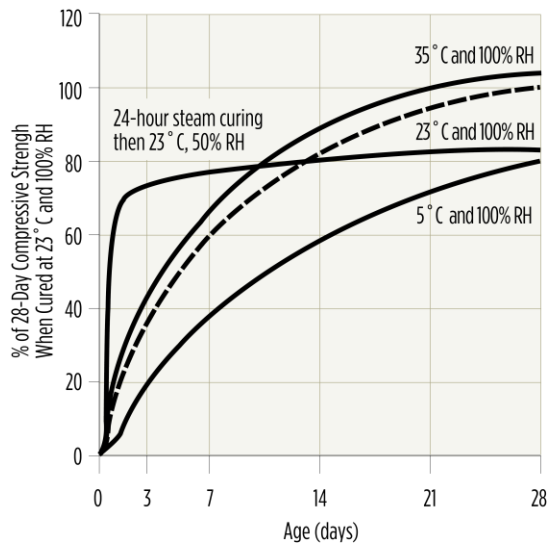

Figure 15.2 – Effect of Curing Temperature on the Rate of Strength Gain of Concrete

3 EFFECT OF DURATION OF CURING ON PROPERTIES OF CONCRETE

3.1 EFFECT ON STRENGTH

As will be discussed in Section 25 'Properties of Concrete', the strength of concrete is affected by a number of important factors, one of which is the length of time for which it is kept moist (i.e. cured) after hardening. **Figure 15.3** illustrates the impact of curing on compressive strength by comparing the compressive strength (at 180 days) of concretes which have been:

- Kept moist for 180 days;
- Kept moist for various periods of time and allowed to dry out; and
- Allowed to dry out (i.e. 'air cured') from the time it was first made.

As can be seen in this example, concrete allowed to dry out immediately achieves only about 40% of the strength of the same concrete water cured for the full period of 180 days. Even three days water curing increases the strength to >60% of the 180-day strength, while 28-day water curing increases it to about 95% of the 180-day strength. A period of moist

curing is clearly an effective way of increasing the ultimate strength of concrete.

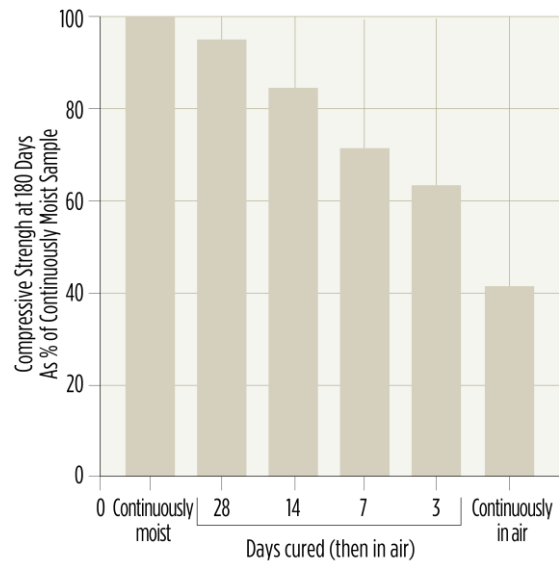

Figure 15.3 – Effect of Duration of Water Curing on Strength of Concrete

3.2 EFFECT ON DURABILITY

The durability of concrete is affected by a number of factors including its permeability and absorptivity (see Section 25 'Properties of Concrete'). Broadly speaking, these are related to the porosity of the concrete and, more particularly, to whether the pores and capillaries are discrete or interconnected. Whilst the number and size of the pores and capillaries in cement paste are related directly to its water/cement ratio, they are also related, indirectly, to the extent of water curing. Over time, water curing causes hydration products to (either partially or completely) fill the pores and capillaries present, and, hence, to reduce the permeability of the paste.

(NOTE: Permeability is a measure of the ability of fluids (i.e. liquids or gases) to flow through a medium. A low permeability coefficient means that fluids have difficulty in passing through the medium.)

Figure 15.4 illustrates the effect of different periods of water curing on the permeability of a cement paste with a W/C ratio of 0.51. As can be seen, extending the period of curing reduces the permeability.

(NOTE: The initial (i.e. time = 0 day) permeability coefficient of concrete with a low W/C ratio (e.g. 0.35) will be much lower than that shown in Figure 15.4; while for a higher W/C ratio (e.g. 0.7)

the initial permeability coefficient will be much higher.)

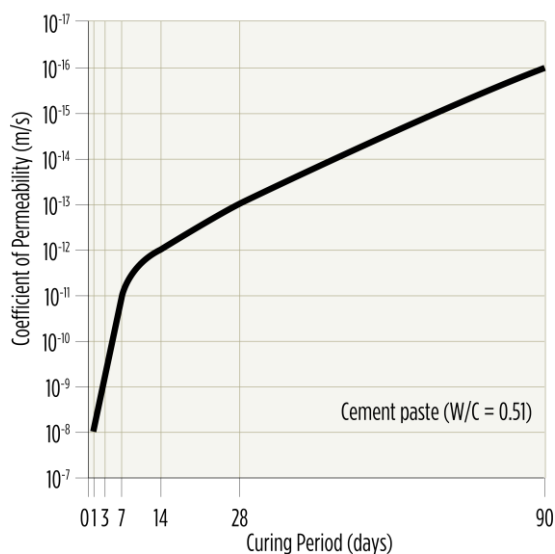

Figure 15.4 – Effect of Duration of Water Curing on the Permeability of Cement Paste

While it is essential that concrete be kept moist for as long as practicable if it is to achieve its potential strength and durability performance, in practice concrete is often not purposefully cured or, at best, is cured for only a very short period of time. This is poor practice as it results in the concrete not achieving its full strength and durability performance. Whilst the effects of inadequate curing are often difficult to determine in the short term, defects such as poor abrasion resistance (i.e. excessive wearing and dusting of floors), unexpected cracking and crazing, and corrosion of reinforcement, are typical outcomes from insufficient curing.

The reality is that the cost of delays to the job or other factors such as the safety of those on site may dictate that curing regimes be maintained for the minimum period necessary for the concrete to achieve its specified properties. Where the effect on required properties cannot be determined precisely (e.g. the effect on concrete durability), an informed estimate should be made to set a minimum curing period.

To safeguard the general quality of concrete construction, AS 3600 sets out the minimum periods for which concrete must be cured. These vary with the strength of the concrete and the conditions to which it will be exposed.

These periods range from three days for the lower exposure conditions (with lower concrete strengths) to seven days for the more severe exposure conditions (with higher concrete strengths) (Table 15.1).

Table 15.1 – Minimum Initial Continuous Curing Periods (from Table 4.4 in AS 3600)

Exposure Classification	Minimum f'_c (MPa, at 28 days)	Minimum Initial Curing Requirement
A1	20	Cure continuously for
A2	25	at least 3 days
B1	32	
B2	40	Cure continuously for
C1	50	at least 7 days
C2	50	

Using water sorptivity as a measure of concrete durability, Figure 15.5 illustrates the effect of the duration of curing for Grade 25 concrete cured in timber formwork. This shows the very significant benefit of curing for three days; the proportionately lesser benefit from extending the curing to seven days; and the minimal additional benefit from extending it beyond seven days.

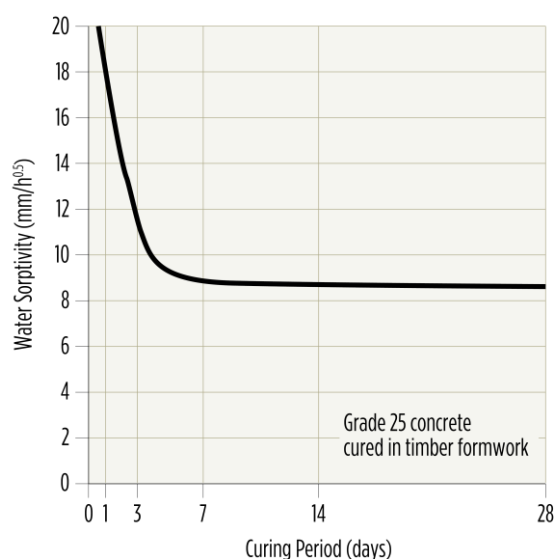

Figure 15.5 – Effect of Duration of Curing on Water Sorptivity of Concrete

4 CURING METHODS

4.1 GENERAL

Methods of curing concrete fall broadly into three categories:

- Those which minimise moisture loss from the concrete by covering it with a relatively impermeable membrane;
- Those which prevent moisture loss by continuously wetting the surface of the concrete;
- Those which keep the surface moist and, at the same time, raise the temperature of the concrete, thereby increasing the rate of strength gain.

4.2 IMPERMEABLE-MEMBRANE CURING

Formwork – Leaving formwork in place is often an efficient and cost-effective method of curing concrete, particularly at early ages. In very hot dry weather, it may be desirable to moisten timber formwork to prevent it drying out during the curing period, thereby increasing the length of time for which it remains an effective means of providing curing.

It is important that any exposed surfaces of the concrete (e.g. the tops of beams) be covered with plastic sheeting or kept moist by other means. It should be noted also that, when vertical formwork is eased from a surface (e.g. from a wall surface), its efficacy as a curing ‘membrane’ is significantly reduced.

Plastic Sheeting – Plastic sheets (or other similar material) form an effective barrier against water loss, provided they are kept securely in place and are protected from damage. Their effectiveness is very much reduced if they are not kept securely in place.

They should be placed over the exposed surfaces of the concrete as soon as it is possible to do so without affecting the finish quality. On flat surfaces (such as pavements) the sheets should extend beyond the edges of the slab for some distance (e.g. for at least twice the thickness of the slab) or be turned down over the edge of the slab and sealed.

For flatwork, sheeting should be placed on the surface of the concrete and, as far as practical, all wrinkles smoothed out to minimise any mottling effects (due to uneven curing) which might otherwise occur. Flooding the surface of the slab under the sheet is a useful way to limit or prevent mottling. Strips of wood (or similar) should be placed across all edges and over joints in the sheeting to (a) prevent wind from lifting it, and (b) to seal in moisture and minimise drying.

For vertical elements, the member should be wrapped with sheeting and taped to limit moisture loss. Where colour of the finished surface is a consideration the plastic sheeting should be kept clear of the surface to avoid hydration staining/mottling. This can be achieved with wooden battens or even scaffolding components – provided that a complete seal can be achieved and maintained.

Care should also be taken to prevent the sheeting being torn or otherwise damaged during use or by site activities. A minimum thickness is required to ensure adequate strength in the sheet with ASTM C171 ‘*Sheet Materials for Curing Concrete*’ specifying 0.10 mm minimum thickness. **Figure 15.6** illustrates the reduced effectiveness of plastic sheeting with holes (and shows that even as little as 1.7% of the sheet’s surface area containing ‘holes’ affects curing effectiveness).

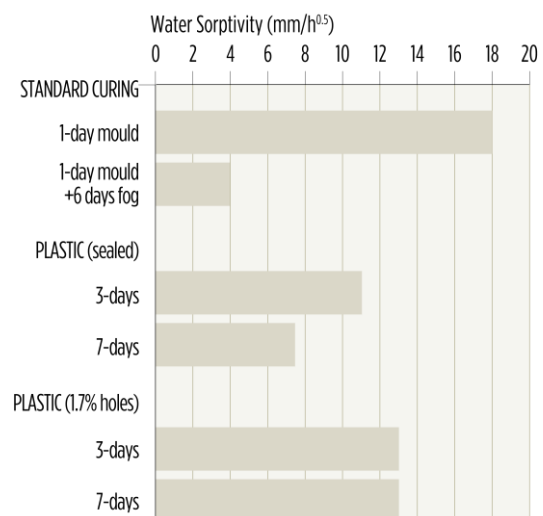

Figure 15.6 – Effectiveness of Plastic Sheet for Curing – Measured by Effect on Water Sorptivity

Plastic sheeting may be clear or coloured. Care must be taken that the colour is appropriate for the ambient conditions. For example, white or lightly coloured sheets reflect the rays of the sun and will help to keep concrete relatively cool during hot weather. Black plastic absorbs heat to a marked extent and may cause unacceptably high concrete surface temperatures. Its use should be avoided in hot weather, although in cold weather its use may be beneficial in accelerating the rate at which the concrete gains strength.

Clear plastic sheeting tends to be more neutral in its effect on temperature (except in hot weather, where it can fail to shade the surface of the concrete) but tends to be less durable than the coloured sheets, thereby reducing its potential for re-use.

Curing Compounds – Curing compounds are liquids which can be brushed, sprayed, or squeegeed (usually sprayed) directly onto concrete surfaces and which then dry to form a relatively impermeable membrane which retards the loss of moisture from the concrete. Their properties and use are described in AS 3799.

They are an efficient and cost-effective means of curing freshly placed concrete or concrete that has been partially cured by some other means. However, they may affect the bond between the concrete and subsequent surface treatments (e.g. paint or renders). Special care in the choice of a suitable compound needs to be exercised in such circumstances, or the surface needs to be cleaned before any surface coatings are applied.

Curing compounds are generally formulated from wax emulsions, chlorinated rubbers, synthetic and natural resins, and from PVA emulsions. Their effectiveness varies quite widely, depending on the material and strength of the emulsion, as is illustrated in **Figure 15.7**.

When used to cure fresh concrete, the timing of their application is critical for maximum effectiveness. They should be applied to the surface of the concrete after it has been finished, as soon as the free water on the surface has evaporated and there is no water sheen visible. Applying too early dilutes the

membrane; applying it too late results in it being absorbed into the concrete surface and not forming a continuous membrane.

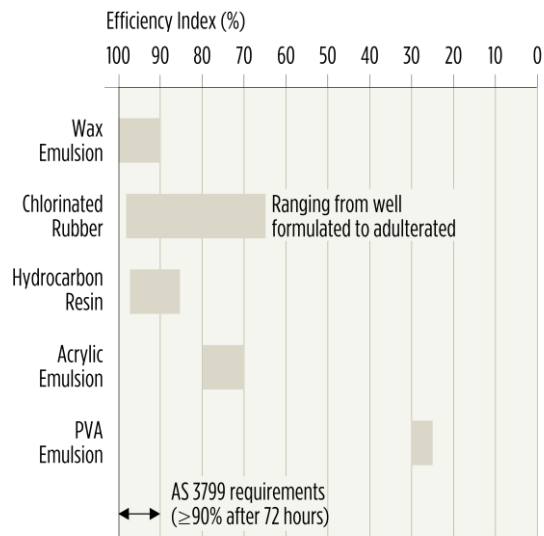

Figure 15.7 – Comparative Efficiency of Curing Compounds

These compounds may also be used to reduce moisture loss from concrete after initial moist curing or the removal of formwork. In both cases, the surface of the concrete should be thoroughly moistened before the application of the compound to prevent its absorption into the concrete.

Curing compounds can be applied by hand spray, power spray, brush or roller. The type or grade of curing compound should be matched to the type of equipment available and the manufacturer's directions followed closely. The rate of application should be uniform with coverage normally in the range of 0.20-0.25 L/m². Where feasible, two applications applied at right angles to each other will help ensure complete coverage and effective protection.

Pigmented compounds also help to ensure complete coverage has occurred and are advantageous in helping concrete surfaces reflect rather than absorb heat. **Figure 15.8** shows pressure spraying of a white-pigmented curing compound.

It should be noted that many curing compounds are solvent based. Adequate ventilation should always be provided in enclosed spaces and other necessary safety precautions taken when using these materials.

Manufacturer's recommendations should always be understood and followed.



Figure 15.8 – Spray Application of Curing Compound

4.3 WATER CURING

General – Water curing is carried out by placing water on the surface of concrete in a manner which ensures that the concrete is kept continuously moist.

The water used for this purpose should not be more than about 5°C cooler than the concrete surface. Spraying warm concrete with cold water may give rise to 'thermal shock' which may cause or contribute to cracking. Alternate wetting and drying of the concrete must also be avoided as this causes volume changes which may also contribute to surface crazing and cracking.

Ponding – Flat or near-flat surfaces such as floors, pavements, flat roofs and the like may be cured by ponding. A 'dam' is erected around the edge of the slab and water is then added to create a shallow 'pond' (Figure 15.9).

Ponding is a quick, inexpensive and effective form of curing when there is (a) a ready supply of good 'dam' material (e.g. clay soil), (b) a supply of water, and (c) the 'pond' does not interfere with subsequent construction operations. It has the added advantage of helping to maintain a uniform temperature on the surface of the slab.

Care should be taken that material used for the 'dam' does not stain or discolour the concrete surface.

Sprinkling or Fog Curing – Using a fine spray (or fog) of water can be an efficient method of supplying additional moisture for curing and, during hot weather, it helps to reduce the temperature of the concrete.



Figure 15.9 – Ponding Method of Water Curing

As with other methods of moist curing, it is important that the sprinklers used keep the concrete permanently wet. However, the sprinklers do not have to be on permanently – they may be controlled by a timer system.

Sprinklers require a major water supply, can be wasteful of water and will probably need a drainage system to handle runoff. This water management system will usually be required to be a 'closed' system where the water is collected and recycled.

Sprinkler systems may be affected by windy conditions and supervision is required to ensure that the whole concrete surface is being kept moist and that no part of it is being subjected to alternate wetting and drying. This is not always easy to achieve.

Wet Coverings – Wetted fabrics such as hessian or materials such as sand can be used to maintain water on the surface of the concrete. The fabric or sand is kept wet with hoses or sprinklers. On flat areas, fabrics may need to be weighed down. Also, it is important to ensure that the whole area is covered.

Wet coverings should be placed as soon as the concrete has hardened sufficiently to prevent surface damage.

Fabrics may be particularly useful on vertical surfaces since they help distribute water evenly over the surface and, even where not in contact

with it, will reduce the rate of surface evaporation. Care should be taken to ensure that the surface of the concrete is not stained by either (a) impurities in the water or (b) by the covering material.

4.4 ACCELERATED CURING

General – Accelerated curing of concrete is designed to increase or accelerate the rate at which the concrete gains strength. Invariably it involves some method of increasing the temperature of the concrete in a controlled way. Control of the rate at which the concrete heats (and cools) is critical to avoid potentially severe losses in ultimate strength and/or cracking of the concrete due to thermal shock.

It is also critical that exposed surfaces of the concrete be kept moist during the curing regime.

Steam Curing – Low pressure steam curing involves the application of saturated steam to concrete in suitable chambers or under removable covers. It is used to heat the concrete and to accelerate the rate of strength gain and is widely used in the precast concrete industry. Its cost is justified by the more-rapid turnaround of formwork and the resulting greater productivity. Strict control of the steaming cycle is critical (**Figure 15.10**). A detailed discussion of the steam-curing process can be obtained from suitable references, e.g. the Concrete Institute of Australia's Recommended Practice [1].

It should be noted that the maximum steam curing temperature allowed (see **Figure 15.10**) will vary with mix cement type. The maximum temperature of 70°C may apply to concrete with a binder containing type GP or HE cement but may be increased where some blended cements are used. The reason for this limit is to reduce the risk of 'Delayed Ettringite Formation' in the concrete.

Autoclaving – Curing with high pressure steam, or autoclaving, refers to the curing of certain concrete products in an atmosphere of saturated steam at temperatures in the range 160-190°C and steam pressures in the range 6-20 atmospheres.

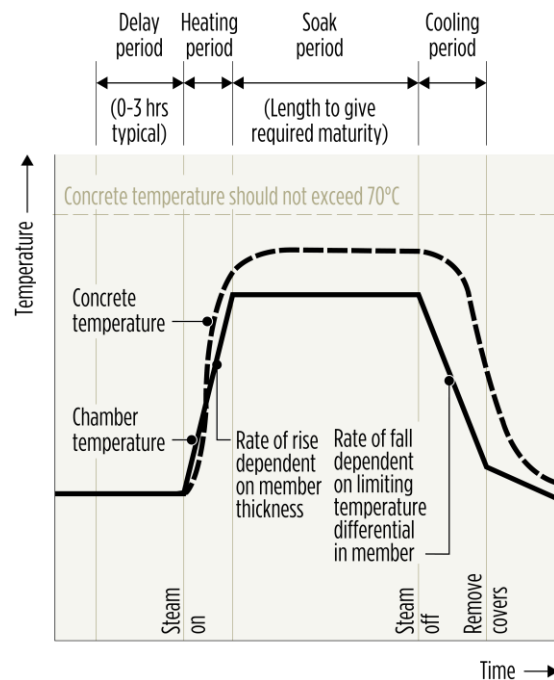

Figure 15.10 – Temperature/time Profile for a Typical Steam-curing Cycle and Concrete using GP or HE Cement

It is a specialised process requiring quite expensive equipment. Its use is therefore limited, although it is often employed in the manufacture of lightweight aerated concrete products to improve their strength and dimensional stability. **Figure 15.11** shows an autoclave for high-pressure steam curing of concrete blocks.



Figure 15.11 – Autoclave Equipment used to Harden and Cure Concrete Blocks

Autoclaving modifies the normal chemical reactions which occur when cement hydrates. Specifically, it causes the lime generated by hydrating cement to rapidly combine with any finely divided silica which may be present. Advantage is generally taken of this reaction by replacing up to 30-40% of the cement with

reactive silica material to improve both the strength and durability of the resulting product. More-detailed information on high-pressure steam curing may be obtained from the ACI Publication SP-32 [2].

5 SELECTING A METHOD OF CURING

Curing is one of the critical procedures which determines whether concrete will reach its potential strength and durability performance. While site conditions may often indicate that curing will be inconvenient (it is at best a messy procedure), consideration needs to be given to whether the cost savings resulting from failure to cure outweigh the real damage that may be done to the long-term strength and durability performance of the concrete by not curing properly. It is always feasible to choose a method of curing which will be both effective and economic and doing so should be a standard part of concrete placing practice.

The factors which affect the selection of a curing method include:

- The type of member to be cured, e.g. slab, column, wall etc.;
- The specified finish for the concrete member, e.g. Will the 'bond' of a subsequent coating be affected by the application of a curing compound;
- Whether the curing process will influence the appearance of the concrete;
- The construction schedule for the project, e.g. Will work need to continue in the area during the curing period;
- The cost and availability of materials, e.g. Is water available and how much will its sprays and supervision cost;
- Safety restrictions – e.g. Are there limitations which may mean some methods are not appropriate for health or safety reasons, e.g. Toxic fumes being generated in an enclosed space or slippery surfaces from plastic sheeting etc.;
- Weather conditions, exposure and location.

6 SUMMARY – CONSIDERATIONS WHEN SELECTING A CURING METHOD

General	Type of member	<ul style="list-style-type: none"> Is the member vertical or horizontal? (Some methods are affected or excluded by orientation, e.g. ponding.) Is the member thin or thick? (Thick sections such as large columns or mass concrete are mostly 'self-curing' but require temperature gradient at outer layers to be limited.) Is the element in-situ or precast? (Precast members are suited to low-pressure steam curing while some other products may benefit from autoclaving.)
	Environment	<ul style="list-style-type: none"> Does the location affect the availability or cost of some curing materials? (e.g. water in an arid region.) Is the weather likely to be hot or cold? (If the temperature is higher than about 30°C or less than 10°C special precautions need to be taken.) Is the site exposed to winds? (If so, special precautions may be required to prevent plastic shrinkage cracking; sprinkling methods may be affected; or extra care required when using plastic sheeting.)
Impermeable membrane curing	Retention of formwork	<ul style="list-style-type: none"> What is the effect on site operations and construction schedule? Is there likely to be cold weather? (This method allows easy addition of insulation.) Is uniform concrete colour specified? (If so, a constant stripping time will need to be maintained to avoid hydration-related colour changes.)
	Plastic sheeting	<ul style="list-style-type: none"> What is the effect on access and site operations? Is there any related safety consideration? (Plastic sheeting may be slippery, and therefore a hazard in horizontal applications.) Is there likely to be hot or cold weather? (Colour of sheeting should be selected to suit.) Is the situation such that the seal can be maintained with minimum risk of holing? Is uniform concrete colour specified? (If so, the sheeting must be kept clear of the surface to avoid hydration staining.)
	Curing compounds	<ul style="list-style-type: none"> What are the manufacturer's recommendations? (Both the rate of application and the timing are critical for effectiveness.) What is the concrete surface texture? (Coarse textures require higher application rates.) Can a uniform application be achieved in the particular situation? (Two applications at right-angles help. Sites exposed to wind create problems.) Is there likely to be hot or cold weather? (A suitably pigmented compound can help.) Are there to be applied finishes (paint, render, tiles etc.)? (Compounds can affect the 'bond' of applied finishes.) Is there a health consideration? (Solvents may be toxic, and their use in enclosed situations may be hazardous.)
Water curing	Ponding	<ul style="list-style-type: none"> What is the effect on access and site operations? Is suitable 'dam' material available? (A clay soil is the most suitable.) Is there likely to be hot weather? (Ponding is an efficient means of maintaining a uniform temperature on slabs.) Is concrete colour or appearance a consideration? ('Dam' materials, particularly clays, tend to stain.)
	Sprinkling	<ul style="list-style-type: none"> What is the effect on site operations? Is there an adequate water supply? What is effect of run-off? (Usually some form of drainage is required.) Will required volume/timing create any damage to the concrete surface? Can application be maintained continuously? (Intermittent wetting and drying can be deleterious.) Is site exposed to winds? (This makes continuous application very difficult.)
	Wet coverings	<ul style="list-style-type: none"> What is the effect on site operations? Can they effectively cover all surfaces? Is site exposed to wind? (Wet coverings are easier to keep in place than plastic sheeting.) Is concrete colour or appearance a consideration? (If so, sand should have low clay content; fabrics and water should contain no impurities.) In the case of sand, is supply or removal a problem? Can coverings be kept continuously moist? (Intermittent wetting and drying can be deleterious.)
Accelerated curing	Low-pressure steam curing	<ul style="list-style-type: none"> What is the effect on the production cycle? Will there be a cost benefit through greater productivity? (This usually results from quicker turnaround of formwork.) Is high early strength required? (Steam curing can help in achieving this.)
	Autoclaving	<ul style="list-style-type: none"> Will the process increase productivity? Will the process increase quality? Does the product require use of this process?

7 REFERENCES

- 1) *'Recommended Practice: Curing of Concrete (Z9)*', 2nd edition, Concrete Institute of Australia (1999)
- 2) *'Menzel Symposium on High Pressure Steam Curing'* American Concrete Institute Publication SP-32 (1972)

8 RELEVANT AUSTRALIAN STANDARDS

- 1) AS 3600 – *Concrete structures*
- 2) AS 3799 – *Liquid membrane-forming curing compounds for concrete*

CONTENTS

1. INTRODUCTION.....	2
2. FACTORS INFLUENCING THE APPEARANCE OF CONCRETE.....	2
2.1 GENERAL	2
2.2 FORMWORK.....	2
2.3 RELEASE AGENTS.....	5
2.4 CONCRETE MATERIALS AND MIX DESIGN.....	5
2.5 PLACING AND COMPACTING.....	5
2.6 CURING	6
2.7 TREATMENT OF TIE-BOLT HOLES	7
2.8 PROTECTION OF FINISHED WORK	7
3. THE SPECIFICATION OF SURFACE FINISHES.....	8
3.1 GENERAL	8
3.2 TEST PANELS.....	8
4 DEFECTS IN OFF-FORM CONCRETE...	9
5 REPAIRS AND REMEDIAL WORK.....	9
6 REFERENCES.....	17
7 RELEVANT AUSTRALIAN STANDARDS	17

The control of off-form concrete finishes – architectural concrete as it is sometimes known – involves careful planning of all aspects of the work including (a) the form faces and release agents to be employed, (b) the choice of concrete materials and mix proportions, and (c) the techniques used to place, compact and cure the concrete. This section will highlight the factors which influence off-form finishes and ways in which these factors can be controlled.

1. INTRODUCTION

This section deals with the control of surface finishes on off-form or 'architectural' concrete, i.e. concrete which is intended to have a predetermined appearance. Such finishes are produced by combining appropriate formwork with the use of good quality concrete and

correct placing, compaction and curing techniques.

Off-form finishes, to be successful, require very high standards of design, specification and construction. Above all, they require good communication between the architect and the contractor and a high degree of knowledge and skill on the part of the workforce. They are not necessarily 'easy' or 'cheap' to produce. This is not to suggest that good quality off-form finishes are beyond the skills of the average contractor but rather to emphasise that such finishes are the result of good planning and execution, i.e. they do not just happen.

2. FACTORS INFLUENCING THE APPEARANCE OF CONCRETE

2.1 GENERAL

Factors which influence the colour and texture of off-form finishes include:

- The nature of the formwork;
- The use of form liners;
- Release agents;
- Concrete materials and mix design;
- The use of pigments;
- Placing and compaction techniques;
- Curing; and
- The protection given to the finished work.

Since many of these factors are both interrelated and inter-reliant, they all need to be considered if visually good quality concrete surfaces are to be achieved.

2.2 FORMWORK

General – The quality of the formwork, and particularly the form faces have a major influence on the appearance of the concrete cast against it. Not only is the off-form finish a direct negative of the form face, it is also affected by formwork characteristics including:

- Stiffness;
- Absorbency; and
- Water-tightness.

If the formwork is not stiff, deflection and movement during concrete placing and compaction may contribute to a number of surface defects such as colour variation and/or a mottled appearance sometimes referred to as 'aggregate transparency'.

Variable absorbency of the form face will also result in colour variations and possibly even dark staining of the surface. The colour variation is caused by changes in the water/cement ratio of the concrete at the surface (**Figure 16.1**). While this is superficial in one sense, it may occur to a sufficient depth that subsequent tooling of the concrete may not remove the staining. The colour variations are usually most noticeable with changes of absorbency from one panel of timber formwork to the next. It should be noted that the absorbency of 'new' timber forms changes after a number of uses. In addition, the uniformity of the release agent coating can affect the absorbency of the form face.



Figure 16.1 – Hydration Staining and Colour Variation from Concrete placed in Layers

Loss of moisture and/or cement grout through formwork because of lack of watertightness leads to other surface problems, notably honeycombing (**Figure 16.2**). The joints between adjacent planks or formwork sheets should therefore be accurately made and rigidly held together and the joints between elements (e.g. between side wall and soffit formwork for beams) sealed with foamed

plastic strips or timber fillets fixed into the joints. Alternatively, a waterproof tape or joint sealant can be applied to the joints. It should be noted that the use of tapes will be reflected on the finished concrete surface.



Figure 16.2 – Honeycombing due to Inadequate Compaction or Grout/mortar Leakage

Formwork Design – All formwork should comply with the provisions of AS 3610. The formwork drawings should show the patterns of the form face (if any) and typical joints between formwork panels. Careful detailing of such joints is critical to the success of off-form finishes (**Figure 16.3**). For example, all control and construction joints on vertical surfaces should be indented or otherwise disguised (**Figure 16.4**).

Form Face Materials – A range of materials can be used to provide the form face against which concrete is cast. Each will give a characteristic texture/finish to the concrete surface. For a given situation (orientation of form face, exposure and desired appearance) some materials will be more suitable than others. For example, smooth faced materials such as plastic-coated plywood and fibreglass should not be used on surfaces that will be viewed close-up (i.e. from closer than three metres). It is difficult to ensure that such (smooth) surfaces are blemish-free and they are very difficult (if not impossible) to repair. However, these smooth materials can be used

where surfaces are visible only from greater distances. Similarly, a board-marked finish will tend to hold dirt on the surface and may harbour fungal growth in tropical climates and thus be unsuitable for external surfaces in certain geographic locations.



Figure 16.3 – Example of Carefully detailed Off-form Concrete

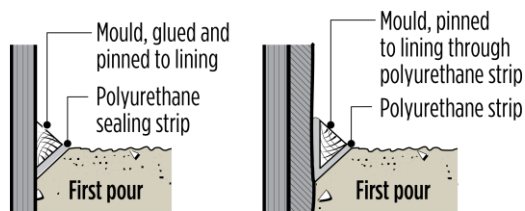

SMOOTH FORMS TEXTURED FORMS

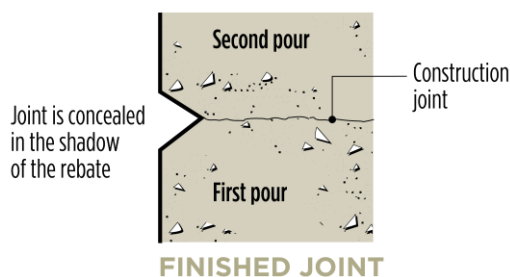

Figure 16.4 – Construction Joint on Vertical Surface

Traditionally, sawn timber has been used extensively as a form face or lining to produce 'board marked finishes'. Oregon boards are preferred – rough sawn or even lightly sand-blasted to bring out the grain. To avoid variable absorbency new boards should be sealed with several applications of a form oil and then

'pickled' by the application of a cement grout or slurry to the surface. The slurry is then allowed to dry before being brushed off. Sawn boards may be used to produce profiled finishes (Figure 16.5).

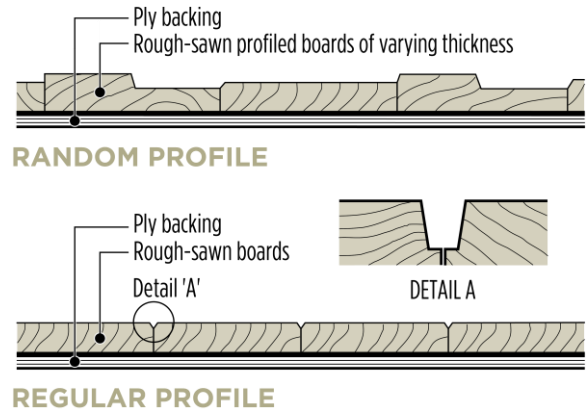

Figure 16.5 – Form Linings for Sawn-timber Finishes

Plastic coated plywood produces a smooth finish. However, as noted above, this formwork type is not recommended for surfaces that are to be viewed at close quarters. A light sanding of the face with fine sandpaper will help improve colour control as will 'pickling' the formwork surface before use.

As with sawn timber, a suitably detailed joint between plastic coated plywood panels is essential. It is almost impossible to disguise the joints between adjoining plywood sheets so, aesthetically, it is best to emphasise them. A rebate at the joint will normally be satisfactory, but in any event, sealing the joint between plywood sheets with a pre-formed foam strip is essential to prevent leakage of moisture and/or cement grout.

Fibreglass forms and form liners are often used for complex shapes and profiles that would be difficult or impossible to achieve by other means. They give a very smooth, mirror finish to the concrete (unless textured) and because of this they should only be used for surfaces that can be viewed from a distance. The joints between adjoining panels or shapes are difficult to disguise and as with other materials, they are best accentuated.

Other materials which have been used to achieve specific effects include (a) rubber and

other forms of plastic form liner, (b) hardboard sheets with the textured side exposed, (c) rope lightly secured to the formwork and then subsequently stripped from the concrete surface, as well as a variety of even more exotic processes. Experimentation and the construction of test panels with these materials is essential to confirm the anticipated texture and appearance as well as ensure satisfactory results for the member and surfaces involved.

2.3 RELEASE AGENTS

Both the type of release agent and the method of application can affect the quality and colour of a surface finish. Whilst it is beyond the scope of this Guide to discuss in detail the wide range of release agents available, it can be noted that chemical release agents are most likely to provide satisfactory results. Water-in-oil emulsions or neat oil with surfactants have also proved satisfactory. Test panels built prior to construction provide the best method for assessing the suitability of a release agent for the given application.

No matter what release agent is used, it is essential that it be applied uniformly and evenly over the form surface at the minimum rate consistent with full coverage. Surplus agent should be removed prior to concreting. Also, if colour control is specified, the same release agent should be used throughout the project.

2.4 CONCRETE MATERIALS AND MIX DESIGN

The requirements for concrete that will give consistent, high quality surface finishes are more demanding than those imposed by the simple strength/durability parameters of structural concrete.

These requirements may be expected to cover such matters as:

- The type of cement and supplementary cementitious materials and their source and relative proportions – to minimise colour variations due to cementitious materials throughout the project;
- The sand, and its source, again to ensure minimal colour variations;

- The coarse aggregates and especially the amount of flat, flaky or elongated particles to be permitted (a minimum practical limit is advisable because of the adverse effect such particles have on the textural quality of off-form finishes); and
- A minimum cement content – The mix design for concrete for high quality finishes will, typically, have a higher cement content and a lower water/cement ratio than may be necessary for the strength/durability requirements of the work. The concrete is sometimes less workable than plain structural concrete and, hence, may create issues with pumping. It may also require more intensive vibration to ensure full compaction.

On many jobs a suitable mix design will be agreed only after adequate field testing has been carried out, using the method of placement intended, and after test panels have been constructed. These may then serve as reference panels as the work proceeds. Sometimes, however, reference can be made to previous projects which are similar in finish and colour to that proposed, thereby reducing the amount of field testing required.

Once chosen, it is essential that the mix remains constant throughout the project. Materials should come from the same sources and their proportions should remain unchanged. The control of the water/cement ratio is particularly crucial. Mixes with a high sand content tend to give better colour control but may result in more blowholes in smooth finishes. Some compromise may therefore be necessary for best overall results. Over-sanded mixes should always be avoided.

Because of these special requirements, concrete for off-form finishes must always be specified as 'Special Class' concrete in terms of AS 1379.

2.5 PLACING AND COMPACTING

While good practice in placing and compacting concrete is always desirable, it is especially necessary to achieve high quality off-form finishes. Appropriate techniques are discussed

in Sections 12 and 13 of this Guide but specific attention is drawn to the following:

- The concrete should be placed at a continuous rate and consistently for each section of the work. In walls, the placing rate should be such that the lateral pressure assumed in the formwork design is not exceeded and the settlement in each layer is substantially complete before the next layer is placed (and no cold joints are formed);
- Placement should occur in uniform horizontal layers, with care being taken that the concrete is not moved horizontally or made to flow by the use of immersion vibrators;
- The concrete should be thoroughly compacted using the techniques described in Section 13 of this Guide. Special care should be taken to avoid touching the form face with immersion vibrators to avoid damaging it, and to avoid the formation of sand streaks on the surface of the concrete (**Figure 16.6**);
- To minimise the formation of blowholes in the top 0.5 m of walls and columns, the concrete should be rodded and/or re-vibrated prior to it stiffening.



Figure 16.6 – Surface Marking due to Immersion Vibrator touching Formwork

2.6 CURING

Curing of concrete is discussed in detail in Section 15. With off-form concrete some special precautions are required to ensure

work is not stained or discoloured during the curing process when colour control has been specified (**Figure 16.7**).



(a)



(b)

Figure 16.7 – Surface Appearance affected by Non-Uniform contact with (a) Formwork and (b) Cover

For example, there are special problems associated with the use of formwork to cure concrete. Generally speaking, to ensure adequate curing with formwork it is best to leave it in direct contact with the concrete, thereby preventing air movements which may cause the surface to dry out.

However, with off-form finishes it is often best to ease the form-face from the concrete at an early age to prevent scabbing (see **Table 16.2**). When this is done, it is essential to ensure that all faces are loosened otherwise uneven curing and colour variations may occur.

Other causes of discolouration are more obvious but should always be checked. For example, on vertical surfaces:

- Water curing can cause streakiness and non-uniform dis-colouration, and run-off onto completed work can cause similar problems. Iron salts or similar impurities in water may cause significant colour effects;
- Curing with hessian can cause problems. To overcome such issues it is important that (a) the hessian itself be thoroughly washed before use to ensure it does not stain the surface, and (b) that the hessian is kept uniformly wet to avoid uneven colouration of the cured surfaces;
- Curing with plastic sheets is a satisfactory method – provided the sheets are prevented from making contact with the concrete. Uneven contact can result in dark patches/mottling at the point of contact.

Plastic sheeting has the advantage that it helps protect finished work. A good method of preventing contact is the use of a light plastic or wire mesh stapled to a light timber frame secured to the wall through the tie-bolt holes. This may be left in place to protect the finished work as long as is necessary. Note that some colour variation may occur under the timber frame so its size should be kept to a minimum.

Curing compounds may also be employed to cure off-form concrete. As with other materials, preliminary trials are advisable to ensure there is no permanent staining from their use.

2.7 TREATMENT OF TIE-BOLT HOLES

The treatment of tie-bolt holes is especially important to the overall appearance of off-form concrete. A uniform bolt-hole pattern will enhance the appearance of the surface, while an uneven system will detract from the overall appearance (**Figure 16.8**).

Holes may be made good or filled with either plastic or concrete plugs fixed in position with epoxy mortar. Alternatively, they may be filled with a dry-packed mortar rammed into position.

In either case, the plug or filler should be recessed some 6-10 mm below the surface of the concrete finish.



Figure 16.8 – An Even Tie bolt-hole Arrangement will enhance the Overall Surface Appearance

Where possible, precast concrete plugs should be made with the same concrete as used in the element, to avoid colour contrasts.

If a dry-pack mortar mix is used it should consist of a 1:3 cement:sand mixture employing the cement and sand used in the original concrete – except that about 30-40% of the cement should be replaced with an Off-White cement to lighten the colour of the mortar. This compensates for the generally darker colour of small patches which in this case may be accentuated by the shadow effect of the recessed surface or plug.

To reduce shrinkage and the possibility of a more fluid material staining the surface of the finished work, the mortar should be an earth-damp mix which is compacted by ramming.

2.8 PROTECTION OF FINISHED WORK

Finished work should be protected from both accidental damage and staining.

Accidental damage can be caused in a number of ways, but normal care should suffice to minimise the occurrence of such issues. One problem not always guarded against, however, is the accidental splashing of finished work

either with fresh concrete or mortar or staining by grout lost from subsequent lifts.

Protection of finished work should therefore commence immediately after completion, i.e. as soon as the formwork has been stripped. As has been noted, one means of providing protection is to wrap the element in polythene film, taking care to ensure that it does not contact the fresh concrete surfaces. Surfaces which have been cured and allowed to dry out will not be harmed by wrapping them in polythene.

Work should also be protected from rust washed onto it from projecting (and unprotected) reinforcement; from formwork and screens on upper lifts; and from props or from other steel products used in subsequent lifts. Reinforcement may be protected by painting it with a cement slurry or wrapping it in plastic (though this is not recommended in areas of high humidity) (**Figure 16.9**). Other staining may be prevented by ensuring that materials used above completed work are clean and free from rust.



Figure 16.9 – Completed Work and Reinforcement protected by Wrapping

Another cause sometimes neglected is the staining of work at ground level by mud or soil 'splashed' onto it during rain or from passing vehicles. Protection of the concrete and good

site management are obvious precautions against these sources of staining.

3. THE SPECIFICATION OF SURFACE FINISHES

3.1 GENERAL

There are three broad approaches to the specification of surface finishes, viz:

- By performance;
- By method; and
- By a combination of performance and method.

Performance specifications may be based on the provisions of AS 3610 and Supplement 1 to that Standard. Section 3 of AS 3610 deals with surface finish and details five classes of finish by their visual characteristics and suitability for use in different situations (**Table 16.1**). Supplement 1 provides a series of photographs which may be used to evaluate the occurrence of blowholes in smooth finishes and a series of colour charts which may be used to evaluate colour consistency or control in finished work.

The Standard also provides details of the documentation required for each class of finish, tolerances for both linear and angular dimensions, and guidance on acceptable variations in colour.

Method specifications describe the method or technique which is to be used to achieve the required finish. Such specifications need to be complete and unambiguous if satisfactory results are to be obtained.

A combination of method and performance in the one specification is the least satisfactory system although it can be made to work if there is some objective standard (such as a test panel) against which to assess performance.

3.2 TEST PANELS

Test panels (**Figure 16.10**) arguably comprise the single most useful tool for determining compliance with a specification as they demonstrate the acceptability of the

combination of both materials and techniques. AS 3610 requires test panels to be provided for:

- Class 1 and Class 2 untreated surfaces;
- Colour control of surfaces; and
- Surface treatments.



Figure 16.10 – Test Panels should reflect all Aspects of the Proposed Structure

Test panels should be constructed on site using the materials, formwork and formwork details, release agents etc to be used in the actual work. This implies that they need to be of a size similar to that of the actual construction. Small sample panels, especially panels produced in a laboratory, will not properly reflect the ability of on-site construction techniques to produce the desired finish. Where surface treatments such as bush-hammering are to be applied a separate panel should be produced – and this panel may later be placed alongside the completed work for comparison.

Test panels may also be used to assess the acceptability of repair techniques should these be required at a later date.

4 DEFECTS IN OFF-FORM CONCRETE

The production of good quality off-form concrete depends, to a large extent, on recognising the factors which cause defects in it and how these effects might be minimised or even eliminated.

Tables 16.2 and 16.3 set out some of the more common (and some less common) defects which may be encountered in off-form concrete, and their probable causes. Once the causes have been identified, action can usually be taken to eliminate them.

5 REPAIRS AND REMEDIAL WORK

Repairs and remedial work to off-form concrete are undesirable because of the difficulty of achieving visually satisfactory results. AS 3610 gives the specifier the option of not allowing repairs to elements with Class 1 finishes. When necessary, the following precautions and procedures will assist in securing the best possible results:

- As far as is practicable, repairs should always be carried out by skilled and experienced crews;
- Repair techniques should be established early in the construction program, preferably using the pre-construction test panels, and a repair standard acceptable to all parties established;
- Repairs should then be undertaken at the earliest possible opportunity (preferably as soon as the form has been stripped) in order to ensure that the repair and the concrete are given the same curing and/or other treatments;
- Surfaces which are to be tooled and which exhibit significant defects such as blowholes or honeycombing must be patched prior to tooling. Reliance should not be placed on tooling to mask such defects. Appropriate time should be allowed for the patches to gain strength before tooling is commenced;
- Extreme care should be taken to establish a colour match between the

concrete surface and the patch. To achieve this, it will generally be necessary to substitute part of the original cement (perhaps as much as 40%) with Off-White cement. Patching with the original mix will almost inevitably result in a darker colour.

The choice of materials to be used and the repair technique will depend on the size and configuration of the defect. Blowholes may be filled with a colour-controlled patching mortar using a spatula. The surface should be lightly moistened prior to patching and an earth-damp mixture forced into the hole. Care should be taken not to smear the surface of the surrounding concrete with the patching mortar.

Repair techniques for honeycombing vary with the depth and the area involved. In shallow areas, all loose or partly adhering material should be removed, and the periphery of the area trimmed to a depth of 4-6 mm. The existing concrete should then be primed with a bonding agent and a suitable mortar packed into the hole and consolidated. The surface should then be finished to match the surrounding concrete, being careful not to overwork it.

Acrylic modified-Portland cement materials are available for patching work and, in general, appear to provide better performance than unmodified materials.

Where more extensive repairs and patching are required it may be possible to form up the area and to place concrete behind the forms. Forms used in this situation should have patterns and absorbency characteristics similar to the original formwork.

Bonding agents may be employed in such situations, but care should be taken that they are suitable for the application. (e.g. PVA-based bonding agents should not be used in locations where the concrete may become wet as they tend to re-emulsify in such conditions.)

Defects such as minor grout runs, form scabbing and some hydration staining can be remedied by rubbing the surface with a carborundum stone. Such treatments should be limited to small areas.

Acid etching, bleaching or similar treatments should be considered only as a last resort as the results may well exacerbate problems instead of curing them. Very careful consideration should always be given to whether repairs and remedial work will improve or worsen the appearance of the concrete. In certain cases the application of a photocatalytic coating may be required to achieve the desired finish.

Table 16.1 – Applicability of Surface Classes (from Table 3.2.1 in AS 3610.1)

	Class 1	Class 2	Class 3	Class 4	Class 5
Visual characteristics	Visual quality important. Highest quality attainable. Subject to close scrutiny. Best possible uniformity of appearance. Excellent quality of edge and joint details.	Visual quality important. Uniform quality and texture over large areas. Built to close tolerances. Consistently good quality of edge and joint details.	Visual quality important. Good visual quality when viewed as a whole.	Visual quality not significant. Appearance not important. Good general alignment.	Visual quality not significant. Alignment and appearance not important.
Suitable uses	Selected small elements contained in a single pour. Areas of special importance in limited quantities.	General external and internal facades intended to be viewed in detail and as a whole.	General external and internal facades intended to be viewed as a whole.	Surfaces concealed from general view. Surfaces to have thick applied finishes after preparation.	Totally concealed areas.
Surface treatment	Not applicable	Reference should be made to permitted tolerances prior to selection of applied material.	Reference should be made to permitted tolerances prior to selection of applied material.	Reference should be made to permitted tolerances prior to selection of applied material.	Not suitable
Situations where <u>not</u> to be used	For whole elevations or extended surface areas, trafficable slopes, soffits, formed tops of slopes except where means to dissipate air are employed, form liners. Is not applicable where treatment is to 100% of surface.	Formed tops of slopes except where means to dissipate air are employed.	No restriction	No restriction	No restriction
Colour control	May be specified. Refer to Clause 3.4.4 in AS 3610.1 for the limits of the best colour consistency that can be expected.	May be specified. Refer to Clause 3.4.4 in AS 3610.1 for the limits of the best colour consistency that can be expected.	May be specified. Refer to Clause 3.4.4 in AS 3610.1 for the limits of the best colour consistency that can be expected.	Excluded	Excluded
General	If these classes are required, they must be specified in the project documents.	If these classes are required, they must be specified in the project documents.	If these classes are not specified in the project documents, selection of appropriate class is by the visual characteristics and suitable uses set out above.	If these classes are not specified in the project documents, selection of appropriate class is by the visual characteristics and suitable uses set out above.	If these classes are not specified in the project documents, selection of appropriate class is by the visual characteristics and suitable uses set out above.

Table 16.2 – Physical Defects and their Causes

Defect	Description	Most probable causes
Honeycombing	Coarse stony surface with air voids, lacking in fines.	<ul style="list-style-type: none"> • Formwork: <ul style="list-style-type: none"> – Leaking joints. • Concrete mix: <ul style="list-style-type: none"> – Insufficient fines; – Workability too low. • Placing methods: <ul style="list-style-type: none"> – Segregation; – Inadequate compaction. • Design: <ul style="list-style-type: none"> – Highly congested reinforcement; – Section too narrow.
Blowholes	Individual cavities usually less than 12 mm diameter. Smaller cavities approximately hemispherical; larger cavities often expose coarse aggregate.	<ul style="list-style-type: none"> • Formwork: <ul style="list-style-type: none"> – Form face impermeable, with poor wetting characteristics; – Face inclined, face too flexible. • Release agent: <ul style="list-style-type: none"> – Neat oil without surfactant. • Concrete mix: <ul style="list-style-type: none"> – Too lean; – Sand too coarse; – Workability too low. • Placing methods: <ul style="list-style-type: none"> – Inadequate compaction; – Rate of placing too slow.
Mortar loss or grout loss or scouring	Sand textured areas devoid of cement. Usually associated with dark colour on adjoining surface. Irregular eroded areas and channels having exposed stone particles.	<ul style="list-style-type: none"> • Formwork: <ul style="list-style-type: none"> – Leaking at joints, tie holes, and the like. • Concrete mix: <ul style="list-style-type: none"> – Excessively wet; – Insufficient fines; – Too lean. • Placing methods: <ul style="list-style-type: none"> – Water in forms, excessive vibration of wet mix; – Low temperature.
Misalignment	Step, wave, bulge or other deviation from intended shape.	<ul style="list-style-type: none"> • Formwork: <ul style="list-style-type: none"> – Damaged, deformed under load; – Joints not securely butted. • Placing methods: <ul style="list-style-type: none"> – Too rapid or careless.
Plastic cracking	Short cracks, often varying in width across their length. On vertical faces, cracks are more often horizontal than vertical.	<ul style="list-style-type: none"> • Formwork: <ul style="list-style-type: none"> – Poor thermal insulation; – Form profiles or reinforcement which restrain settlement of the concrete. • Concrete mix: <ul style="list-style-type: none"> – High water/cement ratio; – Low sand content; – Excessive or insufficient bleeding of mix. • Ambient conditions: <ul style="list-style-type: none"> – Conditions leading to high evaporation of moisture from concrete.
Scaling, spalling or chipping, and form scabbing	Scaling is the local flaking or peeling away of a thin layer of mortar from the concrete. Spalling or chipping is the local removal of a thicker layer or edge of mortar. Form scabbing is the adhesion of portions of form surface, including sealant or barrier paint, to the concrete.	<ul style="list-style-type: none"> • Formwork: <ul style="list-style-type: none"> – Inadequate stripping taper; – Inadequate stiffness; – Movement of form lining due to change of concrete hydrostatic pressure with depth; – Keying of concrete into wood grain, saw kerfing / interstices in form surfaces; – Local weakness of form face. • Ambient conditions: <ul style="list-style-type: none"> – Frost action may cause spalling. • Stripping: <ul style="list-style-type: none"> – Too early stripping may cause scaling; – Too late stripping may cause scabbing.
Crazing	A random pattern of fine shallow cracks dividing the surface into a network of areas from about 5 mm to 75 mm across.	<ul style="list-style-type: none"> • Formwork: <ul style="list-style-type: none"> – Form face of low absorbency, smooth or polished. • Concrete mix: <ul style="list-style-type: none"> – A high water/cement ratio combined with cement-rich mix can be a cause. • Curing: <ul style="list-style-type: none"> – Inadequate.

Table 16.3 – Colour Variations and their Causes

NOTE: Some of the defects noted below may lessen or disappear with time, especially on surfaces exposed to weathering. It is not possible to state exactly what can be expected to happen on any particular surface. Some defects may appear sooner than others after stripping the forms.

Defect	Description	Most probable causes
Inherent colour variation	Variation in colour of the surface.	<ul style="list-style-type: none"> Materials: <ul style="list-style-type: none"> Change of cement brand; Change of source of fine and coarse aggregate; Variation in admixtures. Concrete mix: <ul style="list-style-type: none"> Variations in mixing procedure.
Aggregate transparency	Dark areas of size and shape similar to the coarse aggregate. Mottled appearance.	<ul style="list-style-type: none"> Formwork: <ul style="list-style-type: none"> Too flexible, causing a 'pumping' action during compaction. Concrete mix: <ul style="list-style-type: none"> Low sand content; Gap grading of sand. Placing methods: <ul style="list-style-type: none"> Excessive vibration.
Negative aggregate transparency	Light areas of size and shape similar to the coarse aggregate. Mottled appearance.	<ul style="list-style-type: none"> Materials: <ul style="list-style-type: none"> Aggregate dry or highly porous. Curing: <ul style="list-style-type: none"> Too rapid drying.
Hydration staining or discolouration (due to moisture movement within or from plastic concrete)	Variation in shape of the surface. Hydration staining and discolouration have a tendency to be severe at the top of a lift and at construction joints due to localised variations in water/cement ratio, incomplete compaction, and differential loss of moisture. Indentation of construction joints tends to disguise this discolouration by throwing the affected areas into shadow.	<ul style="list-style-type: none"> Formwork: <ul style="list-style-type: none"> Variable absorbency; Leaking through joints. Release agent: <ul style="list-style-type: none"> Uneven or inadequate application. Curing: <ul style="list-style-type: none"> Uneven.
Segregation discolouration, or sand runs (separation of fine particles due to bleeding at the surface of the form)	Variation in colour or shade, giving a flecked appearance.	<ul style="list-style-type: none"> Formwork: <ul style="list-style-type: none"> Low absorption; Water in bottom of forms. Concrete mix: <ul style="list-style-type: none"> Lean, high water/cement ratio; Unsuitably graded aggregate. Placing methods: <ul style="list-style-type: none"> Excessive vibration; Low temperature.
Dye discolouration or contamination	Discolouration foreign to the constituents of the mix.	<ul style="list-style-type: none"> Formwork: <ul style="list-style-type: none"> Stains, dyes, dirt on form face, timber stains, rust from reinforcement or metal form components. Release agent: <ul style="list-style-type: none"> Impure or improperly applied. Mix materials: <ul style="list-style-type: none"> Dirty; Contaminated by pyrites, sulfates, clay, organic matter or other impurities. Curing: <ul style="list-style-type: none"> Contaminated curing compounds; Contaminated curing water; Dirty covers.
Oil discolouration	Cream or brown discolouration. Sometimes showing sand or coarse aggregate.	<ul style="list-style-type: none"> Release agent: <ul style="list-style-type: none"> Excessive amount; Low viscosity; Impure; Applied too late or unevenly.
Lime bloom or efflorescence	White powder or bloom on surface.	<ul style="list-style-type: none"> Design: <ul style="list-style-type: none"> Permitting uneven washing by rain. Release agent: <ul style="list-style-type: none"> Type. Curing: <ul style="list-style-type: none"> Uneven conditions.
Retardation dusting	Matrix lacking in durability. Dusty surface which may weather to expose aggregate and which will erode freely under light abrasion at early ages – particularly in the period immediately following stripping of formwork.	<ul style="list-style-type: none"> Formwork: <ul style="list-style-type: none"> Retarder in or on form faces; Loss of contact between form face and hardening concrete (rapid drying). Release agent: <ul style="list-style-type: none"> Unsuitable; Excessive use of chemical release agent; Water soluble emulsion cream*; Unstable cream; Oil with excessive surfactant. Curing: <ul style="list-style-type: none"> Inadequate (very rapid drying).
Banding	Coarse texture corresponding to the width of the slipform, the bands often being of different colour.	<ul style="list-style-type: none"> Slipforming: <ul style="list-style-type: none"> Stop-start method of slipforming; Hardened concrete behind slipform cannot be finished off at the same age as the rest and has different hydration conditions; A more nearly continuous slipform motion causes less prominent banding.

NOTE: * 'Cream' refers to an emulsion of an oily material in water.

6 REFERENCES

- 1) CCAA, '*Guide to Off-Form Concrete Finishes*', CCAA T57 (2006)

7 RELEVANT AUSTRALIAN STANDARDS

- 1) AS 1012 – *Methods of testing concrete*
- 2) AS 1379 – *The specification and supply of concrete*
- 3) AS 3600 – *Concrete structures*
- 4) AS 3610.1 – *Formwork for concrete, Part 1: Specifications*



CONTENTS

1. OUTLINE.....	2
2. PREHARDENING CRACKS.....	2
2.1 GENERAL	2
3. CRACKS IN HARDENED CONCRETE. 4	
3.1 GENERAL	4
3.2 DRYING SHRINKAGE CRACKS ...	5
3.3 THERMAL MOVEMENT CRACKS.	6
3.4 STRUCTURAL CRACKS	6
4. JOINTS	7
4.1 GENERAL	7
4.2 CONSTRUCTION JOINTS.....	7
4.3 CONTRACTION JOINTS	9
4.4 EXPANSION JOINTS	10
4.5 ISOLATION JOINTS	11
4.6 WATERTIGHT JOINTS.....	11
5. CRACK REPAIR	12
5.1 GENERAL	12
6. REFERENCES	15

1. OUTLINE

Cracks form in concrete construction for a variety of reasons and at different times – sometimes before the concrete has hardened, sometimes long after. This Section summarises information on the various types of cracking which may be encountered, the principal causes of cracking and methods used to minimise or prevent cracking. Information is also provided on repair techniques which may be used if cracking occurs.

Cracks may occur in concrete construction for a variety of reasons. For example, drying shrinkage occurs when hardened concrete loses moisture. Being a brittle material with a low tensile strength, if this shrinkage is restrained the concrete is liable to crack as it shrinks, unless appropriate measures are taken to control this (such as the provision of control joints).

Cracks may occur due to settlement of the concrete, movement of the formwork before the concrete member is able to sustain its own weight, or due to changes in the temperature of the concrete and the resulting thermally induced movement.

Appropriate measures will at least minimise, if not prevent entirely, these forms of cracking.

2. PREHARDENING CRACKS

2.1 GENERAL

Cracks which form before concrete has fully hardened (e.g. in less than eight hours) are known as pre-hardening cracks. There are three main types:

- Plastic shrinkage cracks;
- Plastic settlement cracks;
- Cracks caused by formwork movement.

All occur as a result of construction conditions and practices although, obviously, faulty formwork design may lead to its movement and/or failure. Pre-hardening cracks are usually preventable by the adoption of good construction procedures.

Plastic Shrinkage Cracks

Plastic shrinkage cracks are formed in the surface of the concrete prior to the concrete setting and hardening. It is common that these cracks are barely visible until after the concrete has hardened and the surface has started to dry. They are due to the too-rapid loss of moisture from the surface of the concrete and generally result from concrete placing and finishing processes during hot, dry or windy conditions.

Plastic shrinkage cracks normally form without any regular pattern and may range from 25 mm to 2 m in length. These cracks vary from a hairline to perhaps 3 mm in width. Since they occur most often in hot weather, they are discussed in Section 18 '*Hot- and Cold-Weather Concreting*' in this Guide, to which reference should be made for further information and for guidance on procedures to prevent their occurrence.

Plastic Settlement Cracks

Most concrete, after it is placed, bleeds (i.e. water rises to the surface as the solid particles settle). The bleed water evaporates at the exposed surface and there is a loss of total concrete volume (i.e. the concrete has 'settled'). If there is no restraint, the net result is simply a very slight lowering of the surface level of the concrete. However, if there is some restraint near the surface such as a reinforcing bar, which restrains part of the concrete from settling while the concrete on either side continues to drop, there is potential for a crack to form over the restraining element (Figure 17.1).

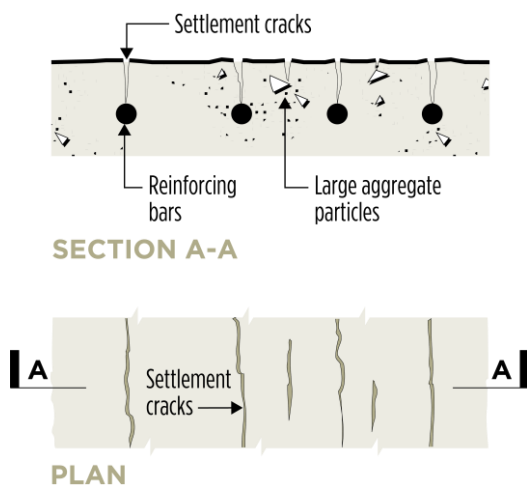

Figure 17.1 – Settlement Cracking

Differential amounts of settlement may also occur where there is a change in the depth of a section, such as at a beam/slab junction (Figure 17.2). Settlement cracks tend to follow a regular pattern replicating the lines of restraint, usually the reinforcement, or a change in section. Generally, the cracks are not deep but, because they tend to follow and penetrate down to the reinforcement, they may reduce the durability of a structure.

Factors which may contribute to plastic settlement include:

- Rate of bleeding and total bleeding;
- The time over which settlement can take place, e.g. time before the concrete begins to set;
- The depth of reinforcement relative to total thickness of the section;

- The ratio of the depth of reinforcement from the concrete surface (i.e. concrete cover) to size of bar;
- The constituents of the mix;
- The concrete slump.

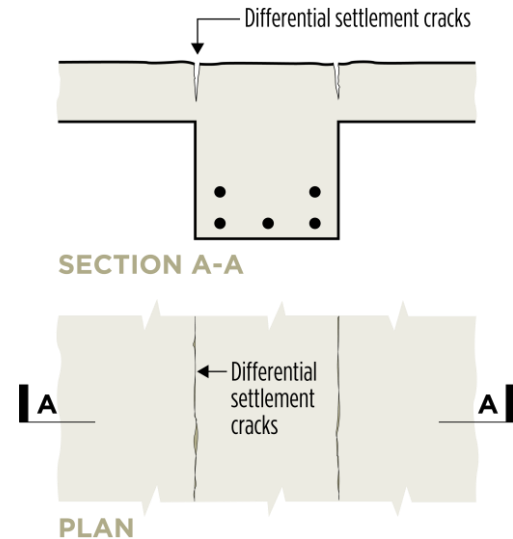

Figure 17.2 – Differential Settlement Cracking

Prevention of Plastic Settlement Cracking

Plastic settlement cracks may be prevented, or rather reduced, by re-vibrating the concrete after bleeding and settlement is virtually complete and the concrete has begun to stiffen. Re-vibration closes the cracks and enhances the surface finish and other properties of the concrete. Careful timing is essential to ensure that the concrete liquefies under the action of the vibrator and that the cracks disappear. Applying vibration before the concrete has begun to stiffen may allow the cracks to reopen. Applying it too late may damage the bond with reinforcement or reduce its ultimate strength (see Sections 13 and 14, 'Compaction' and 'Finishing Concrete Flatwork', in this Guide).

Other procedures which may help reduce plastic settlement cracking include:

- Using lower slump mixes;
- Using more cohesive mixes;
- Using an air entraining agent to improve cohesiveness and reduce bleeding;
- Increasing cover to the top reinforcement bars.

Where there is a significant change in section, the method of placing may be adjusted to compensate for the different amounts of settlement. If the deep section is poured first to the underside of the shallow section, this concrete can be allowed to settle before the rest of the concrete is placed. However, the top layer must be well vibrated into the bottom layer.

Avoiding the use of retarders is sometimes suggested as a way of speeding up concrete setting and so reducing bleeding and plastic settlement cracking. In the case of hot-weather concreting, the advantages of retarders generally outweigh the disadvantages.

Cracks Caused by Formwork Movement

If there is movement of the formwork, whether deliberate or unintentional, after the concrete has started to stiffen but before it has gained enough strength to support its own weight, cracks may form.

Such cracks have no set pattern. To avoid cracking from this cause, formwork must be:

- Sufficiently strong and rigid to support the weight of the concrete without excessive deflections; and
- Left in place until the concrete has gained sufficient strength to support itself.

Some guides for the stripping time of formwork assume that Type GP cement is being used. Concretes incorporating supplementary cementitious materials (such as fly ash and ground slag) may take longer to gain strength and allowance should be made for this.

3. CRACKS IN HARDENED CONCRETE

3.1 GENERAL

Cracks occur in hardened concrete for three principal reasons, namely:

- Volume changes in the concrete;
- Chemical reactions within the body of the concrete that produce expansive reaction products that may cause cracking of the concrete;

- Cracking as a result of designed loading on the structure or overloading (structural cracking).

Volumetric movement in concrete cannot be prevented. It occurs whenever concrete gains or loses moisture (drying shrinkage) or whenever its temperature changes (thermal movement). If such movements are excessive, or if adequate measures have not been taken to control their effects, the concrete will crack.

Chemical reactions within the body of the concrete, which can cause it to expand and crack, include reinforcement corrosion and sulfate attack (see Section 25 '*Properties of Concrete*'), and alkali aggregate reaction (see Section 3 '*Aggregates*' in this Guide). Provided adequate care is taken in the selection of materials and good quality concrete is properly placed, compacted and cured, these reactions should not occur except in extreme environmental conditions.

Crazing on Concrete Surfaces

The word 'Crazing' describes the very fine (spider web-like) cracks which appear on the surface of concrete after it has been exposed to the atmosphere for some time. It can occur on both trowelled and formed surfaces but is more noticeable on trowelled surfaces, particularly when the surface has been wetted and allowed to dry out. It occurs when a thin, paste-rich layer on the concrete surface expands and shrinks during alternate cycles of wetting and drying, or as it carbonates and shrinks during long exposure to the air. The shrinkage and expansion in the thin surface layer are restrained by the mass of the concrete below it – resulting in craze cracking.

The use of cement-rich mixes on the surface of the concrete, adding dry cement powder to the surface during finishing exacerbates the problem, as does overworking (bringing excess paste to the surface) or trowelling bleed water back into the surface.

On formed surfaces, crazing tends to occur on smooth faces cast against low-permeability form-face materials.

Prevention of Cracking

To avoid 'crazing' on trowelled surfaces:

- Avoid very wet mixes;
- Do not use dry cement powders on the concrete surface during finishing;
- Do not overwork the concrete surface during finishing;
- Do not attempt finishing while bleed water is present;
- Do not steel trowel the concrete surface during finishing until the water sheen has gone and setting has started;
- Commence continuous curing promptly;
- Do not subject the surface to wetting and drying cycles.

On formed surfaces, very wet and over-rich mixes should be avoided, and curing should be continuous. The concrete should not be subjected to wetting and drying cycles during curing.

3.2 DRYING SHRINKAGE CRACKS

Hardened concrete shrinks or reduces in volume as it loses moisture due to:

- The hydration of the cement;
- Evaporation.

The shrinkage caused by moisture loss is not a problem if the concrete is completely free to move. However, if it is restrained from movement in any way, then tensile stress will develop. If that stress exceeds the ability of the concrete to carry it, the concrete will crack.

A number of factors influence the drying shrinkage of concrete, in particular the total water content. Other factors include:

- The content, size and physical properties of the concrete aggregate used in the mix;
- The relative humidity of the surrounding air;
- Admixtures used in the concrete, especially any containing calcium chloride;
- The curing methods used on the exposed surfaces of the concrete after finishing.

The cement content of concrete influences drying shrinkage to the extent that it may influence the amount of water used in a mix at a particular W/C ratio.

In order to reduce the total shrinkage of concrete:

- The water content of the mix should be minimised (consistent with the requirement for placing and finishing);
- The amount of fine material used in the mix should be minimised;
- The highest possible coarse aggregate content should be used in the mix design (consistent with the requirement for placing and finishing);
- The largest possible maximum aggregate size should be in the mix design (consistent with the requirement for placing and finishing);
- Good curing practices should be adopted.

Simply reducing the drying shrinkage of a concrete will not necessarily reduce cracking since it is also influenced by the restraint, detailing, geometry, construction practice etc.

Preventing Cracking due to Drying Shrinkage

The prevention of uncontrolled cracking due to drying shrinkage starts with the designer. Appropriate design and detailing are essential. Attention should be given to the following:

- Adequate reinforcement to distribute the tensile stress caused by drying shrinkage must be provided. This is particularly important in floors, slabs-on-ground, and similar applications where reinforcement may not be required for load-carrying or structural reasons;
- The provision, location and detailing of joints to isolate restraints and permit movement between discrete parts of the construction.

Construction practice is also important for it should ensure:

- That the concrete is properly placed, compacted and cured in order to

minimise the magnitude of drying shrinkage;

- That the designer's details (reinforcement and joint locations) are correctly put in place;
- The removal of restraint by the formwork.

3.3 THERMAL MOVEMENT CRACKS

Thermal movement occurs when the temperature of concrete changes, due either to environmental changes or to the heat generated when the cement/binder hydrates.

Thermal movements due to changes in the ambient temperature are normally less of a problem in concrete structures, provided an adequate number of control or movement joints provided in slabs or long straight walls and in similar members are included; and provided isolation joints are arranged at restraints which might prevent the concrete from contracting or expanding.

Hardened concrete expands as temperature rises and shrinks as it cools. The coefficient of thermal expansion for concrete used in AS 3600 for the purposes of design is $10 \times 10^{-6}/^{\circ}\text{C}$. Concrete that has a thicker section (typically over 500 mm minimum thickness of the concrete structure) is more susceptible to retaining heat caused by cement hydration. When this is combined with mixes containing higher cement content it can lead to a rise in temperature of up to 50°C from the initial plastic concrete temperature. Using the coefficient of thermal expansion for concrete noted above it can be estimated that the concrete in this example may go through an expansion during heating and contraction during the cooling phase of up to 500 micro-strain. In this case the early thermal movement may exceed the drying shrinkage movement over the life of the structure. Thinner structural elements and those using mixes with lower cement content are less affected by this form of movement.

Preventing Cracking due to Thermal Movement

The prevention of uncontrolled cracking due to thermal movement requires careful design of structural elements. Consideration should be

given to the design of reinforcement, joints (where feasible) and the concrete mix being used.

3.4 STRUCTURAL CRACKS

When concrete structural designers are following the design principles set out in AS 3600, they will need to take account of the impacts of concrete structural cracking along with the effects of temperature movements and shrinkage. When a structural member is loaded in service it may deflect under load and zones of tensile stress will form in the member. The designer will need to consider the proportion of steel required to control the stresses resulting from all of these factors. In general, crack width is controlled to an acceptable level that meets the following needs:

- Aesthetics or the appearance of the cracks in the particular location of the member being assessed;
- Durability of the concrete and ability to maintain the service life of the structure in the service environment.

In a benign environment the visibility of cracks at the viewing distance may be of more concern and larger crack widths may be acceptable.

In environments with higher exposure classifications such as AS 3600 classifications B1, B2, C1 and C2, the design crack width will require careful consideration and typically may be limited to a maximum of 0.1 mm to 0.2 mm.

The types of members where structural cracking from design loads or overloading is a significant issue will most likely be:

- Beams;
- Suspended slabs;
- Columns (where tensile zones exist).

In members such as slabs on ground, walls or some foundations, it is probable that the effects of restraint combined with shrinkage and temperature movements will need to be designed for.

Prevention of Structural Cracking

Structural cracking control is largely in the hands of the structural designer, the construction contractor and the structure owner.

The design of concrete to avoid excessive cracking under load is controlled largely by employing adequate reinforcement in the tensile zones of structural members. The factors to achieve this control include reinforcement ratios, maximum design stress in reinforcement, location of reinforcement and reinforcement bar sizes to be used. Details of these controls in design are contained in AS 3600.

The construction contractor must ensure that the details of reinforcement positioning, quantity and bar sizes are carried out in accordance with the design. Concrete must be properly placed, compacted and cured to ensure that it achieves its potential strength as per the design. Formwork retention and propping of suspended beams and slabs must occur for sufficient time to ensure that the concrete reaches sufficient strength to avoid overloading.

The structure's owner must take steps to ensure that the design loadings on the structure are known and not allowed to be exceeded.

4. JOINTS

4.1 GENERAL

Joints in concrete construction may serve a number of purposes but are of two basic types:

- Those that do not allow relative movement of the concrete on either side of the joint; and
- Those that allow such movement.

The former – construction joints – aim to bond the concrete on either side of the joint in such a way that it acts monolithically. The latter type allows movement of the concrete in a controlled manner.

Joints that allow movement include:

- Contraction joints – which allow for shrinkage movements;
- Expansion joints – which allow movement towards or away from the joint, but prevent movement in other directions;
- Isolation joints – which allow two abutting concrete faces to move freely relative to one another.

4.2 CONSTRUCTION JOINTS

Construction joints are concrete-to-concrete joints made in such a manner that the two faces are held together to prevent any relative movement across the joint. They are required whenever there is a break in concreting operations which is sufficiently long that the concrete which has been placed has hardened before fresh concrete can be placed against that face. Such stoppages (and joints) may be planned or unplanned.

While unscheduled interruptions to the placing of concrete are to be avoided as far as is possible, they do occur. Some interruptions can, however, be foreseen (e.g. at the end of the day) and should be planned carefully to ensure that the joint is placed in a position where it will have the least effect, either structurally or visually. Ideally, such interruptions should be planned to coincide with an expansion, contraction or isolation joint. This will minimise the number of joints and also the possibility of faulty construction joints.

Faulty construction joints weaken the structure and may allow moisture to penetrate into or through the joint and possibly (a) cause reinforcement to corrode, and/or (b) result in staining of the concrete surfaces.

Location of Construction Joints

The concrete structure's designer should nominate/approve the location of construction joints in structural members because they usually result in a plane of weakness. Thus, they are normally located where shear forces in the member are low (e.g. in the middle third of beams and slabs).

Suitable locations for construction joints should be shown on the design drawings and should

not be changed without the approval of the designer. Nor should additional joints be made without the designer's approval.

AS 3600 requires that, unless otherwise specified, construction joints must be made at the soffits of slabs or beams and their supporting walls or columns (**Figure 17.3**). As a general rule, horizontal joints are never allowed in slabs or are vertical joints in beams or slabs near their supports because shear stresses at these locations may be high.

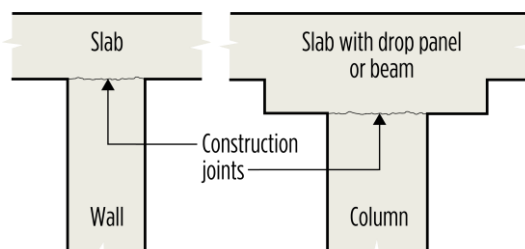

Figure 17.3 – Construction Joints between Horizontal and Vertical Elements

Vertical Construction Joints

When a construction joint has to be made in a beam or slab, a stop-end or bulkhead should be used to ensure that a vertical joint is properly formed (**Figure 17.4**). If the concrete is left free it will subside at an angle and be impossible to compact. The result will be a weak joint.

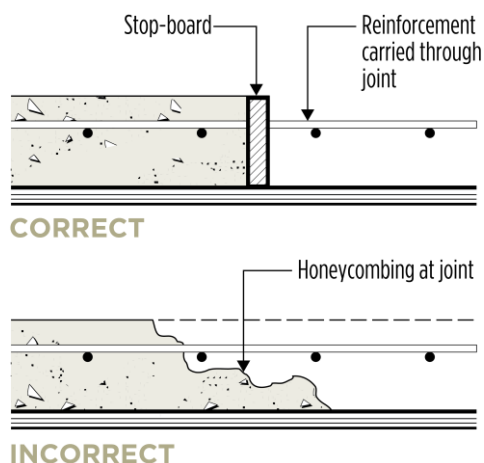
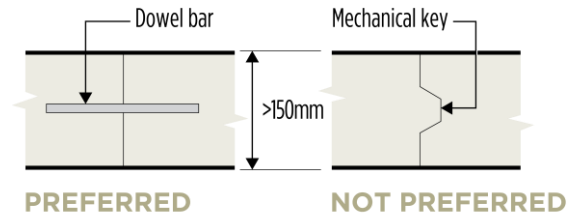

Figure 17.4 – Construction Joint in a Slab

To assist the transfer of loads across vertical joints, dowels or keyways are advisable in slabs over 150 mm in depth (**Figure 17.5**).

Reinforcement should not be cut at construction joints so that, where necessary, stop-ends must be slotted or fitted in sections so that they permit reinforcement to pass through them without allowing mortar leakage.



NOTE: Slab reinforcement not shown, but should be carried through the joint

Figure 17.5 – Load Transfer across Construction Joints in Slabs over 150 mm Thick

The treatment to be given the partially hardened concrete before fresh concrete is placed against it will depend on its age. If it is less than four hours old, it is recommended to brush it with a wire brush. This roughens the surface and removes any weak material. Any residue from this treatment should be removed.

If the surface is more than four hours old at the time the fresh concrete is placed, water-blasting or other means may have to be used to expose the coarse aggregate of the concrete. The exposed surface should then be cleaned and dampened before fresh concrete is placed against it. A good mechanical keying of the coarse aggregates is important to an effective vertical construction joint shear restraint. Reliance on grouts or other 'adhesives' to provide bond is not recommended.

Horizontal Construction Joints

When fresh concrete settles or is compacted mechanically, a layer of laitance – watery grout – tends to form on the top surface. If this is allowed to harden, it forms a plane of weakness. Whenever possible, therefore, laitance should be removed as early as practicable from the surface of concrete against which a horizontal joint is to be formed. When the joint surface is not more than four hours old, this is relatively easy. Surfaces may be simply wire-brushed to expose sound concrete and all loose material removed. Fresh concrete should then be thoroughly compacted against the old surface.

Where the joint is being made against concrete more than a few hours old, additional treatment may be necessary, depending on the time that has elapsed.

Wire-brushing, the use of high-pressure water jets and even sandblasting are all methods which have been employed to expose sound concrete at the surface of a proposed horizontal construction joint. The exposed surface should then be cleaned of all loose material and free-standing water, dampened if necessary and fresh concrete compacted against it. Lengthy delays between clean-up and concreting may require the surface to be cleaned and dampened again before concreting operations are resumed.

Where a clean neat line is needed (e.g. in an exposed or rendered wall) typical formwork details are shown in **Figure 17.6**.

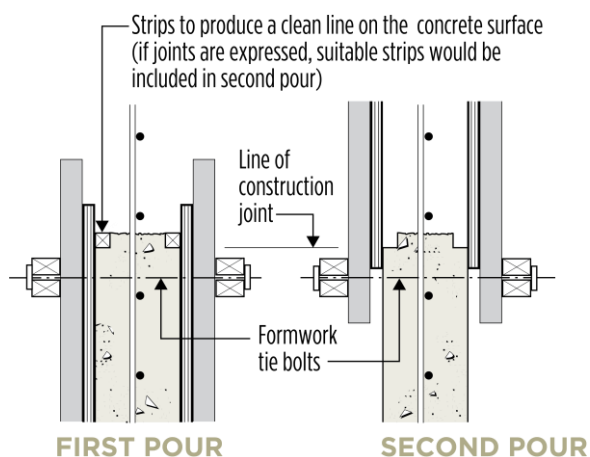

Figure 17.6 – Horizontal Construction Joint in a Wall when a Clean, Neat Line is needed

4.3 CONTRACTION JOINTS

A contraction joint is one in which the two concrete surfaces are free to move away from one another as a result of shrinkage or thermal movement. Relative movement in the plane of the joint is prevented.

As concrete hardens and dries out, it shrinks. Unless this shrinkage is unrestrained, it creates tensile stresses in the concrete which may cause it to suffer from un-controlled cracking.

While reinforcement will resist these tensile stresses and help prevent the formation of large cracks, it does not completely prevent

cracking. It merely ensures that the cracks, if they occur, are more closely spaced and of smaller width. In properly designed reinforced concrete these cracks will not be obvious or of concern when seen from normal viewing distances.

Unreinforced concrete on the other hand, will tend to develop somewhat larger cracks at more irregular intervals, wherever the tensile strength of the concrete is exceeded by the shrinkage stresses. To prevent such cracks, contraction joints must be installed at appropriate intervals. It may also be advisable to install contraction joints in reinforced concrete rather than relying solely on reinforcement to control shrinkage stresses.

Contraction joints may also be required in mass concrete or very large members to allow for the shrinkage or reduction in volume which occurs as concrete cools or loses temperature after it has been placed.

Location of Contraction Joints

The location of contraction joints is a matter for the designer or supervising engineer to decide. For example – their location will often be defined on the drawings for pavements, industrial floors and similar applications. In other cases, they will be in a regular pattern or be an integral part of the architectural features.

Generally, they will be situated where the greatest concentration of tensile stresses resulting from shrinkage are to be expected, namely:

- At abrupt changes of cross-section;
- In long walls, slabs.

Contraction joints are most common in large areas of concrete pavement where they are used to divide the concrete into bays. Ideally, these should be approximately square. They may also be necessary in long walls, particularly where an unplanned crack would be undesirable.

Contraction joints form a convenient point at which to stop concrete work at the end of the day. This is an optimal practice to avoid having construction joints in the middle of a bay, which may compromise its load-carrying capacity and durability.

Construction of Contraction Joints

Contraction joints are formed by creating a vertical plane of weakness in the slab or wall. Movement is allowed at this point to accommodate changes due to shrinkage. On the other hand, it is usually necessary to prevent movement in other directions, i.e. in directions parallel to the plane of the joint (**Figure 17.7**). These twin requirements have the following consequences:

- The bond between abutting concrete surfaces in the joint must be broken;
- Reinforcement is terminated on both sides of the joint;
- Dowel bars, if used, must be un-bonded on one side of the joint.

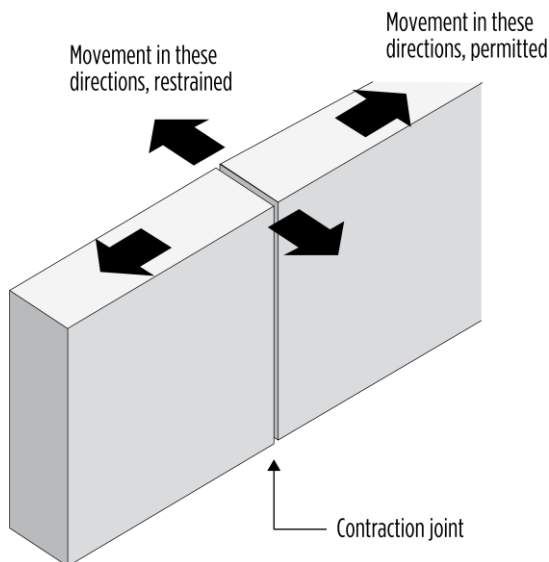

Figure 17.7 – Vertical Contraction Joint

Control Joints

A control joint is a form of contraction joint which is formed by building a plane of weakness into either a vertical or horizontal member. As the concrete shrinks, tensile stress is concentrated on this plane causing the concrete to crack there rather than elsewhere.

Normally, mechanical interlock across the two faces of the joint is expected to prevent other movement in the joint.

Control joints are a relatively simple alternative to a fully formed contraction joint. They are placed wherever a formed joint would have been placed and are most widely used in

unreinforced slabs and pavements. Joint spacing in unreinforced slabs ranges from 1 m for thin pedestrian pathways, to approximately 6 m for road pavements.

Control joints can be made at any one of three stages during construction:

- A pre-moulded strip may be inserted into the concrete as it is being placed, to create a plane of weakness. Metal strips inserted into terrazzo or preformed plastic strips inserted into concrete pavements to form the centre line of the pavement are examples;
- A joint can be formed in the surface of the concrete with a suitable jointing or grooving tool. Upon hardening, the concrete cracks at this point, creating a joint.

(NOTE: The resultant joint must be at least 25% of the depth of the slab to be effective.);

- After the concrete has hardened sufficiently to prevent raveling of the edges, a sawn joint may be formed. The joint should be made as early as possible and prior to drying shrinkage starting to occur. Delay can result in unplanned cracking of the pavement. The sawn joint is then filled with a joint sealant to prevent dirt and other debris entering it (**Figure 17.8**) as unsealed joints tend to fill with dirt and become ineffective.

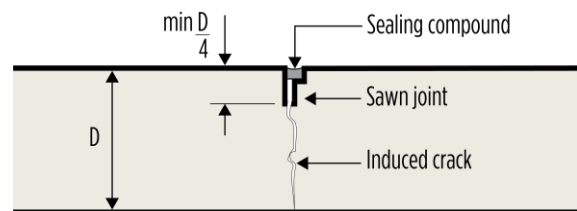

Figure 17.8 – Sawn Joint in Concrete Pavement

4.4 EXPANSION JOINTS

Expansion joints are formed to permit concrete elements to expand as the temperature of the concrete increases. Although the thermal expansion of concrete is relatively low, it is sufficient to cause distress under Australian climatic conditions where the surface temperature of a concrete pavement might

increase by as much as 40-50°C during a hot summer's day.

There is considerable divergence of opinion on the necessity for expansion joints in concrete structures. Most often, such structures have contraction or control joints, which, if properly protected from becoming filled with dirt or other debris, will accommodate the thermal expansion of concrete under most conditions. On the other hand, expansion joints are normally too widely spaced to function as contraction joints.

In the final analysis, it is the designer who must give careful consideration to the need for expansion joints in a particular building or structure. Considerations which might influence that decision are:

- Whether the structure will contain contraction or control joints. (Some reinforced concrete structures incorporate reinforcement to control shrinkage cracking and omit contraction or control joints);
- Whether the structure is likely to be subjected to a considerable range of temperature;
- Whether there are fixed restraints which are likely to cause damage (or be damaged) should thermal expansion take place. A pavement abutting a bridge deck is a good example;
- Whether the structure is likely to be subjected to a significant temperature rise before it has dried out and drying shrinkage has occurred.

Construction of Expansion Joints

Since expansion joints are designed to permit movement in only one plane, i.e. at right angles to the plane of the joint, some provision must be made to prevent movement in the plane of the joint. This may take the form of a dowel or dowels (**Figure 17.9**).

Keyed joints are not usually satisfactory because of the difficulty of sealing and maintaining them. Those which become packed with dirt or other debris cease to function and may result in damage to the building or structure.

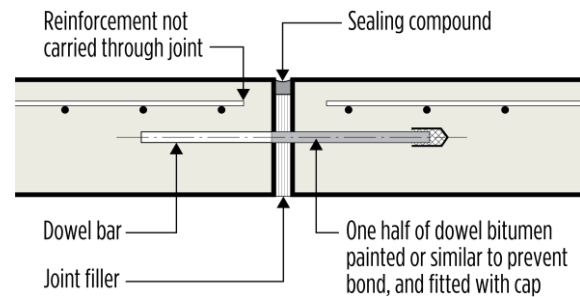

Figure 17.9 – Dowelled Expansion Joint

4.5 ISOLATION JOINTS

An isolation joint is one that allows complete freedom of movement on either side of the joint – as they have to accommodate both vertical and horizontal movements.

A common example of this is where a slab on ground abuts another structure which it is not connected to and must allow for expansion and shrinkage of the slab without damaging either the slab or the structure it butts up to.

Location of Isolation Joints

Isolation joints are located in buildings and other structures at points where differential movement is likely to occur. Where such movements include both vertical and horizontal components, an isolation joint is indicated. They are used to isolate:

- Machinery footings from the rest of the building;
- One part of a building from another, e.g. basement slabs from columns by boxing out the column support (**Figure 17.10**), or a floor from a wall (**Figure 17.11**);
- Delicate equipment from moving or vibrating floors.

4.6 WATERTIGHT JOINTS

In structures like reservoirs, water tanks, sludge tanks and other liquid-retaining structures, watertightness is a very important consideration. In consequence, both vertical joints and horizontal joints require special attention to ensure that they remain watertight in service.

Vertical construction joints require sealing as they tend to open up as the concrete shrinks.

Similarly, contraction joints and expansion joints, which are designed to move, require special treatment.

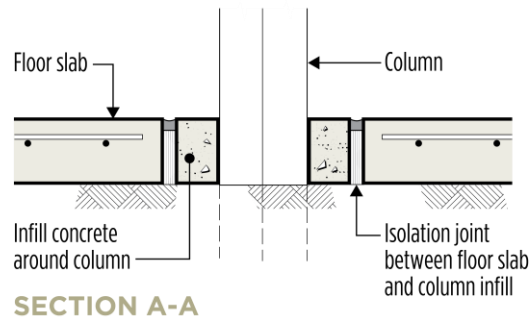

SECTION A-A

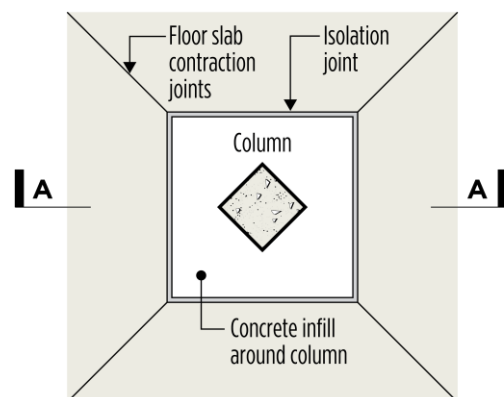

PLAN

Figure 17.10 – Isolation Joints around Column

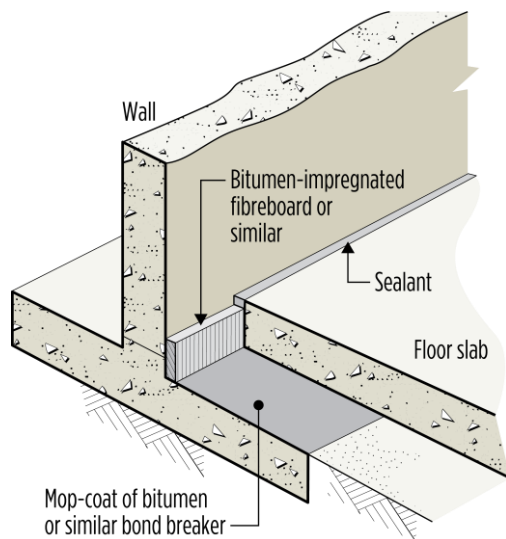

Figure 17.11 – Isolation Joint between Slab and Wall

The most common solution in all three cases is the insertion of a water-stop in the joint. This may be one of two types:

- A metal water-stop – normally a strip of copper sheeting placed in the joint so that it extends equal distances on either side;
- A flexible water-stop – normally a rubber or PVC moulded shape. It may have the shape of a dumb-bell or have a central bulb (Figure 17.12).

WATER TANK WALL CROSS SECTION AT JOINT

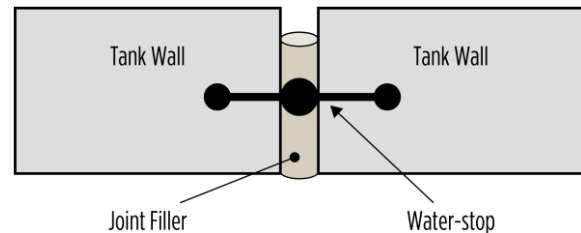

Figure 17.12 – Typical Rubber Water Stop with Central Bulb

Where specific sealing of an expansion joint is required, the water-stop must be capable of movement itself. Copper strips with a central crimp or flexible stops with a central bulb meet this requirement. Isolation joints may need similar treatment. Horizontal joints, in walls for example, will not normally require a water-stop since, if properly prepared, there is less tendency for them to open up.

5. CRACK REPAIR

5.1 GENERAL

When repairs to a crack are being considered, the following factors should be taken into account:

- Whether the crack is dormant (i.e. it is unlikely to extend or open further) or whether it is live (i.e. it is likely to be subject to further movement);
- The width and depth of the crack;
- Whether or not sealing against pressure is required, and, if so, from which side of the crack will the pressure be exerted;
- Whether or not appearance is a factor.

Above all, it is necessary to determine the cause of the cracking. While this may seem obvious, it is not always done. For example, the

repair of cracks caused by corroding reinforcement without remedying the cause of the cracking will inevitably provide only a short-term solution.

Dormant cracks, i.e. those judged not likely to move further, have traditionally been filled by chasing them out and then sealing them with a cement grout or mortar. Whilst this is still an effective method in many cases, many other material types are now available which are more effective, albeit more expensive. They include epoxy resins, polyester resins and synthetic latex.

Live cracks, i.e. those judged to be still moving, require a sealant to be flexible if it is to be effective (e.g. polyurethane resins, acrylic gels and flexible epoxy resins). Since there are such a wide variety of these materials available, it is not possible to give detailed instructions on their usage. What follows is intended to provide general guidance only. More detailed information should be sought from the manufacturers of particular products.

Dormant Cracks

Dormant cracks may range in width from 0.05 mm or less (crazing) to 5 mm or more. Obviously, the width of the crack will have considerable influence on the materials and methods chosen for its repair.

Very fine cracks (e.g. crazing) are very difficult to repair effectively and in many cases the best option may be to do nothing. Autogenous healing of very fine cracks may occur with time.

If the problem is an aesthetic one, rubbing down the surface with a grinding stone followed by sealing with a water-repellent material (such as sodium silicate) may provide a solution. Dirt, collecting in very fine cracks, tends to accentuate them.

Fine cracks, those up to about 1 mm in width, may often be sealed against water penetration by simply rubbing in a cement grout or slurry. The grout may be modified with a styrene butadiene or styrene acrylate polymer to increase adhesion.

Fine cracks may also be sealed by injecting them with either a cement grout or an epoxy resin. Epoxy resins have been produced for

this purpose and low viscosity formulations are available which will penetrate cracks as fine as 0.1 mm in width, or less.

Epoxy grouts are widely used because:

- They adhere strongly to both fresh and hardened concrete;
- Formulations are available which will adhere to most surfaces and harden even under wet conditions;
- They have good mechanical strength and low shrinkage;
- They are resistant to a wide range of chemicals, including alkalis.

Epoxy grouts are normally injected under pressure. Nipples or injection points are fixed along the line of the crack and the surface is then sealed on both sides of the cracked element should this be necessary. The epoxy is then injected under pressure using specialised equipment. In some instances, a vacuum may first be applied to the crack to exhaust the air and assist the inflow of resin when the vacuum is released.

Wider cracks (over 1 mm in width), may also be sealed by injecting epoxy resin and particularly cracks on vertical surfaces. On horizontal surfaces it may be possible to simply pour the grout into the crack. For cracks wider than say 2 mm, a cement grout may be the most satisfactory, and is often preferred because of its total compatibility with the parent material and its ability to maintain an alkaline environment around reinforcement.

Other materials, such as polyester resins and synthetic latexes, have also been used satisfactorily to seal fine cracks. They can have lower viscosities than epoxies and, hence, can penetrate more easily. However, they may not achieve the same bond strengths and may be less reliable in damp or wet conditions. Polyvinyl acetate, for example, is water soluble.

Live Cracks

Live cracks must be sealed with a flexible material which can accommodate the movement in the crack. This is especially so when cyclic movements are anticipated.

Flexible epoxy resins are available which will accommodate a small amount of movement, but the more usual procedure is to choose a mastic, thermoplastic or elastomer.

Mastics are generally viscous liquids such as non-drying oils, butyl rubber or low melting asphalts. They are used in conjunction with a groove or chase cut into the surface of the crack which is then filled with the mastic. These are likely to be the lowest cost of the available sealants, but their use is restricted to vertical surfaces or horizontal surfaces which are not trafficked.

Movement in the crack, particularly in hot weather, may cause the sealant to extrude.

Thermoplastic materials are those which soften and become liquid or semi-liquid at higher temperatures, normally in excess of 100°C. Although less susceptible to temperature than mastics, they suffer from similar disadvantages.

Elastomers include a wide range of materials, such as polysulphides, polyurethanes, silicones and various acrylics. Some are one-part, and some are two-part materials. They have advantages in that they are less susceptible to temperature in the normal range experienced in buildings and other structures, adhere strongly to concrete and are able to accommodate significant movements without failure. Reference should always be made, however, to the information supplied by the manufacturer to ensure the correct application of particular products to particular situations.

6. REFERENCES

- 1) AS 3600 – *Concrete structures*
- 2) SA HB 84 – *Guide to concrete repair and protection*

This section contains information on the precautions which should be taken when concreting operations have to be carried out in either very hot or very cold weather. While what constitutes hot and cold weather is nowhere specifically defined, AS 1379 *'Specification and supply of concrete'* requires that concrete temperatures at the point of delivery be within the range 5°C to 35°C. Precautions will always be necessary when ambient temperatures lie outside this range, but may well be necessary even when they lie within it. AS 1379 suggests protective measures may need to be taken when the air temperature is less than 10°C or more than 30°C. A knowledge of the effect of high and low concrete-temperatures on the properties of concrete will enable sensible decisions to be made on when precautions are needed and what precautions are necessary.

CONTENTS

1. INTRODUCTION	2
2. CONCRETING IN HOT WEATHER.....	3
2.1 EFFECT OF HIGH CONCRETE TEMPERATURES	3
2.2 CONTROLLING CONCRETE TEMPERATURE.....	4
2.3 BATCHING, MIXING AND TRANSPORTING	5
2.4 PLACING AND COMPACTING.....	6
2.5 FINISHING AND CURING	6
2.6 PLASTIC CRACKING	7
3. CONCRETING IN COLD WEATHER	9
3.1 EFFECTS OF LOW CONCRETE TEMPERATURES	9
3.2 ADMIXTURES.....	10
3.3 HOT WATER	10
3.4 CEMENT TYPE AND CONTENT .	11
3.5 FREEZING CONDITIONS	11
3.6 STRIPPING FORMWORK.....	12
4. SUMMARY – CONTROLLING THE EFFECTS OF HOT AND COLD WEATHER	13
5. REFERENCES.....	14
6. RELEVANT AUSTRALIAN STANDARDS.....	14

1. INTRODUCTION

It is generally well recognised that when concrete is mixed and placed in either very hot or very cold weather, it is necessary to take

precautions to ensure that the concrete is not damaged or adversely affected by the ambient weather conditions. At temperatures below freezing, for example, freshly placed concrete may be damaged by the formation of ice within its pore structure. In very hot weather the concrete may stiffen prematurely preventing it from being compacted and finished properly, or the temperature of the concrete may rise to a point where thermal cracking becomes a real risk as the concrete cools.

It should also be noted that temperature is not the only environmental condition that has the potential to impact concrete performance. Strong drying conditions (created by moderate to high temperatures, low humidity and strong winds) can cause major problems for plastic concrete – the most important being plastic shrinkage cracking.

There are few fixed rules, therefore, on what constitutes 'hot' or 'cold' weather with respect to concreting operations. AS 1379 requires that concrete temperatures at the point of delivery be within the range 5°C to 35°C. Precautions will always be necessary when air temperatures lie outside this range.

Precautions may well be necessary at air temperatures within the 5-35°C range and care may be required with ambient temperatures of <10°C or >30°C. In the lower temperature environment, the concrete is in no danger of freezing but it may take an excessively long time to set and to gain its specified strength. In the higher temperature environment, particularly if accompanied by hot dry winds, premature stiffening and plastic shrinkage cracking of the concrete may occur.

This section will provide guidance on (a) the effects of high and low temperatures on the

properties of concrete; and (b) in light of these effects, on precautions which should be taken when air temperatures fall outside the 'normal' range (say 10°C to 30°C), or when strong drying conditions prevail.

2. CONCRETING IN HOT WEATHER

High ambient temperatures, particularly when combined with strong dry winds, can affect the quality of both fresh and hardened concrete in a number of ways:

- By heating the constituent materials, notably the aggregates, they can increase the temperature of the freshly mixed concrete to the point where slump loss, increased water demand, and reduced setting times may occur;
- By causing the surface of the plastic concrete to dry prematurely, cracking (known as plastic shrinkage cracking) can occur when stresses induced by moisture loss and consequent shrinkage exceed the tensile capacity of the plastic concrete;
- By accentuating the temperature rise in concrete caused by the hydrating cement, particularly in massive sections, they can lead to thermal shrinkage or shock-induced cracking when the concrete subsequently cools.

2.1 EFFECT OF HIGH CONCRETE TEMPERATURES

As the temperature of concrete rises the hydration reactions are accelerated where (a) the setting time is reduced, and (b) the time available in which to place, compact and finish the concrete is also reduced. More water is often added to the mix to maintain or restore workability with a consequent loss in both potential strength and durability. Where water is not added, the reduced setting time increases the dangers of incomplete compaction, or the formation of cold joints or poor finishes (**Figures 18.1 and 18.2**).

Even when potential strength and durability are maintained, by the addition of cement to the

mix for example, the final strength of the concrete may be reduced because of the higher temperatures (**Figure 18.3**). It should also be noted that, whereas increased early-age concrete temperatures result in an increase in the early strengths and rate of strength gain, in the longer term, concretes cured at the lower temperatures achieve higher ultimate strength (see also **Figure 18.7**). Curing concrete at temperatures between 10°C and 25°C tends to achieve optimum results.

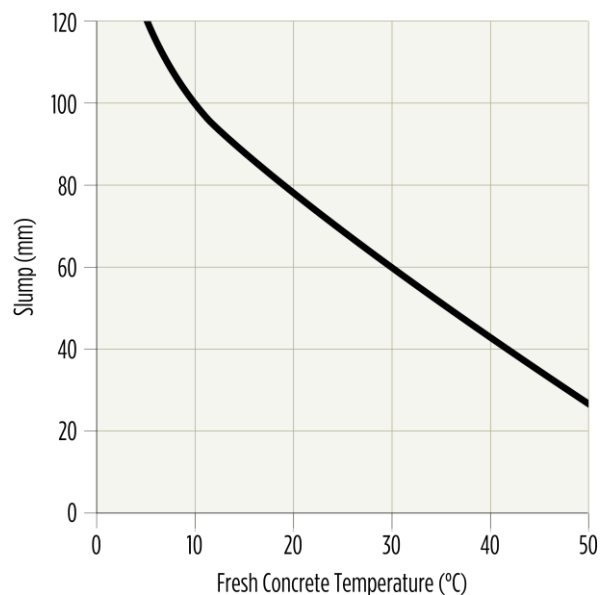

Figure 18.1 – Decrease in Workability of Plastic Concrete (measured by slump) as Temperature Increases – at Constant Water Content

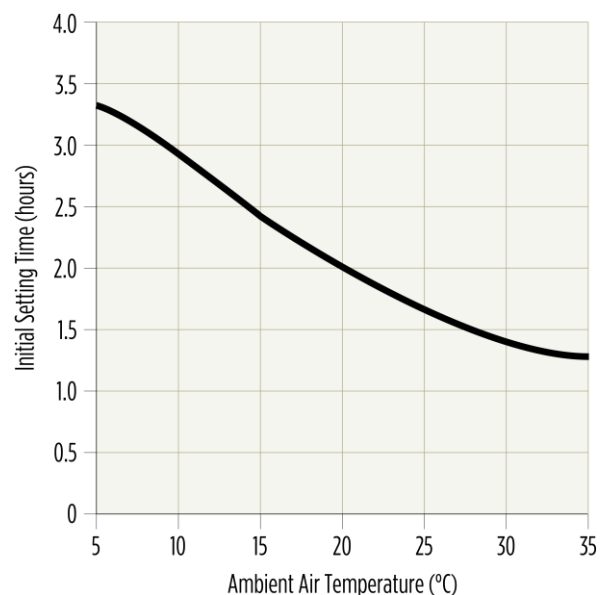

Figure 18.2 – Influence of Air Temperature on Initial Setting times of Concrete made with Type GP Cement

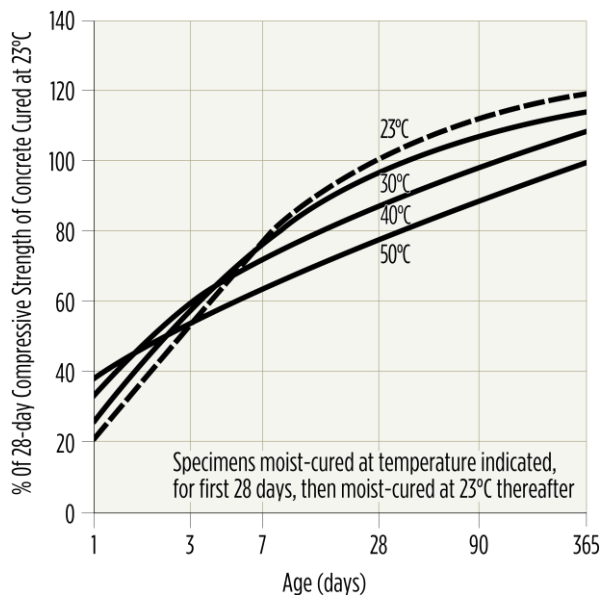

Figure 18.3 – Effect of High Curing Temperatures on Concrete Compressive Strength

2.2 CONTROLLING CONCRETE TEMPERATURE

Estimating the Temperature of Fresh Concrete – The temperature of fresh concrete may be estimated from the following equation:

$$T = (T_a W_a + T_c W_c + 5T_w W_w) / (W_a + W_c + 5W_w)$$

.....Eq.18.1

Where:

- T = temperature of the freshly mixed concrete in (°C);
- T_a = temperature of the aggregates in (°C);
- T_c = temperature of the cement in (°C);
- T_w = temperature of the mixing water in (°C);
- W_a = mass of aggregates including free moisture (kg);
- W_c = mass of cement (kg);
- W_w = mass of mixing water (kg).

NOTE: This equation gives approximate results only but is sufficiently accurate for most practical purposes. For more accurate results knowledge of the specific heats of the constituent materials is necessary.

By substituting typical mix proportions in the above equation, it can be seen that the aggregates (and their temperature) have a dominating effect on the temperature of freshly

mixed concrete – since they are (by mass) the dominant material. Next in importance is the temperature of the mixing water. The cement has a relatively minor effect unless its temperature is much higher than that of the other materials. The effect of higher cement temperatures can be easily calculated.

Aggregates – As the temperature of the aggregates has the most significant influence on concrete temperature, measures taken to limit aggregate temperatures have the greatest effect in minimising the temperature of freshly mixed concrete. Shading stockpiles from the sun and/or keeping them moist with sprinklers are commonly used means of reducing aggregate temperatures. Storage in bins (painted white) can also assist.

Water sprays, continuously applied as a fine mist (for evaporative cooling), are particularly effective and serve also to suppress dust in hot, dry and windy conditions. Adequate provision for drainage and/or recycling of the water must be made to prevent the storage site becoming problematic. A continuous spray is preferable to intermittent spraying to maintain a constant moisture content in the aggregates and thus minimise variations in concrete water/cement ratio.

Water – The temperature of the mixing water may have a significant effect on the temperature of the concrete. If water is stored on site in tanks unprotected from the sun it may become quite hot. Conversely, if cooled by refrigerating the mixing water or by adding crushed ice to it, it will serve to lower the temperature of the concrete and help offset higher temperatures in the other materials.

Typically, water will be drawn from town water supplies. In such cases, reticulation lines should be shaded and lagged to protect them against solar radiation. Intermediate surge or storage tanks should be similarly protected. If bore water is being used an awareness of any temperature variability in this water source will assist in management of concrete temperatures.

Cement – The temperature of cement does not usually contribute significantly to the temperature of freshly mixed concrete because

of its low specific heat combined with its relatively small mass in the mix. Nevertheless, temperature rise can be avoided by painting silos white (or other reflective colours).

The type of cement will affect the properties of the freshly mixed concrete and advantage of this may be taken in some situations. Blended cements and low heat cements may provide additional time for placing and finishing, depending on the proportion of fly ash and/or slag used in the mix.

The use of rapid-hardening cement should be avoided except where very rapid strength gain is necessary.

Admixtures – Admixtures are very helpful in offsetting the effects of hot weather and high concrete temperatures. They may be used to improve and maintain the workability of the concrete without the addition of extra water and also be used to retard setting.

There is a growing reliance on admixtures to manage plastic concrete properties. It is still appropriate though to manage the temperatures of other constituent materials and to maintain good practices in the transporting, placing and curing of the concrete.

Ice Addition – A proportion of the mixing water can be replaced with crushed or flaked ice. Ice is typically added manually to the truck during batching where the concrete temperature needs to be limited, commonly on mass or large concrete pours. Ice addition can also be directly fed to the agitator truck or mixer from flaked ice plants, however these are uncommon in Australia and have only been used on large projects. The amount of ice that can be used is limited by the water content of the concrete.

Liquid Nitrogen Injection – For large and important pours where temperature control is critical, cooling may be achieved by injecting liquid nitrogen directly into the mixer or agitator truck (**Figure 18.4**).

The quantity of liquid nitrogen used is adjusted to the temperature of the constituent materials and, in this way, effective (but expensive) control of concrete temperature can be

maintained. Injection lances, storage tanks, etc are available from the suppliers of industrial gases. Generally, liquid nitrogen injection is only used in large volume projects where good temperature control is required. A common use is in mass concrete pours where concrete temperature management is critical.



Figure 18.4 – Injection of Liquid Nitrogen into an Agitator Truck to lower Concrete Temperature

2.3 BATCHING, MIXING AND TRANSPORTING

To minimise the effect of high ambient temperatures on the concrete during the batching, mixing and transporting operations, a number of simple precautions can be taken:

- All handling equipment such as chutes, conveyors and pump lines should be either enclosed or alternatively shaded and painted white (or in a reflective colour);
- Site mixers themselves should be shaded and/or painted white;
- Transport from the mixer to the site, and on the site itself, should be planned carefully to minimise transport time and avoid unnecessary delays. Transit mixer trucks should be discharged as quickly as possible after the water has been added to the mix. Prolonged mixing should be avoided.

Fortunately, these precautions tend to coincide with the need (in urban areas at least) to

minimise noise and dust pollution of the environment.

2.4 PLACING AND COMPACTING

Formwork and Reinforcement – Wherever possible, subgrades, formwork and reinforcement should be shaded to minimise surface temperatures and should also be cooled by (carefully) spraying with water prior to concrete being placed. A fine mist spray is well suited to this purpose, but care must be taken that water does not collect on the subgrade or in the forms. Surfaces at the time of concreting should preferably be damp – but not wet.

Placement – As far as is practical, concrete placement should be carried out in the cooler parts of the day. For most of Australia this is in the early morning. This permits the concrete to be finished before the hottest part of the day and makes it easier for curing to be commenced immediately.

In very hot areas night-time pours may be advantageous, particularly for mass concrete structures.

Because the time during which the concrete remains workable is generally reduced in hot weather, the provision of stand-by equipment and/or additional manpower to eliminate any delays (e.g. due to breakdowns) becomes more crucial in these environments.

Placing of slabs should be organised so that a 'minimum' front is employed to which fresh batches of concrete are added. Concrete walls and deep beams should similarly be placed in shallow layers to avoid any 'cold joints' which might occur when fresh concrete is placed against concrete already stiffened.

2.5 FINISHING AND CURING

Finishing – Two separate (albeit related) problems may be experienced in finishing concrete during hot, dry and windy conditions.

First, the time available in which to finish the concrete is generally reduced under these conditions. Finishing operations should therefore be carried out promptly once the

water sheen has disappeared from the concrete surface and it is strong enough to support the weight of a person. Temporary sunshades and windbreaks will assist to lengthen the time during which finishing can be done.

(NOTE: Care needs to be taken when starting finishing operations to ensure that the concrete has actually reached initial set and that the surface has not simply dried out leaving the lower sections of the slab still in a plastic state.)

The second problem which may occur in hot, dry, windy conditions (or even at moderate temperatures when there are strong dry winds) is known as plastic shrinkage cracking (PSC). PSC can occur when the surface of the freshly placed concrete is allowed to dry out rapidly, generally before the body of the concrete has had time to take its initial set and has gained any reasonable tensile strength.

Under these conditions fine cracks may open in the surface of the concrete. While they may sometimes be closed over during finishing operations, they constitute a line of weakness in the surface and the cracks will often open up again as the concrete dries out following curing operations, or later when the hardened concrete undergoes drying shrinkage. Special care is necessary in extreme weather conditions to prevent this occurrence. A range of precautions are further discussed below (see 2.6 'Plastic Cracking' below).

While the concrete is still plastic and unable to be cured by conventional means (see Section 15 'Curing') loss of moisture due to evaporation can be minimised by spraying aliphatic alcohol onto the surface of the bleed water. (Aliphatic alcohol is available from manufacturers of concrete admixtures.) It forms a thin film on the bleed water and reduces evaporation significantly in evaporative conditions without interfering with subsequent finishing operations. This approach is particularly useful for the prevention of plastic shrinkage cracking.

Curing – Curing should commence as soon as practical after finishing to prevent moisture being lost prematurely from exposed, hardened concrete surfaces.

As soon as the concrete has hardened and finishing is complete, normal curing procedures should be commenced.

In hot, dry conditions, water curing is the preferred method because it not only ensures that the concrete is kept moist but also assists in cooling the concrete while it hardens and gains strength. The use of a wet covering such as hessian is particularly useful for this purpose as it also shades the concrete. Hessian should be kept continually wet with a fine mist of water (which minimises water usage) or more simply, with soaker-hoses. Care should be taken that the temperature of the water is not higher (nor significantly cooler) than that of the concrete. High spray water temperatures may be the result of exposed reticulation lines. Where adequate water supplies are available, and project circumstances allow, water curing should be maintained for at least seven days.

In situations where water is not readily available, or even when site conditions are not favourable, every effort should be made to water cure for at least 24 hours. It should be followed immediately by some other form of curing (e.g. the application of a suitable curing compound or the use of a protective membrane such as plastic sheeting).

Where plastic sheeting is used in hot, windy weather it is essential that it be well secured and anchored at the edges and joints or much of its effectiveness will be lost. There is always the danger that the sheeting can be torn or blown off in strong winds.

2.6 PLASTIC CRACKING

Plastic cracking – the formation of cracks in the surface of the concrete before it has reached its initial set – may be caused in several ways:

- By drying out of the surface of the concrete before the body of the concrete has set (and gained some strength);
- By settlement of the concrete around reinforcing bars, aggregate particles or other obstructions;
- By settlement or movement of the formwork.

Cracks caused by settlement of the concrete and/or the formwork issues are discussed in Section 17 'Control of Cracking in Concrete'.

Plastic Shrinkage Cracking – Plastic shrinkage cracks, i.e. cracks caused by too rapid drying out of the surface of plastic concrete, most often occur in hot, dry, windy conditions but are not unknown at even quite moderate temperatures if the wind velocity is high enough and/or the relative humidity is low (**Figure 18.5**). The primary cause is the rapid loss of moisture from the surface of the concrete by evaporation. Shrinkage caused by the loss of moisture creates tensile stresses in the plastic concrete at a time (at about initial set) when the tensile capacity of the concrete (i.e. the ability to resist tensile stress) is at its lowest. Plastic shrinkage cracks are often full thickness cracks and generally do not extend to the edge of the concrete slab (due to lower levels of restraint at the edges).



Plastic Shrinkage cracking

Figure 18.5 – Plastic Shrinkage Cracking (PSC)

Figure 18.6 may be used to estimate the likelihood of plastic shrinkage cracking occurring and, hence, the need for suitable precautions to be taken. As can be seen from the nomograph, the factors which affect the rate of evaporation of moisture from the surface include:

- Air temperature;
- Relative humidity;
- Concrete temperature;
- Wind velocity.

Where these factors combine to produce a rate of evaporation of $1 \text{ kg/m}^2/\text{h}$ or above then PSC

is likely, and precautions must be taken. As has been noted, high air temperatures are not necessary for these evaporative conditions to occur – concrete temperature, wind velocity

and humidity actually have greater effects. At evaporation rates of 0.5 kg/m²/h there is a reasonable risk of PSC and precautions should be applied.

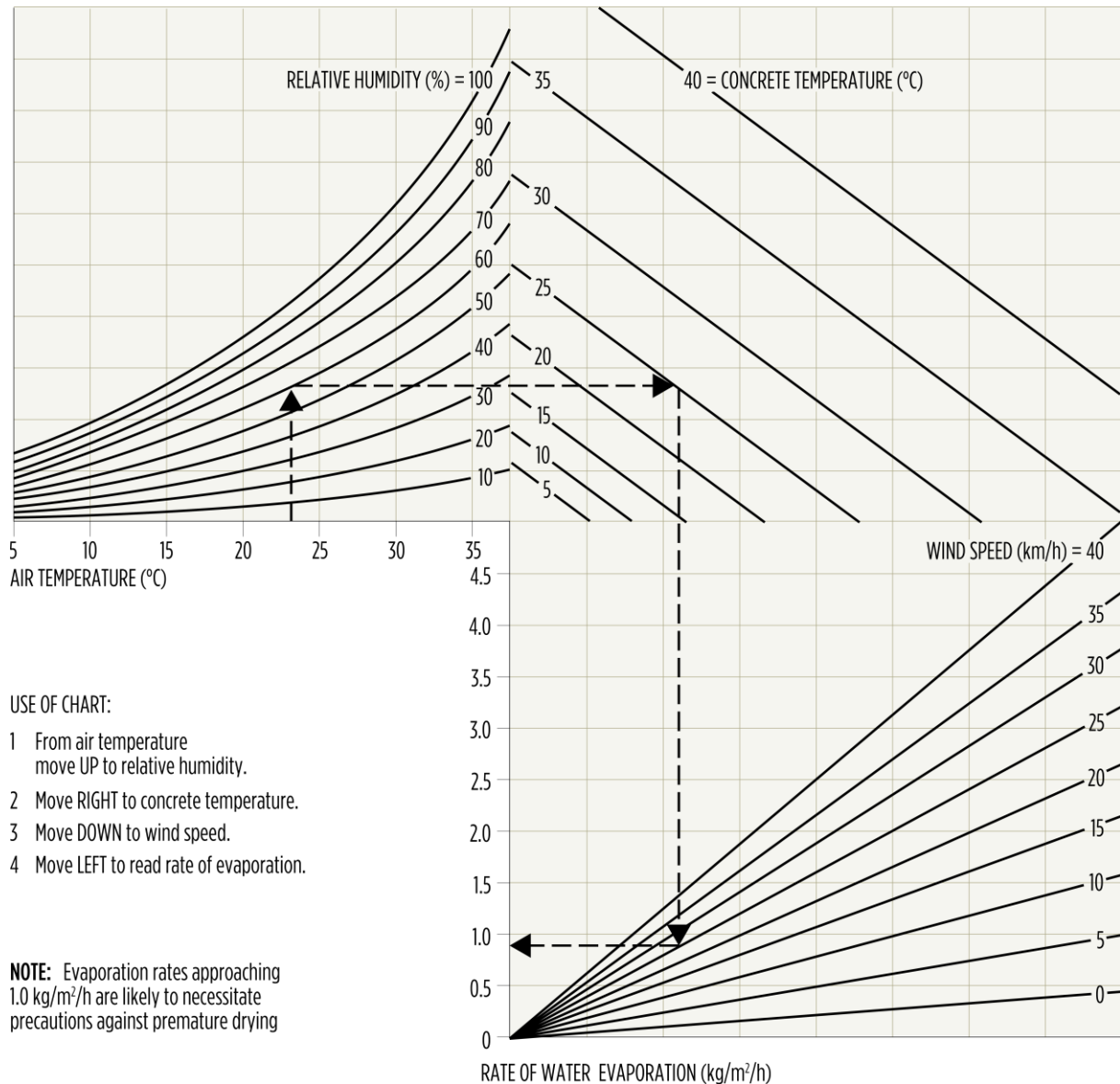

Figure 18.6 – Effect of Concrete and Air Temperatures, Relative Humidity and Wind Velocity on the Rate of Evaporation of Surface Moisture from Concrete (after ACI-305 (1999) [2])

It should also be noted that actual site weather conditions may be quite different to (for example) BOM weather forecasts or data. A location on the top of a hill will have a different evaporation rate to that in an adjacent valley. Shaded or wind-protected areas in the same locale will also result in different evaporation rates. Similarly, wind-tunnel effects between adjacent buildings will result in higher

evaporation rates than might otherwise be expected. It is also important to realise that evaporation rates change through the day – with wind velocity generally increasing and the sun moving overhead, both increasing evaporation potential. Where there are concerns about PSC risk, starting concrete placing as early as possible in the day is advisable.

As an alternative to using the nomograph in **Figure 18.6**, the equation shown below can be used to estimate evaporation rates. Both methods are based on evaporation from a water surface and are not applicable after bleed water disappears from the surface of the plastic concrete.

Alternative equation to calculate evaporation rate [1]:

$$E = 5([T_c + 18]^{2.5} - r[T_a + 18]^{2.5})(V + 4) \times 10^{-6}$$

.....Eq.18.2

Where:

- E = evaporation rate (kg/m²/h);
- r = Relative Humidity/100;
- T_a = air temperature (°C);
- T_c = concrete (water surface) temperature (°C);
- V = wind velocity (km/h).

Precautions – The most effective way to reduce the risk of PSC is to prevent rapid loss of moisture from the surface of the plastic concrete. Practices to achieve this include:

- Dampen subgrade and forms (but ensuring any excess water is removed prior to placing concrete);
- In hot weather – lower the temperature of the fresh concrete by using cool aggregates and chilled mixing water;
- Start placing concrete as early as possible in the day;
- Add polypropylene fibres to the concrete mix [3];
- Erect wind breaks to reduce wind velocity over the concrete surface;
- Spray aliphatic alcohol sprayed on bleed water to reduce its rate of evaporation from the surface;
- Commence curing promptly after finishing is complete and ensure the surface is subject to continuous curing.

Re-vibration – If PSC does become evident before the concrete has reached initial set, the cracks may be able to be closed by re-vibration of the concrete over the full depth of the cracks. The feasibility of doing this should be assessed by an experienced operator, but a good rule of

thumb is to permit re-vibration of concrete only if the vibrator will sink into the concrete under its own weight. Surface re-vibration may be only partially effective as it may not close the cracks to their full depth. Partially closed cracks will almost certainly reappear as the concrete dries out.

PSC often appears immediately before initial set and in surfaces that have dried out. These conditions are not generally conducive to re-vibration.

3 CONCRETING IN COLD WEATHER

In Australia, freezing conditions are generally encountered only in the southern mountains of NSW, and in Victoria and Tasmania, although frosts are not uncommon over wide areas of inland Australia during the winter. Most often, concreting in cold weather in Australia entails operations in ambient temperatures above freezing, but temperatures still low enough to have potentially adverse effects on the progress of the work and the setting of concrete.

3.1 EFFECTS OF LOW CONCRETE TEMPERATURES

By reducing the rate at which the cement hydrates, low concrete temperatures have a number of effects on the behaviour of the concrete. Firstly, and most noticeably, the setting time will be increased, delaying concrete finishing operations (**Figure 18.2**). At low temperatures, bleeding will continue for longer and bleed water will take longer to evaporate.

Under these conditions, there is a temptation in finishing flatwork to use 'driers' (cement or mixtures of cement and sand applied to the surface of the slab) to 'mop up' excess water to allow finishing to proceed. This practice leads almost inevitably to poor abrasion/wear resistance.

Further, if the low temperatures are prolonged, the concrete will take longer to harden and gain strength, thereby requiring the removal of

formwork to be delayed (**Figure 18.7**). AS 3600 (Clause 17.6.2) sets out minimum periods for which formwork and formwork supports must be left in place – periods which vary with the average ambient temperature over the period specified (**Table 18.1**).

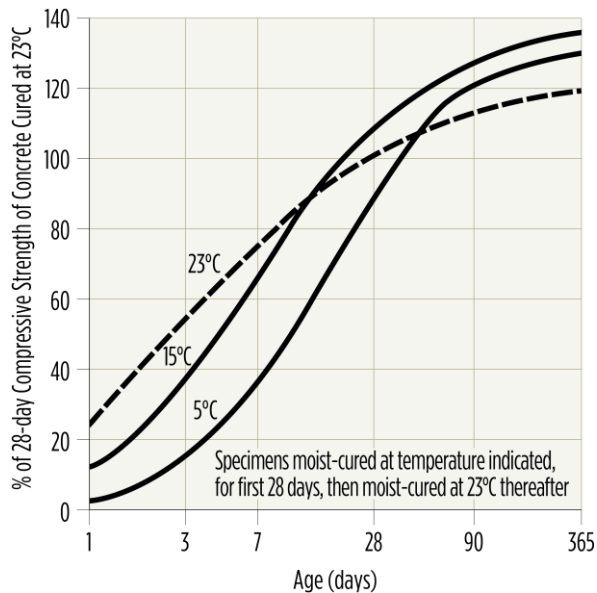

Figure 18.7 – Effect of Low Temperatures on Concrete Compressive Strength

When freezing conditions are encountered, irreversible damage may be done to the concrete while it is still plastic or when it is starting to harden (see 3.5 ‘Freezing Conditions’).

3.2 ADMIXTURES

The most commonly used method of offsetting the effects of cold weather is the addition of an accelerating admixture to the concrete. There is a wide variety of these, ranging from water-reducing admixtures which have had accelerators incorporated in them to chemicals whose sole purpose is to reduce the setting time and accelerate the rate of strength gain (see Section 5 ‘Admixtures’).

Accelerating admixtures increase the rate at which the cement hydrates, increasing the rate of strength gain and result in higher levels of heat generation which leads to higher concrete temperatures.

Accelerators may perform a very useful purpose, but their use should be approached with caution. Any accelerating admixtures containing chlorides should be avoided. If these must be used, the chloride content must be known and a check made to ensure that the limits on the chloride content of concrete, as noted in AS 1379, are not exceeded.

Table 18.1 – Stripping/removal Times (based on Tables 17.6.2.4 and 17.6.2.5 in AS 3600)

Average ambient temperature over the period T (°C)	Period of time before stripping of formwork from reinforced slabs continuous over formwork supports – Normal-Class concrete with specified early-age strength (days)	Period of time before removal of all formwork supports from slabs and beams not supporting structures above – reinforced members only* (days)
T > 20	4	12
20 ≥ T > 12	6	18
12 ≥ T > 5	8	24

NOTE: * Where the average ambient temperature over the period is less than 5°C or the superimposed construction load is greater than 2 kPa these periods will need to be increased.

3.3 HOT WATER

The use of hot water is another common method of compensating for the effects of cold weather. Its use as mixing water raises the temperature of the concrete which increases the rate at which the cement hydrates.

The temperature of mixing water should never exceed 70°C however, to ensure that ‘flash setting’ of the cement does not occur.

Care should also be taken to ensure consistency in the temperature of the concrete delivered to the site. Significant variations in the temperature of batches of concrete can lead to variations in the setting time of the

different batches, thereby complicating finishing operations. Sufficient heating capacity should be available at the concrete plant to ensure an adequate supply of hot water.

3.4 CEMENT TYPE AND CONTENT

The type of cement and the amount used will also have a bearing on the performance of concrete in cold weather. High-early strength cements (Type HE) will tend to set more quickly than general purpose (Type GP) cements, but the difference is not particularly significant. Hardening or strength gain will proceed more rapidly with a Type HE cement.

Blended cements (Type GB) have a range of characteristics, depending on the blend, but in general will tend to set and gain strength more slowly than Type GP cements.

Of greater significance is the amount of cement used in the concrete. Whilst this has little or no impact on setting time, except with low cement content mixes, the rate of strength gain can be increased significantly with higher cement contents.

3.5 FREEZING CONDITIONS

Freshly placed concrete is vulnerable to freezing conditions both before and after it has stiffened. If allowed to freeze while still plastic, the damage done to the pore structure of the cement paste (water expands as it freezes) is such that the potential strength of the concrete will be drastically reduced. Freezing of concrete which has partially hardened will also damage it, the extent of the damage depending on its age and strength when frozen.

Precautions in Freezing Conditions – It is always desirable to take precautions against freezing when the air temperature drops below 5°C. At the very least the concrete temperature should be maintained above 5°C to ensure that setting occurs within a reasonable time and that the concrete gains strength. Damage to the concrete by any sudden and unexpected frost will thereby be minimised.

If there is any likelihood that the temperature will drop below zero and freezing conditions ensue, then additional precautions will be required.

Form Insulation – Concrete can be protected and kept from freezing – at least until it has started to harden and gain strength – by the use of insulated formwork and protective covers. During the first 24 hours, hydrating cement gives off a significant amount of heat which, if retained within the concrete by insulation, will protect it from freezing.

Timber formwork is a reasonably adequate thermal insulator and will probably suffice for moderately cold conditions. Additional insulation will be required for more severe conditions or for prolonged periods of freezing weather.

Metal formwork offers little or no insulation protection and should be insulated.

Insulating materials should themselves be waterproof or be protected by tarpaulins, plastic sheeting, or other means, to keep them dry. While materials such as straw and some insulating boards are excellent insulators when dry, they are ineffective when wet. Expanded polystyrene sheets are relatively unaffected by moisture.

Heated formwork may also be employed to protect concrete against freezing over longer periods. These systems tend to be quite sophisticated, however, and are beyond the scope of this Guide.

Heated Enclosures – In some circumstances the use of a heated enclosure to completely encase the concrete element may be a satisfactory alternative. This may take the form of light frames covered with tarpaulins or similar material; or, in some cases, larger heavier frames with sheeting covers, within which work may be carried out during very cold weather. Heating these enclosures with hot-air blowers ensures an even distribution of heat within the enclosure.

Curing – Curing poses particular problems during prolonged periods of freezing weather. While loss of moisture from the concrete due to evaporation will be greatly reduced, very cold

air can be quite dry, and it may still be necessary to cure concrete to ensure that it achieves maximum potential durability.

Moist or water curing is rarely appropriate for obvious reasons.

Where the concrete has been placed in insulated formwork, covering the top surface of the member (preferably with an insulated covering) will serve to retain moisture within the member. When the formwork is removed, the member should be further cured by covering it with plastic film or waterproof tarpaulins, properly lapped at joints and secured to ensure wind-tightness. On no account should concrete released from insulated formwork or heated enclosure (and therefore warm) be saturated with cold water.

When protective measures are discontinued, care should be taken not to suddenly expose warm concrete surfaces to freezing conditions. With formwork, insulation and forms may be eased from the surface of the concrete but allowed to remain in place while the temperature of the surface falls slowly. With heated enclosures, the air temperature should be reduced slowly.

When hot-air blowers are used to heat enclosures, it should be noted that the air will be very dry unless humidified. Either (a) the use of fine mist sprays within the enclosure, or (b) placing trays of water in the path of the moving air, are advisable to prevent the concrete from drying out.

3.6 STRIPPING FORMWORK

Concrete that has been kept warm in an enclosure or with insulated formwork will quickly reach a strength (about 2 MPa) which will allow it to resist frost. At this point, vertical formwork may be removed. However, unless the formwork is required elsewhere, it will be advantageous to leave it in position as this will accelerate the hardening process and shorten the time to removal of soffit boards and props. By maintaining a record of the curing temperature of the concrete an assessment of its strength can be made at a later time to assist

in determining when it is safe to remove loadbearing formwork.

As was noted above, in stripping forms care should be taken not to expose warm concrete to low temperature conditions too suddenly. Care should be taken also to prevent too great a temperature differential developing between the external surfaces and the interior of a concrete section. This is of particular significance with massive structures which may take some time to cool down. Even after forms have been removed it may therefore be desirable to continue to insulate the concrete.

In the absence of more specific information such as a record of the temperature of the concrete, guidance on permissible stripping times may be obtained from **Table 18.1**.

4 SUMMARY – CONTROLLING THE EFFECTS OF HOT AND COLD WEATHER

Aspect	In hot weather	In cold weather
Pre-planning	<ul style="list-style-type: none"> • Pre-plan carefully to avoid delays at all stages; • Have standby equipment and manpower available for all stages; • Pay particular attention to speed of application, effectiveness and duration of curing arrangements; • Schedule night-time placement if possible, or early morning. 	<ul style="list-style-type: none"> • Pre-plan carefully to ensure adequate equipment and manpower available especially if there is a likelihood of temperatures below 0°C.
Concrete	<ul style="list-style-type: none"> • Use water-reducing retarding admixtures in the concrete; • Reduce the temperature of the concrete by (in order of effectiveness): <ul style="list-style-type: none"> – Reducing temperature of aggregates; – Using liquid nitrogen injections in the mixed concrete; – Reducing temperature of mixing water (chillers or ice addition); – Using cement with lower heat of hydration; – Reducing temperature of cement. 	<ul style="list-style-type: none"> • Reduce the setting time of the concrete by (in order of effectiveness): <ul style="list-style-type: none"> – Heating mixing water (maximum 70°C); – Using (chloride-free) accelerating admixture; – Using higher cement content; – Using high early-strength cement.
Batching, mixing and transporting	<ul style="list-style-type: none"> • Shade batching, storage and handling equipment or at least paint with reflective paint; • Discharge transit mixer trucks as soon as possible. 	<ul style="list-style-type: none"> • Ensure an adequate supply of hot water (if being used) to ensure consistency between batches.
Placing and compacting	<ul style="list-style-type: none"> • Shade reinforcement, formwork and subgrades if possible and spray with water; • Ensure that slabs have minimum 'fronts' to which concrete is being added; • Place concrete in walls and deep beams in shallow layers; • Use burlap covers if there is any delay between load deliveries. 	<ul style="list-style-type: none"> • Thaw frozen subgrades and heat frozen forms (particularly steel) before placing concrete; • Warm, insulate or enclose handling and placing equipment; • Avoid delays in handling and placing.
Finishing and curing	<ul style="list-style-type: none"> • Use sunshades and windbreaks to lengthen finishing time (or if hot/dry winds are present, to control plastic shrinkage cracking); • For flatwork use aliphatic alcohol after initial screeding if hot/dry winds present; • Use re-vibration to correct plastic shrinkage cracking if possible; • Use water curing as the preferred method for at least 24 hours. 	<ul style="list-style-type: none"> • Maintain concrete temperature until safe strength reached by means of form insulation, insulated covers or heated enclosures; • Delay striking of formwork for as long as possible; • Avoid thermal shocks and temperature variations within a member. This includes not using cold water for curing and removing thermal protection measures gradually.

5 REFERENCES

- 1) Uno, P., '*Plastic Shrinkage Cracking and Evaporation Formulas*', ACI Materials Journal 95, 4 (July-August 1998), pp. 365–375
- 2) ACI Committee 305, '*Hot Weather Concreting*' ACI Manual of Concrete Practice, Part 2: Construction practices and inspection, pavements American Concrete Institute, Farmington Hills, USA (1999)
- 3) Berke, N S & Dallaire, M P '*The effect of low addition rates of polypropylene fibers on plastic shrinkage cracking and mechanical properties of concrete*', Fiber reinforced concrete: Developments and innovations SP-142 American Concrete Institute, Detroit, USA, (1993) pp. 19–42
- 4) CCAA Datasheet, '*Hot Weather Concreting*', (August 2017)
- 5) CCAA Datasheet, '*Cold Weather Concreting*', (September 2004)

6 RELEVANT AUSTRALIAN STANDARDS

- 1) AS 1379 – *The specification and supply of concrete*
- 2) AS 3600 – *Concrete structures*

GUIDE TO CONCRETE CONSTRUCTION

T41



CEMENT CONCRETE
& AGGREGATES AUSTRALIA

PART VI - Special Concrete Applications

Slip-forming is fundamentally a concrete placing method that (in most cases) does not rely on fixed formwork to hold the plastic concrete in place until it has hardened sufficiently for formwork to be removed. It relies on the plastic concrete being sufficiently stiff to hold its shape once it is no longer being supported by the slip-form. The advantages of using slip-forming include increased speeds of placing and reduced cost due to there being (generally) no formwork involved, which reduces both materials costs and labour costs. As will be discussed, slip-forming can be used to place structures in both horizontal and vertical planes – each producing its own challenges. Slip-forming stands in contrast with the various formwork systems described in Section 27 *‘Formwork’* in this Guide. While it is not unlike the climbing formwork described in Section 27, slip-forming may be more appropriately described as ‘gliding formwork’.

CONTENTS

1. INTRODUCTION	2
2. VERTICAL SLIP-FORMING	3
2.1 GENERAL	3
2.2 THE PROCESS OF VERTICAL SLIP-FORMING.....	3
2.3 PRODUCTION CONSIDERATIONS .	4
2.4 FINISHING AND CURING.....	5
2.5 SPECIFICATION OF VERTICALLY SLIP-FORMED CONCRETE	5
2.6 SAFETY ISSUES WITH SLIP-FORMS	6
2.7 VERSATILITY OF SLIP-FORMING ...	6
3. HORIZONTAL SLIP-FORMING	6
3.1 GENERAL	6
3.2 SLIP-FORMED CONCRETE PAVING	7
3.3 KERB PRODUCTION	9
3.4 KERB MIX SPECIFICATION.....	9
3.5 BARRIER WALLS.....	10
3.6 BARRIER WALL CONCRETE MIX SPECIFICATION	11
4 RELEVANT AUSTRALIAN STANDARDS	11
5 OTHER REFERENCES	11

1. INTRODUCTION

Slip-forming concrete is by no means a modern construction method, with its first use occurring in the first decade of the 1900’s. While slip-forming is not a commonly used method, it can be applied in a wide variety of applications where its use is appropriate, and where it provides advantages over conventional formwork systems. Slip-forming allows continuous concrete placing to occur. In the process, plastic concrete is introduced into the top of (effectively) continuously moving formwork to form a structure with no joints, and one which is not an assembly of discrete elements. The challenge is to optimise the formwork movement and the concrete performance characteristics so that the concrete exiting the formwork has hardened sufficiently to support its own weight and to resist any ‘slumping’ that might be caused by the placing (including compaction by vibration) of fresh concrete that is immediately adjacent to it. The main advantages of slip-forming include (a) the creation of joint-free concrete, and (b) improved cost efficiencies from not having to build and then strip formwork – with the resultant significantly lower labour costs. While in its initial applications slip-forming was used to build ‘vertical’ structures like grain silos, its use has now expanded into ‘horizontal’ applications like road paving and the manufacture of kerb and concrete road barriers. The two different approaches will be discussed separately below.

2. VERTICAL SLIP-FORMING

2.1 GENERAL

As previously mentioned, the first application of slip-forming occurred well over 100 years ago when it was used for the construction of silos and grain elevators. This activity occurred in the USA and developed over following decades to be applied not only to agricultural-related structures, but also to residential and commercial buildings. Vertical slip-forming was patented in 1917 by James MacDonald in Chicago, with the patent described as being 'for a device to move and elevate a concrete form in a vertical plane'. In the 1950's and 1960's, slip forming began to be applied more broadly in buildings in the USA and Canada, and also in mining and other industrial applications.

2.2 THE PROCESS OF VERTICAL SLIP-FORMING

In the first instance, foundations and 'wall starters' need to be constructed before the process of slip-forming can begin. These initial structures define the location of the final structure and provide a 'starting point' for the subsequent construction using the slip-forming process.

While there are a number of different approaches to slip-forming, a typical slip-forming system will comprise a structure on three levels. On the upper platform (or Top Deck) there will be equipment (e.g. reinforcing steel) storage and often a receival vessel for the plastic concrete. On the middle platform (or Working Deck) the actual concrete placement will be occurring, and it is critical that this deck is rigidly held to maintain the accuracy of the casting. On the lower platform (or Hanging Deck) workers are able to gain access to the concrete emerging from the formwork and are able to apply a finish to it if required (**Figure 19.1**).

The actual formwork – the slip-form panel – is typically 1-1.5 m high and made of steel plates. The form moves upwards at speeds that would typically be about 300 mm per hour.

Generally, the slip-form is kept full of plastic concrete, with the concrete being added in 100-250 mm layers as the slip-form is moved vertically at a rate that allows the concrete to reach initial setting when it is about 200-400 mm above the bottom of the slip-form. The slip-form panel is slightly inclined to allow the free movement of the form against the stiffening concrete. The slip-form is lifted gradually and incrementally (10-25 mm at a time) at a rate that is determined primarily by the setting characteristics of the concrete. The setting characteristics are in turn primarily determined by the nature of the cement and the ambient and concrete temperatures. Generally, no SCM's are used in the concrete for slip-forming as actual setting time and consistency of setting time are of paramount importance.

(NOTE: Where fly ash has been used in concrete for slip forming, colour bands resulting from variable carbon levels in the fly ash have also been observed.)

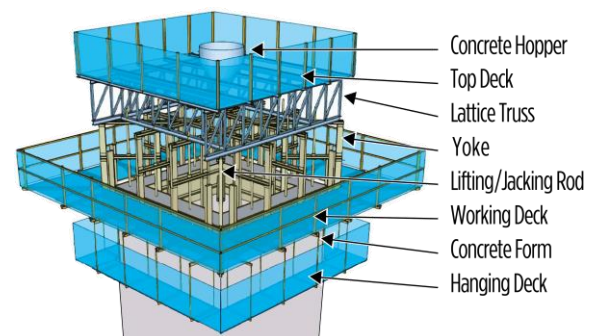

Figure 19.1 – General Structure used for Slip-forming

As important as the setting time characteristics are, so too are the workability characteristics. The concrete must have sufficient workability to be able to be fully compacted using the available compactive effort while not compromising the stiffness required in the formed concrete. Generally, the concrete mix design will have a higher than normal fines content and it has been noted that the use of rounded aggregates will improve workability. Concrete is delivered to the Top Deck either by pump or by crane and bucket and stored in a hopper prior to delivery to the slip-form.

As the slip-form moves upwards it is necessary to extend the reinforcing steel upwards. This steel is spliced or lapped against the steel

already located in the lower level concrete. The extra lengths of steel reinforcing are often secured against the Top Deck to keep it in place while the slip-form moves upwards.

Accuracy of the dimensions of the structure in both the horizontal and vertical planes is critical, and it is a primary function of the other components (e.g. jacks and support elements) of the slip-forming system to maintain this accuracy. In modern systems lasers are used to measure and monitor slip-forming accuracy. The levels of deviation typically expected/required in the horizontal direction are <5 mm for structures <3 m in height, or 1/600 of the height for structures >3 m in height. This accuracy is maintained in the horizontal direction using a system of horizontal tubes or by laser measurement, while vertical plumb is maintained by laser.

Movement of the slip-forming system is achieved through a hydraulic jacking system that is required to lift the slip-form evenly to maintain the required accuracy levels and at a rate sufficient to ensure that initial setting is achieved prior to the concrete exiting the form (Figure 19.2).

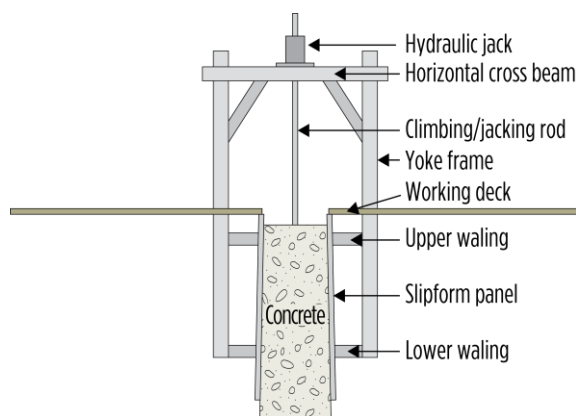

Figure 19.2 – Structural System used to Support and Raise Slip-form

While ‘vertical’ slip-forming is the norm, tapered slip-formed structures are also able to be produced where necessity or engineering/architectural design requires it (Figure 19.3).



Figure 19.3 – Tapered Slip-forming^{19.1}

2.3 PRODUCTION CONSIDERATIONS

The plastic concrete is supplied, often at 75-100 mm slump, via concrete pumps or via a bucket and crane system. Vibrators are used to compact the concrete when it is being placed. There should be sufficient plastic concrete in the form to provide a buffer between the concrete being compacted and the formed concrete below, otherwise the formed concrete can be damaged by the vibrators used to achieve compaction.

The setting characteristic of the concrete is a primary determinant of the rate of slip-forming able to be achieved. The setting characteristics are a function of the type of cement being used, the concrete temperature and the ambient temperature conditions. Retarding or accelerating admixtures can be used to match concrete setting times with required or expected slip-forming rates. If the slip-forming rate is too slow (relative to concrete setting) then cold joints may be formed and/or the form may adhere to the formed concrete surface and damage it. If the slip-forming rate is too fast (relative to concrete setting) then the formed concrete leaving the bottom of the form may not be self-supporting. In practice, slip-forming

rates are varied during a project because of changes in concrete setting performance.

When the slip-form is lifted, a shear zone forms on the outer edge of the plastic concrete, adjacent to the slip-form panel. This shear zone contains cement paste and fine sand particles which act as a lubricant as the panel is lifted. The lifting force required is determined in part by the workability of the concrete and the aggregate shape. The initial 'static friction' needs to be overcome – and once it is overcome the resistance to lifting is due to 'sliding friction' which can be calculated. The mix design can then be amended (in part through optimising the fines content and the air content) to ensure appropriate levels of sliding friction are able to be obtained as well as required setting times. The three key concrete mix performance properties are generally considered to be (1) slump, (2) setting time and (3) stability (i.e. lack of segregation).

Typical production rates achievable with slip-forming are heights of 3-5 m per 24-hour period, though in certain circumstances rates as low as 2 m or as high as 10 m per 24-hour period can be obtained.

While many slip-form operations are continuous, there are circumstances where (a) slip-forming needs to stop overnight (due to noise or other limitations in the inner-city) or (b) slip-forming stops over weekends for logistical considerations. In any of these cases a proper construction joint needs to be formed at the finishing point as for any other concrete construction activity.

If wall openings are required in the structure, then wooden frames and block-outs are placed into the plastic concrete at the working level and the rebar is then adjusted to accommodate the insertion. The block-outs can be stripped later from the lower platform (or Hanging Deck).

2.4 FINISHING AND CURING

Finishing of slip-formed concrete can be by two methods – wet finishing and dry finishing.

Wet finishing is applied immediately after the concrete emerges from the slip-form and entails the use of a rubber float to impart the final finish.

The dry finish is applied after the concrete has hardened and the forms have been removed. Typically, a dry finish involves the application of a skim coat or plaster to achieve a smooth final finish. Curing can be applied after the wet finish.

The quality of the surface finish with slip-formed concrete is often not as good as off-form finishes – with banding being a typical indicator of slip-formed concrete. This banding reflects the progressive vertical movement of the slip-form and, as previously mentioned, may be amplified by the presence of variable colours in the cement (or SCM's) or fine aggregates.

2.5 SPECIFICATION OF VERTICALLY SLIP-FORMED CONCRETE

The key requirements of slip-formed concrete in vertical structures and their relative importance will depend on the design of the structure and the construction program. Some typical requirements that are common to these projects are:

- A specified maximum initial set time and final set time for the concrete mix design;
- A minimum early age compressive strength at between 12 hours and 24 hours;
- A target slump on delivery that is commonly 80 mm but may be lower than this. Slump control is critical to the success of slip-forming for the purposes of achieving a uniform finish and uniform setting characteristics;
- Concrete temperature as delivered to site may also be tightly controlled with both a maximum and minimum allowable temperature likely to be applied;
- A maximum aggregate size in the concrete mix that is generally 20 mm but may be 40 mm in thicker walls (i.e. greater than 500 mm thickness);
- The general properties of normal class concrete are also specified and as the concrete is often placed using a concrete pump in vertical structures, the mix design will normally be required to be suitable for pumping.

2.6 SAFETY ISSUES WITH SLIP-FORMS

There are a number of safety considerations peculiar to the use of slip-forming. These have been considered in a Safe Work Australia (www.swa.gov.au) document 'Guide to Slip, Jump and Travelling Formwork Systems'. The particular concerns related to slip-forming include (a) the design of these systems is often more complex than is required for conventional formwork and requires specific engineering knowledge and expertise, and (b) problems with slip-forms may not be apparent until it is actually operating which requires a 'hands on' approach and ongoing contact with site personnel when assessing issues and making modifications if and as required. Detailed consideration needs to be given to minimum concrete strengths required to deal with live loads which are influenced by environmental conditions (e.g. wind) as well as possible eccentric loading of the structures. Entry and exit systems, edge-protection and dynamic loading when concrete is being delivered to the platforms are also key safety aspects.

When the slip-form is climbing it is important to ensure (a) level is maintained across the platforms and (b) service connections (e.g. electrical cables and water supply) are not snagged as the form rises. In the unusual conditions experienced with slip-forming, rigorous systems of inspection and maintenance are required to ensure the ongoing safety of the structure and personnel.

2.7 VERSATILITY OF SLIP-FORMING

The versatility of slip-forming is illustrated by reference to a variety of projects discussed in a recent publication [1]. This reference describes a number of modern structures created using slip-forming, including:

- Platforms used for oil-drilling in the North Sea – with slip-formed heights of up to 242 m and with variable-shape components. One of the largest platforms occupied a footprint of about 16,000 m² and contained some 114,000 m³ of 65 MPa concrete and about

14,000 tonnes of reinforcing steel. It was constructed over 42 days;

- LNG storage tanks of 75 m diameter, slip-formed at 2.5-3 m height increments per day with very strict tolerances;
- A 115 m high commercial building which incorporated 280 prefabricated beams which were incorporated during slip-forming – with the slip-forming operation being ceased from 10.00 pm to 6.00 am each day;
- A 143 m high concrete tower with a hexagonal base that inclined from the base to the top at an angle of 5.5°.

A range of other slip-forming projects have been completed under onerous conditions – including in both extreme heat and extreme cold – which attests to the versatility of the slip-forming process (**Figure 19.4**).



Figure 19.4 – Slip-forming of Fuel Tanks^{19.2}

3. HORIZONTAL SLIP-FORMING

3.1 GENERAL

There are three main categories of concrete structures created using horizontal slip-forming, namely paving, kerb and barrier walls. The most important of these is paving and the largest volume product type produced by slip-form paving is concrete roads. While concrete roads are very common in some overseas countries, particularly the USA, they are not being used extensively in Australia, except for NSW. Major highways in NSW, like the Hume Highway and the Pacific Highway, have long stretches of concrete paving and they seem to be performing well. Their success in NSW is probably best endorsed by their continuing

specification and use. While Queensland trialled concrete pavement in a couple of locations and then committed to an approximately 60 km stretch between Brisbane and the Gold Coast (which opened in about 2000), there has been no further significant commitment to concrete roads. In other states the use of concrete paving is minimal. Kerb and barrier wall, on the other hand, are routinely produced by slip-forming and extrusion processes and this is the situation nationally. Each of the slip-formed structure types will be discussed separately.

3.2 SLIP-FORMED CONCRETE PAVING

There are several types of concrete paving that can be produced by slip-forming. The three main types are (a) Plain Jointed Concrete Pavement (PCP), (b) Jointed Reinforced Concrete Pavement (JCRP) and (c) Continuously Reinforced Concrete Pavement (CRCP).

The use of paving machines for concrete roads/pavement began in about 1958 in the USA, while the first CRCP pavement was constructed in 1962 – again in the USA. Like any new technique, there was scepticism about whether concrete pavements could be reliably constructed, and particularly with those that were designed to contain reinforcing steel. There have been major engineering advances in the design, construction and operation of paving machines over the last several decades to the point where they are now considered to provide reliable and cost-efficient pavement construction. Essentially, low slump concrete is deposited in front of the machines, and in one pass of the machine the concrete is levelled, compacted and finished. The resulting pavement does not require formwork to hold it in place until setting has occurred. Post-paving there are several processes required including (a) applying a final finish by (typically) using either a tyne or a hessian drag, (b) applying curing compound by spraying, and (c) sealing joints with PCP and JCRP pavement types. Single-lane and double-lane pavers are now available, and they can place large areas of high-quality (smooth riding) pavement in a matter of hours. While most commonly used in

road construction, paving machines are also used for the construction of aircraft taxi-ways.

The three main concrete pavement types (**Figure 19.5**) differ in terms of their construction and application, and these will be discussed in the following.

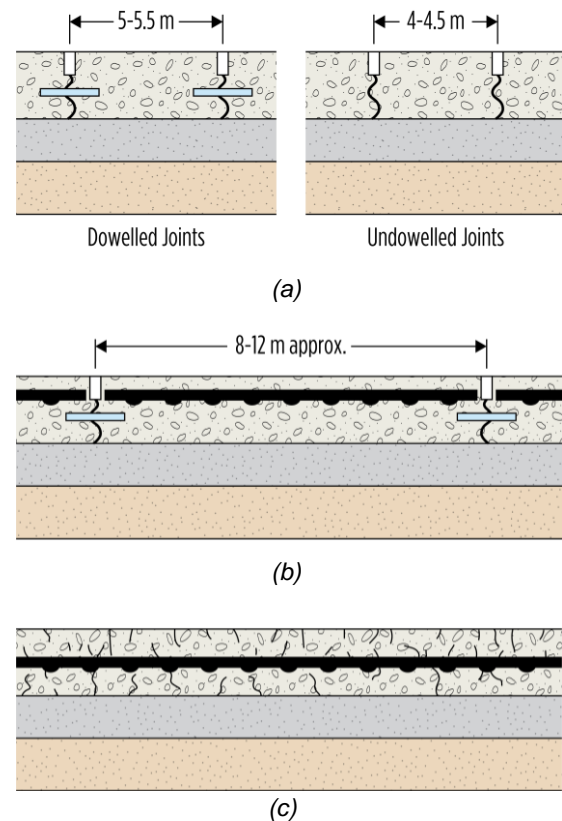

Figure 19.5 – (a) PCP; (b) JCRP; (c) CRCP

Plain Jointed Concrete Pavement (PCP) – This type of pavement can be applied to roads but is also able to be applied to airport and industrial pavements. Pavement thickness can vary between 150 mm and 300 mm depending on the load conditions expected. Joints are provided for in the pavement design, with typically ‘square’ slabs being created – the dimensions of each slab being dependent on factors that include the slab thickness, the type of aggregate and the joint type. Joint spacings vary from about 4 m up to 7 m, depending on the slab design and dimensions. Joints may be dowelled or not – with un-dowelled joints relying on aggregate interlock for load transfer, while dowelled joints (typically using 300 mm dowels) provide vertical load transfer from one ‘slab’ to the other (refer to Part I and Part V, Section 17 of this Guide for more information). The joint

system protects the slab from unwanted cracking due to drying shrinkage. The joints are provided to a depth of about one-quarter to one-third the depth of the slab, while the dowels are generally located at one-half the depth of the slab. The pavement usually sits on a sub-base which may be a lean concrete or other stabilised material. As with all pavements, preparation of the sub-grade is also a strong determinant of the ultimate performance of the pavement.

Jointed Reinforced Concrete Pavement (JRCP) – This type of pavement is not now widely used but may be applied where high levels of load concentration are expected. Where used it provides control over mid-slab transverse cracking and allows much longer distances (8-12 m) between joints to be used. With the higher levels of expected drying shrinkage, dowels are necessary at each transverse joint to transfer vertical shear forces from slab to slab and to reduce load on the sub-base.

Continuously Reinforced Concrete Pavement (CRCP) – This type of pavement is used in heavily-trafficked environments where access for maintenance is limited. No joints are used in the construction of these pavements, and reinforcement is provided through the full length of the pavement – this reinforcement being held in place by transverse bars (**Figure 19.6**). The pavement does crack – with the distance between cracks (typically 1-2 m) being determined by the longitudinal reinforcement – though the cracks are sufficiently fine to not cause issues for the quality of ‘ride’ nor to allow aggressive materials to penetrate the concrete and attack the steel reinforcing. These pavements may be covered by a thin concrete or asphalt wearing course. The high proportion of steel in this form of pavement construction means higher construction costs, but these costs are offset by low ongoing maintenance costs.

In each type of paving, the requirements for the actual concrete used are similar. The concrete is supplied usually as a low (20-40 mm) slump material – often produced in dedicated wet-mix plants using a split drum mixer. These mixers are able to provide the high volumes required to keep the paving machine mobile and they tend

to produce concrete with more consistent quality – particularly in relation to concrete slump. Inconsistencies in supply and quality are both contributors to variable ride performance of the concrete pavement – a criterion that is an important determinant of pavement quality. Managing concrete heat of hydration and concrete temperature also provides more consistency in the final cracking pattern and spacing that is achieved. Delivery of the low-slump concrete to the paver is often carried out using tippers – particularly where there is a site plant within a relatively short distance of the paving operation. Segregation of the low-slump mixes is not typically an issue over these short conveying distances (**Figure 19.7**).



Figure 19.6 – Paving Machine and a CRCP Pavement

A non-erodible base layer is important to the success of CRCP and sometimes asphaltic concrete is used. The asphaltic material provides friction which enables a good cracking pattern to develop. It also provides enduring protection beneath the CRCP.

The application of laser and GPS technologies has improved the accuracy of pavement heights and alignments compared to the wire and ‘string-line’ systems that were used decades ago. The precision and continuity of paving that these provide also assists in improving the ‘ride’ quality.

While there is no debate about the cost-effectiveness of concrete road pavements from an economic perspective (see CCAA Marketing Sheet, March 2018) when compared with other common alternatives, it is also clear that without

some surface treatment(s) concrete roads are noisier than asphalt pavements. Treatments like 'diamond grinding' to lower noise levels and

the use of surface coatings (like open-graded asphalt) have been used in some situations to reduce road noise to acceptable levels.

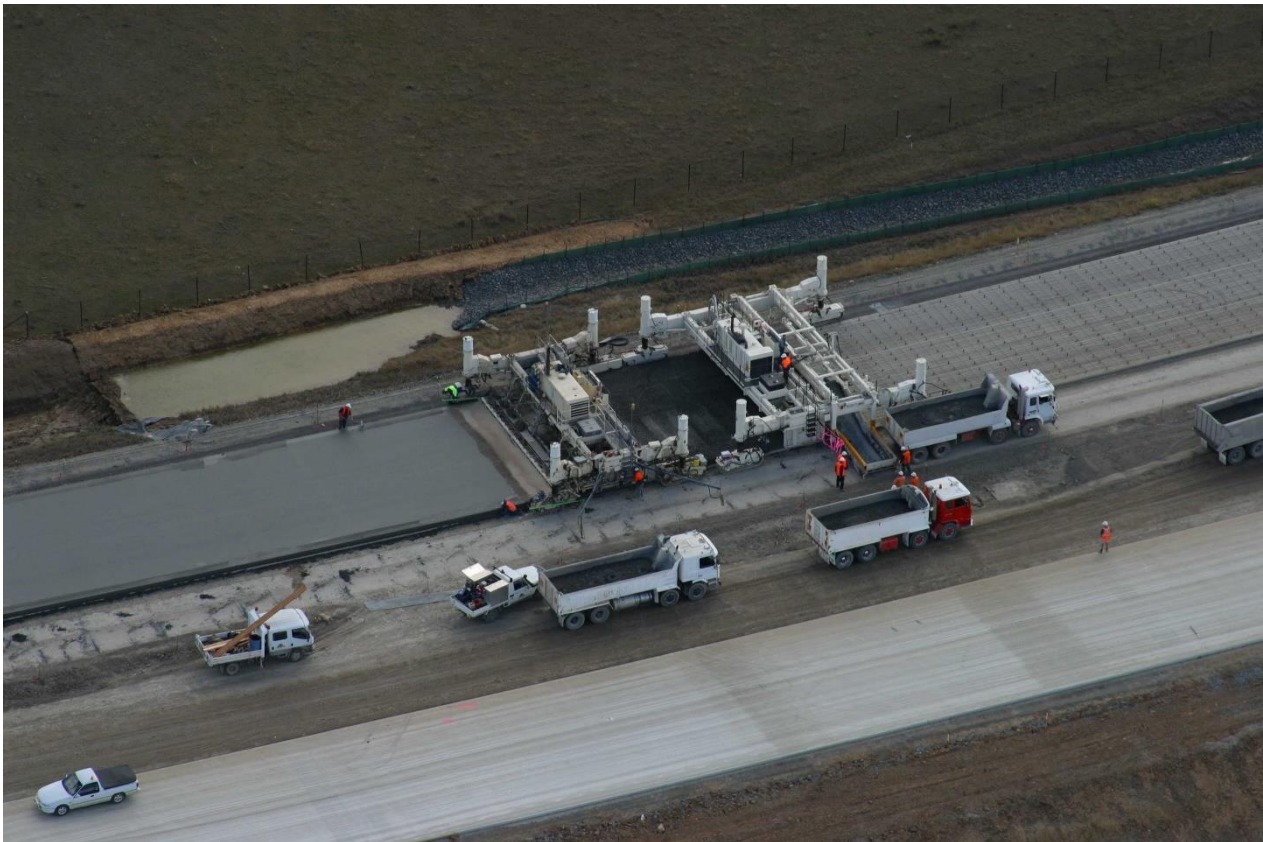

Figure 19.7 – Concrete Supply by Tipper to a Paving Machine

3.3 KERB PRODUCTION

The importance of kerb is often understated or misunderstood. Kerb serves a number of functions related to safety and engineering function of roads including (a) directing stormwater to drains, (b) providing a clear border between the paved surface and adjacent areas (e.g. paths), (c) acting as transition areas, and (d) helping to minimise deflection of the pavement surface. Many years ago, kerb was hand-placed, but is now generally machine-placed using dedicated kerb machines that effectively slip-form (or extrude) the kerb (**Figure 19.8**).

3.4 KERB MIX SPECIFICATION

An Australian Standard (AS 2876 'Concrete kerbs and channels') provides guidance in relation to concrete quality and performance.

The Australian Standard defines the mix to be a special class concrete as it is not specified by a standard compressive strength. The Standard sets minimum cement contents – these dependent on the nature of the adjacent road (**Table 19.1**). The kerb concrete as tested by the supplier (to AS 1012) will be fully compacted in accordance with AS 1012 and therefore produce a compressive strength on testing that is higher than levels that will be achieved in the kerb as placed.

The requirements for kerb concrete relate to its ability to (a) be able to be slip-formed and (b) achieve adequate strength performance in place. Kerb must be able to be formed through the kerb machine and retain its formed shape without formwork. This requires a stiff, low water content mix – one that usually has a specified maximum aggregate size of 10 mm (and sometimes 7 mm or 5 mm) – and is produced with a slump of 10 mm \pm 5 mm. The

Standard allows workability to be modified, noting ‘water addition on site should be adjusted by the person in charge of placement’. Compaction with these stiff mixes can be problematic and AS 2876 requires that if cored, the placed kerb should have a density of not less than 95% of that achievable with the batched concrete. As kerb is generally coated immediately after ‘extrusion’ with a cement-based slurry, it is possible that any compaction problems will not be easily detected.

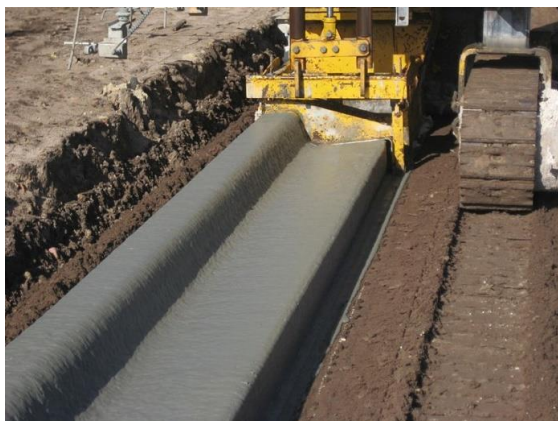

Figure 19.8 – Kerb Construction^{19.3}

Table 19.1 – Minimum Cement Contents for Kerb Mix

Class of Road	Minimum Cement (kg/m ³)
Local Roads	240
Collector Roads	280
Main Roads	320

NOTE: Maximum aggregate size is 20 mm.

The quality of concrete kerb is dependent on a couple of key items namely (a) the machine and the experience/competence of the operator, and (b) the quality of the sub-base or sub-grade. If the surface on which the kerb is placed has not been wetted down prior to placement then it is possible that it may absorb water from the dry kerb-mix which may lead to problems (e.g. achieving compaction). Some contractors prefer to place the kerb concrete in a dry state as they are able to achieve more lineal metres of kerb with less concrete – which is easier to do on downhill runs.

(NOTE: Some specifications require that any coring of kerb be carried out on locations in the kerb where there is the steepest incline.)

As is the case with road paving, the advent of laser and GPS technologies and their use on kerb machines has led to more accurate placement of kerb.

3.5 BARRIER WALLS

Barrier walls and similar cast-in-place structures (e.g. V-drains, mine walls, feedlot troughs) can be effectively produced using slip-forming in an effectively continuous process producing elements with no joints – these replacing numbers of discrete elements which would otherwise need to be transported to site. A wide variety of moulds is available to produce a range of structures.

The most common of these structures is the road barrier (or jersey barrier) which are now a common feature on multi-lane roads (**Figure 19.9**). Similar structures can also be made to separate roads from tunnel walls in an effective way. The concrete requirements for the production of barrier walls etc are similar to those for other slip-forming processes. Reinforcing steel can also be incorporated in these structures.



Figure 19.9 – Barrier Wall Under Construction^{19.4}

Once again, the use of laser and GPS technologies has led to more precise and accurate positioning of barrier walls in road construction in particular.

3.6 BARRIER WALL CONCRETE MIX SPECIFICATION

Like kerb mix concrete, the barrier wall concrete mix design specification is dependent on both the machine being used for placement and the specifying authority. The finish of the formed concrete surface and ability to retain its formed shape after leaving the machine forms are crucial even though some manual finishing is generally applied to the surface.

Some common specification requirements for the concrete are:

- A specified characteristic compressive strength at 28 days (typically 32 MPa or 40 MPa);
- The concrete mix is normally specified as having a 20 mm maximum size aggregate;
- The slump of the concrete is critical to retaining its form after slip-forming. Typically, the mix will be specified as having a target slump between 40 mm and 80 mm depending on the machine used;
- The concrete may be specified as containing fibres (normally synthetic) with the aim of improving the barriers' impact resistance;
- The concrete is generally specified with a target air content with tight limits on its variability. The target varies between 4.0% air and 4.5% air (with a minimum tested value of 3.5% and maximum of 5.0% in most cases).

The entrained air aids the ability of the concrete to hold form at the specified slump. The tight limits on air content and the requirements to hold form may limit the use of larger quantities of fly ash in these mix designs.

4 RELEVANT AUSTRALIAN STANDARDS

- 1) AS 1012 – *Methods of testing concrete*
- 2) AS 1379 – *Specification and supply of concrete*

- 3) AS 2876 – *Concrete kerbs and channels*
- 4) AS 3610.1 – *Formwork for concrete, Part 1: Specifications*

5 OTHER REFERENCES

- 1) Fossa, KT; Kriener, A; and Moksnes, J., '*Slipforming of advanced concrete structures*', in '*Tailor Made Concrete Structures*', Walraven and Stoelhorst (Eds.), Taylor and Francis Group, London (2008), ISBN 978 0 415 47535 8
 - 2) CCAA, '*Guide to Off-Form Concrete Finishes*', CCAA T57 (2006)
 - 3) CCAA, Briefing 15, '*Sustainable Concrete Roads*' (October 2010)
 - 4) CCAA Marketing Sheet, '*Concrete Roads – better value across the life of a project*' (March 2018)
 - 5) Safe Work Australia, '*Guide to Slip, Jump and Travelling Formwork Systems*' (July 2014), www.swa.gov.au
-

End Notes:

19.1 Photo adopted from '*Off shore oil platform (of Condeep type) under construction in Norway*', by Bluemoose, licensed under the Creative Commons Attribution-Share Alike 3.0 Unported license,
https://commons.wikimedia.org/wiki/File:Oil_platform_Norway.jpg

19.2 Photo adopted from '*Slipform Bitschnau Silo*', by Bitschnau, licensed under the Creative Commons Attribution-Share Alike 4.0 International license,
https://commons.wikimedia.org/wiki/File:Gleitschalung_Bitschnau_Kohlesilo_L%C3%BCnen.jpg

19.3 Photo adopted from '*A curb being poured for the Poinciana Parkway, along Kinney Harmon Road, near Loughman, Florida*', by Osceola County Expressway Authority, licensed under Public Domain license,
https://commons.wikimedia.org/wiki/File:Curb_pour_for_Poinciana_Parkway.jpg

19.4 Photo adopted from '*concrete step barrier M1 motorway UK*', by Pushcreativity, licensed under the Creative Commons Attribution-Share Alike 3.0 Unported licence,
https://commons.wikimedia.org/wiki/File:Concrete_step_barrier_M1.jpg

This Section discusses precast concrete – a very broad topic. The variety in just the structural applications of precast is quite extensive and includes bridge beams, wall panels, precast columns, piling, culverts, road barriers, tanks, retaining walls, pipes, paving slabs, stormwater management devices, manholes and many others.

CONTENTS

1. HISTORY	3	7.5 PREFABRICATION AND CASTING	20
2. MANUFACTURE OF PRECAST CONCRETE	4	7.6 HANDLING, STORAGE AND TRANSPORTATION.....	20
2.1 GENERAL	4	7.7 ERECTION.....	21
2.2 FACTORY PRODUCTION OF PRECAST.....	4	7.8 CONNECTION INTO THE FINAL STRUCTURE	21
2.3 TILT-UP PRODUCTION.....	6	8 PRECAST CONCRETE AND THE ENVIRONMENT.....	22
3. STRUCTURAL PRECAST CONCRETE..	7	9 REFERENCES	22
3.1 GENERAL	7	10 RELEVANT AUSTRALIAN STANDARDS	22
3.2 BEAM AND GIRDER TYPES	8	11 OTHER REFERENCES	23
3.3 PRECAST COLUMNS	10		
3.4 WALL PANELS.....	10		
4. ARCHITECTURAL PRECAST CONCRETE	12		
4.1 GENERAL	12		
4.2 EXPOSED AGGREGATE FINISHES	13		
4.3 OFF-FORM FINISHES.....	14		
4.4 APPLIED FINISHES	14		
5 HOLLOWCORE	16		
5.1 GENERAL	16		
5.2 HOLLOWCORE WALL PANELS....	16		
5.3 HOLLOWCORE FLOORING UNITS	16		
6 OTHER PRECAST PRODUCTS	18		
7 SAFETY DURING THE TRANSPORT AND USE OF PRECAST CONCRETE ELEMENTS.....	18		
7.1 GENERAL	18		
7.2 DESIGN OF PRECAST CONCRETE ELEMENTS	19		
7.3 STRUCTURAL DESIGN	19		
7.4 DESIGN FOR HANDLING, STORAGE AND TRANSPORT	20		

In terms of broad categories, precast is probably best separated into three main areas – structural precast, architectural precast and hollow-core. This categorisation still leaves products like concrete pipes which arguably sit outside the three broad, general categories. By the simplest definition, precast concrete elements are ones which are cast in positions or locations other than where they reside in the final structure. In practical terms this means that they are cast either in a factory or in a yard near (ideally) to where they will be used. This also means that the precast element needs to be moved to the actual construction site and then lifted into place by a crane or some other system. This method of construction has both benefits and risks, and these will be described in some detail in appropriate parts of the discussions following. There is some overlap between this section and other sections in this Guide document and these will be highlighted in the various discussions. Without doubt, there has been (and is) a desire in building construction to reduce costs and to de-clutter construction sites to improve efficiency and safety and importantly, environmental performance. Precast concrete contributes to

these aims and will (arguably) continue to grow in importance as a concrete construction method of choice for these and other reasons.

1. HISTORY

Precast concrete use arguably began with the Romans. They used concrete widely throughout Europe, and in some cases, this involved them casting concrete into moulds for the construction of aqueducts, culverts and tunnels. It is generally considered that the first use of a modern 'precast' concrete system may have been by W.H. Lascelles in the UK in about 1875, who introduced a new and innovative housing system [1]. Australia was an early adopter of all things concrete, including precast concrete. The history of Australia's early precast concrete use is described in the NPCAA's *'Precast Concrete Handbook'* [2]. Some of these early and developmental uses included:

- In 1904 – the Bradley's Head lighthouse (Sydney) used precast piles to support four precast shell sections that were filled with mass concrete. It is still in use today (**Figure 20.1**);
- In 1908 – a fully-precast trestle wall system was built at Miller's Point Wharf (Sydney) (**Figure 20.2**);
- In 1910 – centrifugal-spun reinforced concrete pipe was invented by W.R and E.J Hume;
- In 1910 – precast concrete was used in the construction of the Denny Lascelles Austin Wool Store in Geelong;
- Between 1917 and 1932 – the NSW railways department built about 145 railway stations and other buildings using precast;
- In 1946 – Monier (a company previously formed under another name) used hollow precast panels (the Monocrete system) for the construction of houses, schools and other buildings;
- In 1952 – a precast, post-tensioned frame was used for the construction of the Warragamba Ice Tower;
- Throughout Australia, names like Monier, Humes and Rocla were

expanding the use of precast concrete in a wide range of applications.

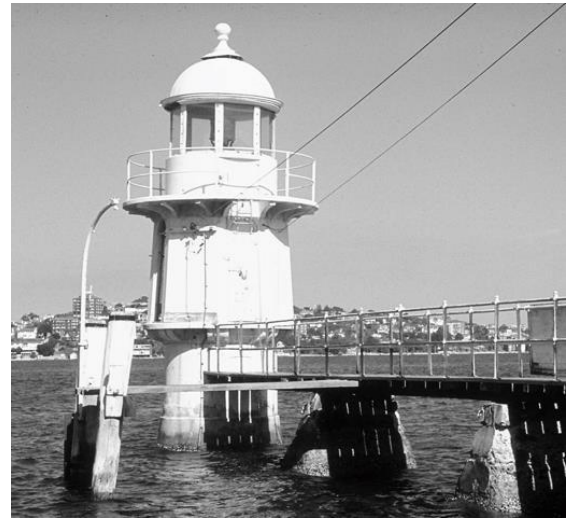

Figure 20.1 – Bradley's Head Lighthouse, built in 1904^{20.1}

After the early forays into general precast concrete construction, precast entered the market as a component of housing and large commercial and residential buildings from the 1960's and 1970's – depending on which State being considered. The use of precast concrete panels in the iconic Sydney Opera House (completed in 1973) provided an example of its versatility and architectural applicability. The huge subsequent expansion of architectural applications and the advent of hollow-core

systems have further enhanced the reputation and scope of precast concrete applications.

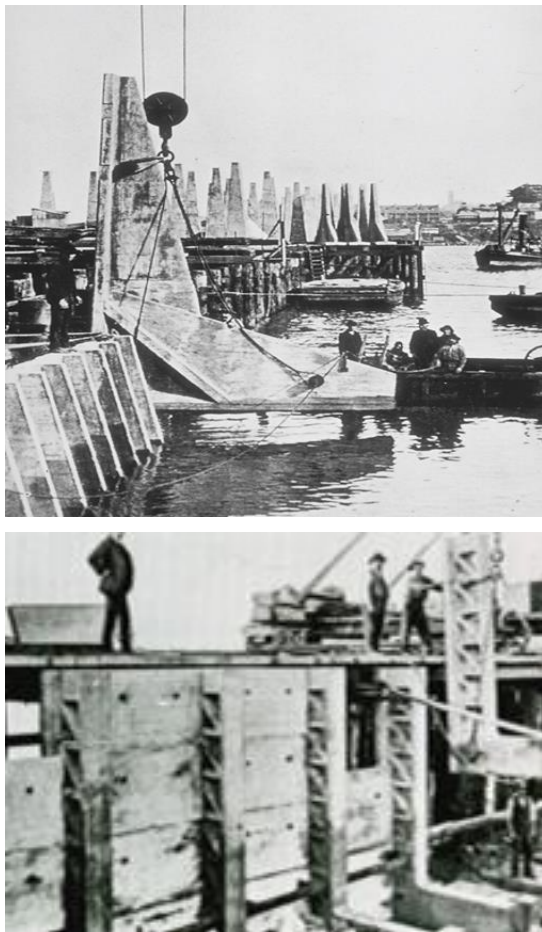

Figure 20.2 – Millers Point Wharf, built in 1908

2. MANUFACTURE OF PRECAST CONCRETE

2.1 GENERAL

Precast concrete elements are, effectively and by definition, elements that are manufactured remotely from their final position in a structure. In some cases, the elements (e.g. bridge beams) may be produced hundreds of kilometres from their final location, while in other cases (e.g. tilt-up panels) they may be cast only metres from their final destination. While these are broadly similar situations, in practice they reflect quite different circumstances and require different approaches. The discussion below aims to provide an overview of the important topics involved in manufacturing and using precast concrete. It is important to note that precast concrete applications are not limited to any

single element of construction but can be applied in an integrated manner (**Figure 20.3**) to create highly robust structures for most building applications. The variety of potential end-uses of precast concrete are such that it is difficult to adequately cover them all in a single document.

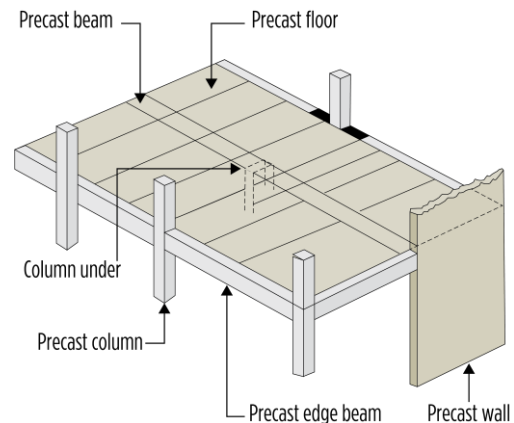

Figure 20.3 – Building Structure using Integrated Precast Elements

2.2 FACTORY PRODUCTION OF PRECAST

The factory production of any item allows for much higher levels of control over production than are able to be achieved 'on-site'. It also allows for a much wider range of production options – options that can be optimised depending on the type and number of elements being produced. In planning for the production of precast concrete, consideration needs to be given to things like (a) the size of the element(s), (b) the required rate of production (e.g. this differs for railway sleepers and bridge beams), (c) the availability of (and need for) steam curing, (d) reinforcement requirements, and (e) the need for prestressing. These issues are also affected by (a) the size, layout and location of the factory, (b) the skill levels in the workforce (for both design and concrete placing and finishing), (c) the level of automation available, and (d) the availability of concrete supply (e.g. capacity of in-house production or availability and cost of external supply). The manufacturing of precast concrete elements is a highly competitive market and a strongly regulated one if attempting to supply to Government agencies.

Good planning, good management and a high level of technical skill are fundamental to success in this industry.

The concrete mix used is typically intended to achieve high strengths, often at least 65 MPa. While ideally (to achieve early and rapid strength gain) cement-only mixes would be used, concerns about durability (particularly ASR), heat of hydration and (more recently) environmental issues means that the use of SCM's is not only routine, but is mandated in some cases. While this has some implications for the rate of strength gain, there are benefits to be had in terms of improved workability, however this is less critical with the advent of modern admixtures – most particularly the use of PCE-based HRWR and MRWR admixtures to produce flowing concrete with low W/C ratios. Increasingly, flowing concrete is used in precast manufacture, and its importance has grown due to the need to overcome problems related to the noise associated with compaction of concrete as well as issues related to congestion in highly reinforced elements and also to ensure the high levels of compaction needed to achieve (a) required strength performance and (b) high levels of durability.

To increase the rate of strength gain steam curing is often used. Steam curing, if properly managed, produces concrete strength sufficient to permit daily production turnaround to be achieved without (a) unnecessary damage to the concrete element and (b) increasing safety risks when lifting the element. Steam curing is applied in a defined sequence that must be observed to achieve optimum strength performance. By its very nature, steam curing results in lower 28-day strength of the concrete than that achievable when curing at ambient temperatures using the same concrete mix – although the amount of strength loss can be minimised by managing the steam curing regime.

Steam curing is carried out as a four-phase operation. The four phases are known as (1) the delay or 'preset' period, (2) the temperature-rise period, (3) the steaming period (which includes 'soaking' at maximum temperature), and (4) the cooling period. The delay period is important – without it, final

concrete strengths can be severely compromised. The extent of the delay period is dependent on a number of factors including the size and shape of the element, the cement content of the concrete mix and the type of cement being used. The temperature-rise period also needs to be managed carefully – with larger elements requiring slower heating to prevent large temperature gradients (and resultant stresses) developing in the element. Typically, the rate of rise is about $20^{\circ}\text{C} \pm 5^{\circ}\text{C}$ per hour. If the temperature rate of rise is too great, then there is potential for localised (surface and test specimen) over-heating and this can affect the 28-day strength. For both technical and economic reasons, a balance needs to be achieved between peak temperature and cycle time. High temperatures ($>70^{\circ}\text{C}$) are also associated with the potential development of Delayed Ettringite Formation (DEF) which is an expansive reaction that can occur in hardened concrete and which can result in severe cracking at later ages. The steaming period is typically maintained for periods in the order of 12 hours. The last phase of the steam curing cycle is the cooling phase. Controlled cooling is more critical for larger elements as thermal cracking can occur with poor control. For some large elements covers are required after stripping until (nearly) ambient temperatures are reached in order to prevent thermal cracking. After precast elements are cooled, they may be wet cured to improve/maximise strength performance – though this is not routinely done.

NOTE: *To monitor or check strength gain performance the concept of 'maturity' is often used. A 'maturity' value is calculated as the product of temperature \times time (i.e. $^{\circ}\text{C} \times \text{hours}$) and strength performance for a given mix and curing chamber can be calibrated against 'maturity'. Similarly, the effect on strength performance of changes to elements (temperature and time) of the steaming phases can be assessed.*

Formwork for precast varies with the nature of the end-product. In a factory environment where standardised elements are produced, steel formwork is used to allow repeated use of the forms which provides cost effectiveness. Where beams or columns specific to a particular building design are being cast, the

formwork may be for one-off use and in this case, timber is more likely to be used to construct formwork as it is of low cost and more readily able to be purpose-built.

Many precast items are also prestressed – a process that is relatively easy to carry out in a ‘factory’ environment. Precast railway sleepers are invariably pre-tensioned (see Part I ‘Principles of Plain, Reinforced, Pre-stressed and Fibre Reinforced Concrete’ in this Guide) and almost always steam-cured. They are typically de-tensioned in a controlled manner after overnight steaming – provided strength test results on cylinders subjected to the same curing regime meet quality requirements. Sleepers are routinely produced in high-throughput systems and being highly standardised items, are eminently suitable for factory precast production.

(NOTE: In some modern plants, steam curing for railway sleeper production is no longer practised as some modern concrete mixes are able to achieve required strengths in a reasonable time without using external heating.)

In a factory production environment, there is an expectation from engineers and end-users that high levels of product quality will be achieved. To consistently achieve high quality there needs to be a high level of attention to detail. Between castings, moulds must be checked for damage and rigorously cleaned to ensure finish quality is high. The dimensions of these highly engineered elements need to be checked before each pour, including checks on adequacy and placement of reinforcing. Tendons need to be properly tensioned and de-tensioned, and in the correct order. Concrete mixes need to be tested and strength performance monitored at the end of the construction cycle to ensure that the element is able to be safely lifted. Concrete workability needs to be suitable for the element design so that the concrete is able to be placed (around reinforcement and into tight corners) and compacted to achieve the required finish and strength and durability performance. For major projects where precast elements need to be properly sequenced into the build, a suitable identification system must be maintained so that elements are delivered to the job in the correct order for erection.

2.3 TILT-UP PRODUCTION

Tilt-up, which began in the USA, was first introduced into Australia in the 1960’s, but did not gain prominence until about the 1980’s. Its use is mainly for panels used in low-rise structures and was initially primarily used in industrial situations. This has now changed and tilt-up is now being used in new markets for the construction of residential housing, for schools and in a range of non-commercial applications.

Tilt-up panels are usually cast ‘on-site’ or adjacent to their final location and consequently do not need to be transported from a factory. They are lifted into place by crane, and this can be done in an efficient way by casting multiple panels at the site and erecting these simultaneously while the crane is available. Panels do not need to be solid concrete facades but can include allowances and rebates for windows and doors as required in the final structure.

A tilt-up panel or panels can be cast onto a base slab, singly or stacked in layers, with the top surface of each layer being coated with a bond-breaker (sometimes these include a curing compound) to allow removal of the upper panel when required. Panel quality is important, especially where multi-storey structures are involved. Panels need to be accurately sized and square and tight manufacturing and building tolerances apply. Panel finish is also important. Even for industrial buildings, variable panel colours and textures and mottled finishes create complaints. Once stood in the final structure even small variations in colour and finish within and between panels become very obvious. The colour variations will often diminish over time as the concrete ages, but when the building is first erected, colour contrasts are immediately apparent. While arguably one of the advantages of using tilt-up is that it does not require a factory set-up and also does not require highly skilled workers, the quality expectations in terms of both concrete performance and appearance mean that poor quality work will generally not be accepted.

If decorative or architectural requirements exist there are a number of techniques used to

improve panel appearance (see sub-section 4). Exposed aggregate, colour and texture contrasts and grooves and shallow recesses can be used to enhance surfaces or break up monotonous (grey) concrete surfaces. These effects can be achieved in several ways – by using coloured concrete; by applying various texturing processes; and by placing strips on the slabs on which the panel is being cast to provide shallow recesses to break up the ‘plain concrete’ facade.

When designing and building with tilt-up, the location and detailing of services and joints is of great importance in ensuring that both the buildability and effectiveness of the structure are maximised. Joint widths must allow movement due to thermal changes and be sufficient to cater for erection tolerances. Reasonable widths between panels are typically 15-25 mm. Sealants are used to fill the joint and to allow for movement in the structure. The sealants are of limited depth and are bonded only to the two sides of the joint, which necessitates a clean, well compacted concrete surface on each side. At the corners of tilt-up buildings special care is required. ‘Over-sail’ joints or mitred joints can be used, but mitred joints require extra care during construction as they are more prone to breakage during lifting and placing of the panels (**Figure 20.4**). Erection tolerances can be absorbed in the joint gaps and the design joint width must be sufficient to absorb them.

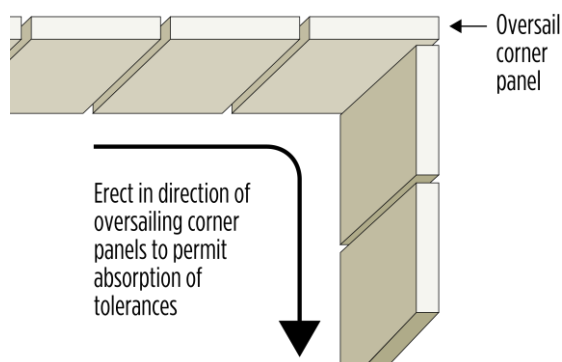

Figure 20.4 – Over-sail Joint used in Tilt-up Panel Construction

As noted, when panels are cast, either singularly or in multiples, a bond-breaker is used to allow individual panels to be separated and erected once the required strength has been obtained. These bond-breakers not only

allow concrete panels to be separated but will also prevent coatings (e.g. paint or render) from adhering to the surface. If such coatings are required, then any residual bond-breaker must be removed before the coating is applied. If not, the coating will generally just ‘sheet-off’ in due course.

Panels will invariably have ‘lifting lugs’ inserted in them to allow them to be moved into final position by crane. For aesthetic reasons these lugs will need to be removed or coated/covered in the final structure.

Panel lifting is a critical activity and it is necessary for the panel to be of sufficient strength for the lift to occur safely. The lift may need to occur before 28-day strengths have been achieved and if so, consideration must be given to the 7-day minimum strength requirements of AS 1379. If these strengths are insufficient then a Special Class concrete with a specified 3-day or 7-day strength may be required, as may project testing to confirm that the required strength has been achieved before attempting to lift the panel.

Concrete used in these panels must meet the durability requirements described in AS 3600. Their thickness also needs to be such that appropriate fire-rating requirements are met. Insulation can also be provided to accommodate concerns or issues about thermal and/or acoustic performance. Insulation may be used to overcome any concerns about condensation within the building.

3. STRUCTURAL PRECAST CONCRETE

3.1 GENERAL

Structural precast concrete includes elements like beams and columns for bridge and building construction, bridge deck slabs, wall panels, retaining walls, lift wells, stair wells and stair units and others. In many of these applications, the element would previously have been cast on-site with the need for extensive formwork, large labour force, delays while concrete gained strength (which inhibits the activity of following trades) and increased safety risks

due to (a) the higher level of activity on the job site and (b) clutter due to the presence of formwork and falsework.

Using factory-made precast elements (a) allows greater accuracy levels in the element to be achieved, (b) provides high levels of certainty about concrete quality, (c) results in fewer site delays as the precast element can be delivered to site when actually required without concerns about weather delays etc., and (d) lower safety risks. There are also indirect benefits through lower levels of waste and less raw material movement on site. In some cases, stronger (prestressed) precast elements allow the use of thinner elements which results in less concrete being used and therefore overall environmental performance is improved through 'dematerialisation'.

There is a wide variety of structural precast elements in use, with the main groups being (a) beams and girders, (b) columns and (c) wall panels. Some of the types of each and their primary uses are discussed in the following.

3.2 BEAM AND GIRDER TYPES

Some of the most common beam and girder types are:

Tee Beams – These beams may be obtained in either single or double-tee configurations and provide a very efficient structural shape (**Figure 20.5**). These beams may be of varying widths but are typically about 2,400 mm wide. The depths of the beams vary but they are typically about 600-1,000 mm for single and 400-700 mm for double tees. They are cast in long pre-tensioning beds and the units themselves may be produced in a range of lengths – from 12-24 m for double-tees and 15-30 m for single tees. When pre-tensioning these beams with tendons that run the full length of the beam problems with over-stressing can occur and it is usually necessary to de-bond the tendons partially to reduce stress levels. Within the structure the beams are typically topped with a nominal 32 MPa reinforced screed to provide the final floor finish (**Figure 20.5**).

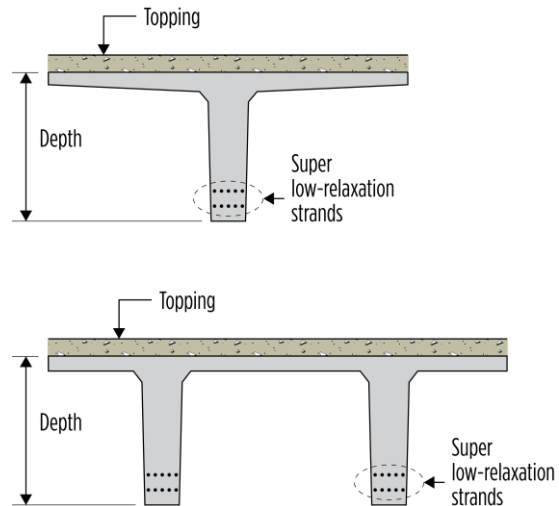

Figure 20.5 – Single and Double Tee Beams with Cast In-situ Concrete Topping

Main Beams – These beams are major structural elements and their design varies with the needs of the structure. Typical types are rectangular beams, Tee-beams, L- (or spandrel) beams and ledger (or inverted Tee) beams (**Figure 20.6**). The beams may be reinforced or pre-tensioned. The spandrel and ledger beams may be used to span clear sections and to support flooring or transverse beams.

Beam Shells – These are long, U-shaped members that contain the main beam reinforcement and that can also be used to support floor planks. They usually sit on a column and become integral with the planks and the topping concrete through the reinforcement detailing when the floor is finished (**Figure 20.7**).

Bulb Tee Beams – These are beams used in bridge construction. These prestressed beams have span widths that are typically 1,200 mm and variable depths from 1,200-1,700 mm and are used in the construction of long span (18-40 m) structures. They are topped with about 200 mm thick, high strength (typically 40 MPa) concrete to form the bridge deck.

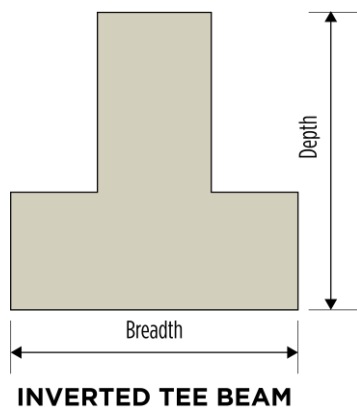
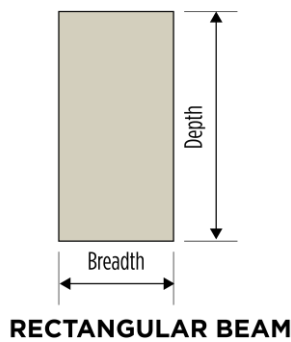
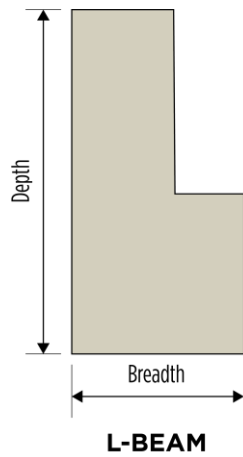
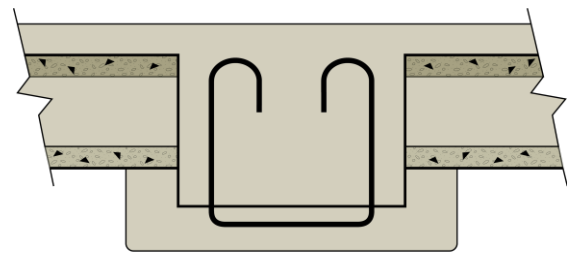

Figure 20.6 – Common Precast Concrete Beam Shapes

Super-Tee Box Girders – These are prestressed, precast girders used for bridge construction that come in two forms – ‘open top’ and ‘closed top’. Beam widths vary from 1,800-2,400 mm and depths for both types vary from about 750 mm to 1,800 mm. They are useful for spans up to about 40 m. Concrete used for the deck should be high quality (e.g.

40 MPa) and be well placed and cured, with depths typically of 150-200 mm (Figure 20.8).



BEAM SHELL

Figure 20.7 – Beam Shell – Integral with Floor Panels and Topping

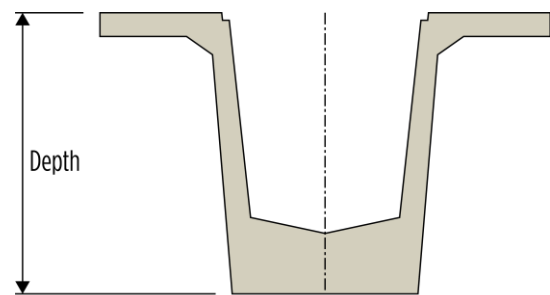

SUPER T-BEAM

(a)



(b)

Figure 20.8 – Super Tee-Girder: (a) Section; (b) In-Situ

I-Girders and Broad-Flange Girders – These are similar girder types, with the broad-flange type being effectively I-girders with extended flanges that when assembled have about a 30 mm space between the girders. They are prestressed girders using nominal 50 MPa concrete for construction. Both are used in bridge construction for bridges with up to a 30 m span, and where the concrete deck is

typically about 200 mm of nominal 40 MPa concrete (**Figure 20.9**).

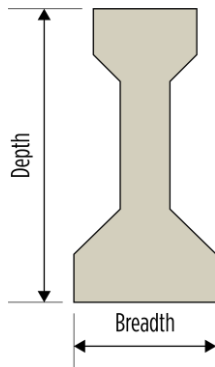

Figure 20.9 – I-Girder

3.3 PRECAST COLUMNS

Precast columns may be used in buildings constructed from precast elements or may also be used where in-situ cast concrete is being used for floors. The columns are usually cast in the maximum length able to be handled when considering (a) transport to the job, and (b) site crane capacity. Prestressing is used where appropriate to cope with transverse loads that may be encountered in the structure. If only axial loads are expected, then normal reinforcing can be used. Where additional columns are required to accommodate the height of the building, these columns are spliced to the lower column(s). Splicing is done at locations where there is minimal bending likely – this typically being between floors. These columns have the advantages of being able to be specifically designed for the building, have assured strength performance and reduce both formwork on site and construction times (**Figure 20.10**).

To anchor the columns to the base of the building several options exist. The most common is a bolted connection to a base plate that is anchored to the floor. A socket connection can also be used, where the column is grouted into a socket located in the building floor. Alternatively, the column can be connected into the base with a dowelled connector – the dowels being grouted into the base and connecting through into the column reinforcement. Splicing of columns is usually

done by grouting in (up to eight) dowels that connect the two columns.



Figure 20.10 – Precast Concrete Columns supporting Structural Beams

3.4 WALL PANELS

Wall panels may be produced as conventional (factory-produced) precast concrete elements (using either reinforced concrete or prestressed concrete), as tilt-up elements (see 2.3) or as hollow-core (see 5.2) panels. The following discussion will describe the general requirements for precast concrete wall panels.

While there are advantages to using precast concrete wall panels of all types, there are also important considerations that need to be understood. As these panels are often load-bearing they need to be properly designed, and where door and window openings are included the design issues are more complex and critical. Allowance must be made in the design for the provision of services (e.g. water and power) to the final structure as retrofitting of these in the building would be problematic. The erection of wall panels is also critically important to ensure the safety of personnel on the construction site (see 7.7). Panels need to be propped until fixed into place, and the proper fixing of panels to adjacent structural elements is fundamental. The panels also need to contain embedded fixtures to allow safe lifting and to allow props to be attached while construction is progressing. These fixtures must be removed, and the area where they were located repaired in the final structure. In addition, the construction site conditions must allow for the movement of the

(large) cranes which are used to stand and align the panels. From an environmental perspective, these (relatively) high strength panels and the construction method leads to them having a high level of 'embodied energy' (see Part X 'Environmental Considerations' in this Guide).

Precast wall panels may be plain or provided with one of a variety of possible decorative surface finishes providing aesthetic/architectural appeal. The application of architectural finishes will be discussed elsewhere (see sub-section 4). Precast may also be used in the manufacture of cladding panels which primarily provide a decorative function (**Figure 20.11**). Regardless of their finish, precast concrete wall panels serve a number of critical functions in building construction.



Figure 20.11 – Precast Cladding Wall Panels

Fire resistance is a key function of wall panels and the panel thickness is a key determinant of the fire rating and performance requirements are prescribed in AS 3600. Panels are usually between 120 mm and 170 mm thick which typically provides either 2-hour or 4-hour fire protection, respectively. In any circumstance, 100 mm thick panels are generally the minimum in order to provide sufficient cover to

reinforcing steel. Not only is the fire rating of the panel itself important, but so too is the contribution of the joints. Where sealants are used, a detailed method of application and their fire rating performance need to be supplied by the sealant provider.

Ideally, panels should be made to the largest dimension that can be transported to site and lifted by an available crane (see 7.4). When panels are located in the structure the normal joint width between precast panels is about 20 mm; with about 35 mm allowed between panels and in-situ concrete elements. Joint sealing is an important aspect for ensuring that the structure is weather-proofed, that any differential movement of adjacent elements does not affect weatherproofing and in some cases, that fire rating requirements are maintained. There are several joint types that are regularly used – as described in the NPCAA publication [3] on 'Joints in Precast Concrete Buildings'. There are a range of sealant types that may be used and these need to have (a) water-proofing capability, (b) the appropriate adhesion characteristics and (c) be able to retain their filling capability in a range of temperature conditions. Sealants must be properly emplaced – typically with a backing rod, and sufficient time must be allowed for them to cure properly. The surface of the concrete where sealants are applied must be clean and free from loose material. Compression-seal joints may be used where the structure does not allow gun-applied sealants to be properly used.

Joints may also be provided using (a) grouting or (b) in-situ concrete. In these cases, the minimum joint spacings between precast elements must be not less than 20 mm and 150 mm, respectively.

Panels provide both structural support and improved thermal performance. From a structural perspective, panels can be designed for use as load-bearing walls and to provide lateral stability in the building. By virtue of their inherent thermal characteristics (e.g. heat capacity) and by incorporating design features to shade the inside of the building they can significantly improve comfort levels and heating and cooling performance of a building – and also provide good sound insulation. The

panels can be designed to include window and door openings and panels can also be designed to carry floor and column loads in a variety of situations (**Figures 20.12, 20.13 and 20.14**).

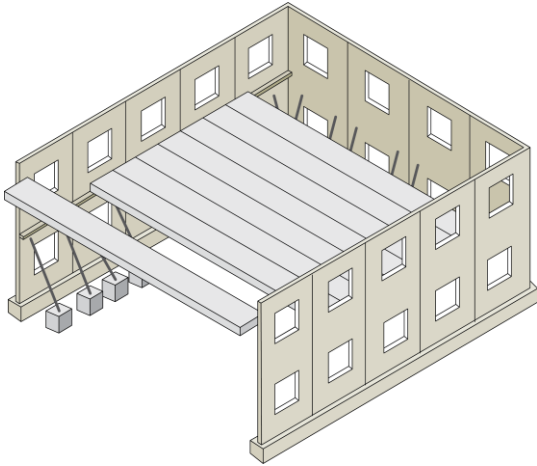

Figure 20.12 – Two-storey Panel Building with Window Openings



Figure 20.13 – Internal Precast Wall Panels – loadbearing walls to support precast flooring

The thermal performance of precast concrete wall panels can lead to concerns about condensation within buildings in certain weather and ambient conditions. To limit concerns about condensation in buildings using precast concrete wall panels, it is common to insulate the internal surface of the walls and also to ensure adequate heating of the building and the provision of ventilation.



Figure 20.14 – Precast Wall for a Lift Shaft and Stair Core

4. ARCHITECTURAL PRECAST CONCRETE

4.1 GENERAL

Architectural precast units typically apply the types of finishes that are common in other concrete types and styles, but their application can be much more obvious through their use in commercial building facades, in panels decorating roadsides and public open spaces and for large public structures like Government buildings, Courthouses and museums. Architectural precast panels have led the movement to replace the 'grey panel' view of concrete construction with the new, colourful and complex textures and designs that typify modern concrete.

Generally, the complexity and consistency of colours, textures and designs that can be achieved with precast are not as readily or consistently able to be achieved with in-situ concrete construction. The manufacture of precast in factory environments provides

higher levels of accuracy and consistency that are generally not able to be achieved on site. The scope of finish types available to be used with concrete are described in detail in the CCAA Guide T57 'Guide to Off-Form Concrete Finishes' and potential problems with managing surface finishes have been described in Section 16 'Control of surface finishes' in this Guide. There are several main methods of achieving architectural finishes with precast concrete and these will be discussed in the following.

In all cases where aesthetic and architectural expectations are involved, it is important that before full-scale production begins, trial panels created in realistic production situations are prepared. Not only do such panels illustrate the quality of finish that should be achieved, they stand as a record of what was/is able to be achieved and should reduce the level of complaint and aggravation that can occur when the 'real' job has been completed. Obviously, the same materials and casting and finishing processes must be used for the trial panels as are being used in the 'real' job. It should be noted that casting in vertical or horizontal positions can alter the orientation of aggregates and alter the appearance of concrete, as can source and proportions of colouring oxides, W/C ratio, type and extent of curing and lastly (and importantly) – time. The appearance of the concrete surface may change as it equilibrates with the local environment. In some cases, efflorescence may also occur.

4.2 EXPOSED AGGREGATE FINISHES

There are a variety of ways that the off-form or finished face of a concrete element can be altered by physically altering the surface quality and texture (**Figure 20.15**). These techniques normally require a high level of skill to ensure they are carried out properly and consistently over the entire visible surface. It should also be noted that coloured concrete may be used with all of the methods below to enhance the appearance of the finished surface.



(a)



(b)

Figure 20.15 – (a) Ribbed Finish using Timber Battens; (b) Acid Etching (top-light; bottom – medium)

Conventional Exposed Aggregate – The aggregate sitting just below the surface of the finished concrete can be partially exposed to create a highly decorative surface – without a major impact on serviceability. This is usually carried out on horizontal surfaces but can, with

care, be carried out on vertical faces. In an alternative approach, the surface of the concrete can be 'seeded' with a decorative aggregate – placed on the surface of the plastic concrete and then rolled into the surface. In the usual method of exposure, the paste is gently washed away from the aggregate, to a depth of about 30% of the depth of the maximum aggregate size. This is carried out immediately prior to the concrete setting. In some cases, a mild retarder is sprayed onto the surface which allows the surface paste to be washed away while the underlying concrete remains unaffected. For precast panels, the washing process may be assisted by a slight tipping of the panel to allow the removed paste and water to flow away from the finished face.

Grit Blasting – This method involves the use of an air-driven blasting medium to erode the surface of the concrete providing a quite gentle, even 'matt' surface. A variety of blasting media are available including glass and copper slag. Care needs to be taken if/when these processes are carried out in the open as they create large amounts of fine dust and it is likely that the crystalline silica content in that dust may be high.

Honing and Polishing – It is possible, with higher strength concrete, to cut away the top few millimetres of the concrete surface using 'polishing' devices to create a polished surface. This is done in multiple stages with quite large machines, which requires that edges and corners be hand-polished to extend the finish across the whole panel surface. The polished surfaces can be used in combination with other surface textures and colours to create a huge range of high-quality, decorative surface effects.

Other Mechanical Methods – Any device or system that can be used to decorate the surface of a precast concrete panel without affecting the structural performance of the panel can be employed to create decorative finishes. Ideally the system should not be too labour intensive and should create a consistent finish. Examples include (1) bush-hammering – the use of an impact device to remove 1-2 mm of the surface to reveal the underlying aggregate, (2) rope finish – where the concrete is cast against a 'rope liner' which is removed

once the concrete hardens, and (3) ribbed finishes – where 'ribs' are laid along the mould to create geometric patterns that break up an otherwise bland concrete surface. Whenever the use of large areas of panel are proposed, the use of artificial joints to break the surface up will both improve the appearance and help to hide any imperfections in the finished surface.

Acid Etching – The use of quite dilute solutions of mineral acids (e.g. hydrochloric acid or phosphoric acid) can be used to remove a thin layer of paste from the concrete surface. This method provides an even finer finish than grit blasting. To control the effect of the acid it is best to wet the surface of the concrete with water before applying the dilute acid solution. The depth of etching is proportional to the strength of the acid solution and the contact time.

4.3 OFF-FORM FINISHES

There is a massive range of options available for achieving bold and exciting off-form finishes. For simple trowelled surfaces, coloured or not, it is very difficult to achieve uniform texture and colour consistency across a large panel. In such situations, it is usually necessary to include indents or some other means of breaking the surface down into smaller sections as noted above. There are however, many options to create textured, off-form surfaces using materials as simple as timber, as well as a variety of form materials (from timber with plastic coatings through to rubber form liners) that may impart highly complex designs onto the concrete surface. When combined with colour and other surface finishes the range of options is as huge as it is decorative (**Figure 20.16**).

4.4 APPLIED FINISHES

There are several types of applied finishes including – coatings (renders and paint) and attached tiles or stone slabs.

Where coatings like render or paint are used, it is important to ensure that the concrete surface is clean and able to accept the coating. If bond breakers or curing compounds have been used in the manufacture of the concrete panel some residues may remain, and these may cause the coating to fall off in sheets relatively soon after application. Cleaning of the concrete surface should always be carried out and a trial application of the coating would provide extra certainty. A significant cost issue with the use of these coatings is the need to maintain or replace them from time to time.



(a)



(b)

Figure 20.16 – Decorative Panels, Effects Created using (a) Timber Forms and (b) Rubber Form Liners

When solid decorative materials like tiles or natural stone facing materials are to be used in

conjunction with precast concrete, it is important that the likely interaction of these materials be understood. It is possible that these non-concrete materials will have different levels of expansion to the base concrete when the structure is exposed to heat and cold, and this will in due course create bond issues between the base concrete and the decorative material. Tiles may be adhered using cement-based adhesives. Where solid decorative facing materials are used a connector may need to be bonded into the concrete and then connected to the facing material, with an insulating layer being provided between the concrete and the facing material to separate them (Figure 20.17).



(a)



(b)

Figure 20.17 – Randomly Shaped Marble Pieces Mechanically fixed to Backing Concrete

5 HOLLOWCORE

5.1 GENERAL

Hollowcore systems are becoming increasingly popular as the construction industry moves more towards off-site construction solutions to replace in-situ construction which brings with it a range of inherent issues. While these issues have been discussed previously, it is worth noting that they include variable concrete element quality, site safety, speed of construction and site congestion. Hollowcore is being applied in two significant areas – concrete wall panels and concrete flooring, and these will be discussed separately below.

5.2 HOLLOWCORE WALL PANELS

Hollowcore wall panels are usually produced in standard panel sizes of either 1,200 mm or 2,400 mm width, though narrower panels can be made by casting smaller panels or saw-cutting larger panels. Wall thicknesses can range from 150 mm to 300 mm and the shape and size of the cores can vary with the manufacturing equipment. Casting beds can be up to 200 m long and working panels are cut to length by saw-cutting. Wall panels can be designed and built for load-bearing or non-load bearing situations. The resultant panels are strong, lightweight units. They can be designed to meet relevant fire and noise rating requirements as well as durability requirements as specified in AS 3600.

Hollowcore wall panels can be produced with a variety of finishes including most of those described in sub-section 4. Exposed aggregate, ribbed and broom finishes are available from some manufacturers, and the panels (in all finishes) are available in a range of colours.

Panel fixing to adjacent building elements is carried out using standard fittings that are widely available. With a now quite long history of use of hollowcore panels these fittings are 'tried and tested'. The fitting types are detailed in the NPCAA 'Hollowcore Walling – Technical Manual' referenced at the end of this Section.

5.3 HOLLOWCORE FLOORING UNITS

Hollowcore flooring is provided primarily as units of varying widths (but typically 1.2 m wide) and they can cover spans of up to 20 m. These units may be referred to as 'planks', 'slabs' or 'panels'. They range from 100 mm to 400 mm in thickness and they are invariably prestressed. The panels are truly 'hollow' – with from 4 to 6 hollows longitudinally – these hollows occupying two-thirds to three-quarters of the panel thickness. The panels are cast on long beds – up to 200 m long – and the working panels are saw-cut to length while on the bed (**Figure 20.18**).



Figure 20.18 – Hollowcore Planks of Varying Thickness

When used for floor construction in large buildings they are usually overlaid with a reinforced slab of cast in-situ concrete to provide a level floor. They can however be simply grouted together along their lengths to form the working floor. The soffit of the panels can be treated in various ways to form a ceiling for the floor below. The panels can be painted, or a texture finish applied; they can be lined with plasterboard or, a hanging ceiling can be affixed to the panels. The hollow cores in the panels can be used as service ducts.

The long spans do not require propping or formwork to support them, and following trades have a lot of space to carry out their work – both beneath the floor or using the new floor as a work platform. When using floor panels, fewer people are required on site and the sites have lower levels of congestion. During construction, the panel production process and

the building construction process can be synchronised so that panels are delivered and emplaced when and as required in what has been described as being like building with a 'meccano set'. The panels can be supported by masonry walls, precast or in-situ concrete walls and beams made of either prestressed concrete or steel (**Figure 20.19**).



Figure 20.19 – Long Span Hollowcore Flooring provides Space during Construction and Use

The panels have a high level of design flexibility and can be designed to accommodate high loads, openings and cantilevers – while meeting durability and noise and fire ratings for a wide range of building types. When determining the most appropriate panel design, a defined process is usually undertaken, with steps similar to the following:

- Initially assess the structural design in terms of columns, wall and beams and load paths;
- From the nature and location of the building assess noise and fire rating requirements and (AS 3600) durability requirements;
- Determine the minimum panel thickness, concrete strength and depth of cover required;
- Taking account of the design and likely deflections, determine span lengths and panel thickness requirements;
- Determine dead and live loads;

- Check the strength capacity of the panels given the span and load conditions;
- Consider the topping requirements (particularly the thickness) to ensure that the camber (due to the prestressing) in the panel is accounted for and that there is sufficient concrete cover to all reinforcement.

There are fairly standard design requirements for the thickness of the panels based on the span length/thickness ratio. The ranges for this ratio are typically 30-35 for floors and 35-40 for roofs, however any situation where the ratio exceeds 30 should be checked to ensure there is adequate vibration stiffness. As a result of the prestressing, the panels have a camber which generally requires the application of a (reinforced) cast in-situ concrete topping to provide a flat floor surface. The degree of camber expected can be calculated based on the design load and the degree of prestress. Excessive camber can be reduced by adding extra prestressing strands. The degree of camber tends to decrease over time due to the combined forces of concrete creep and some loss of prestress.

During manufacture of the panels they are prestressed using multi-strand arrangements. For thinner panels prestressing strand is used in the bottom of the panels, while for thicker panels prestressing strand is placed at the top and bottom of the panel. The concrete strengths used are typically 40-65 MPa, while for the reinforced toppings, 32 MPa or 40 MPa concrete is generally used.

In the building itself, the Hollowcore panel system should be tied to the support structures using grouting or cast in-situ concrete using ties that link to the support beams and/or topping concrete. The panels should be connected by way of grouting to ensure load transfer and to allow the whole structure to act as a monolithic system. Where the panels sit on support structures there may need to be a bearing support in the form of a thin (e.g. 3 mm) neoprene pad or similar to limit damage to the support structure (e.g. for a masonry wall). Penetrations through panels, if large, should be cut in the factory. In some cases, headers

must be included during construction to allow load transfer to adjacent panels. For smaller penetrations that are cut on site, care must be taken that in the process of cutting the penetration, no prestressing strands are cut.

6 OTHER PRECAST PRODUCTS

Other types of precast concrete products commonly available are used in applications such as landscaping and for a wide range of civil engineering structures.

In civil engineering structures, examples of the application of precast concrete include tunnel linings, piling, manholes, culverts, bridges (railway, road and footbridges), septic and sewerage systems, sea walls, desalination plants, marine structures, sports stadiums, crypt systems and many others.

Landscaping applications include retaining walls, bollards, park benches, slabs and steps in parks and playgrounds, wheel-stops and kerbs and other architectural features (Figures 20.20 and 20.21).

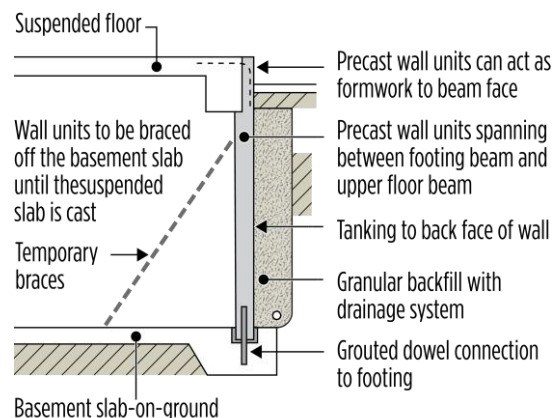

Figure 20.20 – Precast Concrete Retaining Wall Structure

For these applications in particular, it is the combination of several features that makes precast concrete a useful option for planners, designers and architects. These features include strength and durability, wide range of designs possible, consistency of products (due to manufacture in a factory environment and using moulds), wide range of colours and finishes possible and design flexibility through the ability to mould an initially plastic product.



Figure 20.21 – Precast Elements used for Urban Landscaping

7 SAFETY DURING THE TRANSPORT AND USE OF PRECAST CONCRETE ELEMENTS

7.1 GENERAL

A national Code of Practice for the use of precast concrete elements has been prepared by the Australian Government and is referenced at the end of this Section. This code applies to building construction only and not to the use of precast concrete for, for example, bridge beams, pipes and culverts. It is also

noted by the NPCAA that there are aspects of this Code that conflict with other more modern approaches and that this Code is to be re-written. The following provides a general review of safety practices relating to the use of precast concrete elements only.

While the use of precast concrete elements undoubtedly reduces a number of safety concerns at building sites (see Part IX, Section 28 '*Occupational Health and Safety*'), it does however create some specific issues. Precast concrete elements are very heavy and quite large and once delivered to site, need to be craned into position. After being placed in position they need to be stabilised until connection into the final structure occurs. The final structure needs to have sufficient load bearing capability, in both the individual elements and the overall structure, to cope with both live and dead loads that may be experienced by the structure during its life. These serviceability expectations are only able to be met if the design, manufacturing and construction activities are properly undertaken.

Rigorous safety assessments are required at all stages of the design, manufacture, transport and erection of precast concrete elements and the key elements in each area will be described in the following. The basic requirement is that there should be in place a rigorous system or set of systems that are able to (a) identify hazards in all of the stages, (b) eliminate hazards wherever possible, (c) develop control measures to reduce risks from any hazards that are not able to be eliminated, (d) educate and inform people as to the risks, and (e) document all processes, procedures and systems used in risk management.

7.2 DESIGN OF PRECAST CONCRETE ELEMENTS

The broad elements that require consideration during the design phase include (a) provision of adequate documentation including design drawings, site plans, shop drawings and erection documentation, (b) actual structural design, and (c) plans for storage, handling, transport and erection of the elements. Where multiple designers are involved in various parts

of the planning and design then they all need to contribute to the health and safety planning. All relevant documentation should be available at the work sites. Where risks cannot be managed out of the project then documentation should include work instructions to manage remaining risks. If proprietary equipment is being used, then all relevant product information should be included within the project documentation.

Structural design drawings prepared by a qualified engineer need to include all relevant engineering information including critical dimensions, reinforcement detailing, connector locations, concrete specifications, grouting sequences and service locations. These drawings must be properly authorised.

Planning for the actual construction requires plans that describe the locations of each concrete element and the construction sequencing. Site-specific issues that might affect construction including location, traffic issues and the presence of site obstructions must be assessed and documented.

Shop drawings need to be prepared and ultimately signed off by the design engineer. These should include the numbers of elements required; their size and weight; reinforcement requirements; concrete requirements to meet AS 3600 specifications; nature and location of fixing and lifting inserts; any bracing required; propping requirements for each element, and clear identification of each element.

Erection documentation should include every aspect of the erection process. This includes sequencing, bracing and grouting.

7.3 STRUCTURAL DESIGN

Structural design involves the detailed design of the elements, transport and erection processes to ensure that applicable requirements of AS 3850 (Parts 1 and 2) and AS 3600 are met. In a broad sense this requires detailed assessment of manufacturing requirements, erection method(s) and their requirements, likely load expectations and stability of the structure during and after erection.

Particular consideration must be given to joints and jointing methods and materials as well as fixing inserts which should be provided on the shop drawings.

7.4 DESIGN FOR HANDLING, STORAGE AND TRANSPORT

The main considerations requiring assessment in this phase include (a) the size and shape of the elements, (b) how they will be lifted (by edge or face and whether they will be rotated), (c) cast-in fittings, (d) load issues when handling and storing, and (e) additional reinforcement requirements.

The size and shape of the elements determines the difficulty they may present when lifting and handling (e.g. bending and buckling), which requires lifting inserts to be appropriately placed. Lifting inserts need to be in sufficient number, to have sufficient capacity and to be appropriately located and anchored. Concrete strengths also need to be adequate for the lift to occur. Any cast-in fixings need to be suitable and should be standardised across the project to minimise issues.

Structural connections should be adequate to support loads likely to be encountered both during construction and operation of the building. Loading of elements may differ in the erection and operational phases and these need to be considered separately. Impact loads during construction, for example, may well exceed loads likely to be encountered during normal building operation. Additional loads or odd element shapes may require additional reinforcement to be used or support using 'strongbacks' to be employed during erection.

7.5 PREFABRICATION AND CASTING

All concrete materials and lifting and bracing inserts to be used in manufacturing the elements should meet the requirements of the relevant Australian Standard. Lifting inserts should be 'cast-in' only. Bracing inserts should preferably be 'cast-in' and should be capable of resisting all loads likely to be encountered

during construction and should be appropriately located in the element.

Casting beds for on-site casting need to be properly located to take account of the need to move materials and cast elements and should have sufficient capacity to meet project requirements. If capacity requirements necessitate casting in stacks then additional care is required in relation to formwork, separation of elements and production sequencing. Once the elements have been cast, they must be marked to identify their location in the structure and tested for conformance with specification requirements.

7.6 HANDLING, STORAGE AND TRANSPORTATION

The handling and movement of the large precast elements create a number of safety risks. Ideally, with proper planning, the amount of handling of precast elements can be minimised. This is a basic element of risk management at this stage of a project. Ensuring that elements do not contact one another during handling reduces safety risks and the potential for damage to the elements.

Storage of precast elements also needs to be managed to reduce safety risks and damage. Temporary storage on suspended floors or beams requires engineering approval. Stored elements should be protected from impact from cranes or vehicular movement. Crane selection and operation are of critical importance to reduce safety risks during handling and erection. Ensuring that crane lifting capacity is appropriate is critical and use of a larger crane than is nominally required can reduce the number of lifts. Adequate clearance for crane operations (and particularly around power lines) must be maintained.

Transport of precast elements to the project site requires good planning. Load limits and site locations must be considered and a good traffic management plan at the site is required to ensure risks are minimised. Support frames on the trucks must be able to support the elements and need to be properly secured and remain so, particularly during loading and unloading of elements.

7.7 ERECTION

The erection of precast elements brings with it, significant safety risks. Proper planning of this phase of activity is fundamental. With systems involving supporting and bracing of elements during an ongoing construction process, there is a risk of progressive failure if one element falls and triggers a collapse of the whole structure. This eventuation must be prevented at all costs.

In the erection phase the safety issues require that only personnel involved in the erection process be present – in or around the structure. During movement of elements they should not travel over a person on the site and elements being lifted should lean away from the crane. After temporary erection has been completed, a thorough inspection of bracing and supports should be carried out. Operation of mobile equipment around braced structures should be prevented or minimised. Where ‘working at heights’ is occurring the appropriate measures to prevent falls must be in place.

Bracing and propping must be able to carry all required loads and should meet the requirements detailed in the shop drawings. Extra loads (e.g. installation of roof systems) should not be imposed on temporarily braced elements (**Figures 20.22** and **20.23**).

While some builders seek to increase productivity by erecting panels on recently poured slabs, the strength of the slabs must be properly considered to ensure safety during the erection process. Panel bracing is attached to the slab via an anchor, and these anchors are typically cast-in inserts in the slab. The strength of the slab must be sufficient to ensure that the inserts do not ‘pull out’ of the slab under load. The design methods in AS 3600 only apply for concrete strengths >20 MPa, while the concrete capacity design procedure in AS 3850.1 (Appendix B) is based on the characteristic compressive strength at 28 days. For a concrete age of <28 days the design must be based on the characteristic compressive strength at the age of loading. Any departure from the requirements of these Australian Standards must be signed off by the Erection Design Engineer.



Figure 20.22 – Bracing of Precast Panel – Braces fixed into Slab Floor and Panel^{20.2}



Figure 20.23 – Bracing Panel while Construction Progresses

Proper consideration also needs to be given to embedment depths for the cast-in bracing inserts. For inserts where the embedment depth is <150 mm, small variations in embedment depth can affect the inserts’ load capacity [4].

Grouting can be applied once the structure has been properly positioned and aligned. Supporting structures should not be removed until the grout has gained sufficient strength.

7.8 CONNECTION INTO THE FINAL STRUCTURE

The erection program and its effect on the whole structure need to have been considered in the project planning. All likely loads – whether related to construction activities or other conditions (e.g. wind loads) – should have been accounted for. Connection of the

concrete elements into the whole structure should follow the design requirements and any variation from these needs to be approved by the design engineer.

8 PRECAST CONCRETE AND THE ENVIRONMENT

In addition to some of the engineering benefits that precast has over conventional in-situ concrete casting, it also has some environmental benefits.

Through its manufacture in a factory environment, greater control over element dimensions and concrete quality can be achieved. In both cases this allows a reduction in material quantities – less concrete due to higher precision and less cement due to greater control over strength performance. Both yield lower levels of embodied energy and embodied CO₂ when considering the environmental performance of the as-built structure, though the implications of using steam curing where it is used must also be factored into any calculations.

The greater control over factory production also leads to lower levels of waste of both raw materials and plastic concrete.

From a comfort perspective, the insulating characteristics (both thermal and sound) of precast concrete construction are advantageous. Further, there are no volatile organic compounds emitted from concrete.

The durability of high-quality concrete means low risks from water and pest damage and as a highly durable material precast concrete will retain its serviceability over many decades.

9 REFERENCES

- 1) National Precast Concrete Association Australia and Concrete Institute of Australia, *'Precast Concrete Handbook'* (September 2002), ISBN 0 9577467 1 7
- 2) National Precast Concrete Association of Australia, *'Precast Concrete*

Handbook' (October 2009), ISBN 978-0-9577467-3-2

- 3) National Precast Concrete Association of Australia, *'Precast Practice Notes – Joints in Precast Concrete Buildings'*, NPCAA (June 2003)
- 4) Worksafe Victoria, *'Erection of concrete panels on early-age low strength concrete'* (August 2017)

10 RELEVANT AUSTRALIAN STANDARDS

- 1) AS 1379 – *Specification and supply of concrete*
- 2) AS 1530.4 – *Methods for fire tests on building materials, components and structures, Part 4: Fire resistance tests for elements of construction*
- 3) AS 3600 – *Concrete structures*
- 4) AS 3610 – *Formwork for concrete*
- 5) AS 5100 – *Bridge design, Part 1: Scope and general principles*
- 6) AS 3850 – *Prefabricated concrete elements, Part 1: General requirements*
- 7) AS 3850 – *Prefabricated concrete elements, Part 2: Building Construction*

11 OTHER REFERENCES

- 1) Ryan WG and Samarin A (Eds.), *'Australian Concrete Technology'*, Longman Cheshire Pty Ltd (1992), ISBN 0 582 71245 9
- 2) CCAA, *'Guide to Concrete Flatwork Finishes'*, CCAA T59 (2008)
- 3) CCAA and Concrete Institute of Australia, *'Guide to Tilt-Up Design and Construction'*, CCAA T55 and CIA Z10 (2005)
- 4) CCAA and Standards Australia, *'Reinforced Concrete Design'*, CCAA Handbook T38 (July 2011), ISBN 878 1 877023 28 6
- 5) CCAA, *'Form Liners – Achieving Surface Relief and Texture'*, Briefing 06 (June 2002)
- 6) CCAA, *'Colour and Texture in Concrete Walling'*, Briefing 03 (September 2006)
- 7) National Precast Concrete Association of Australia, *'Hollowcore Flooring – Technical Manual'*, NPCAA (July 2003), ISBN 0 9577467 2 5
- 8) National Precast Concrete Association of Australia, *'Hollowcore Walling – Technical Manual'*, NPCAA
- 9) Australian Government, *'National Code of Practice for Precast, Tilt-Up and Concrete Elements in Building Construction'* (February 2008), ISBN 978 0 642 32784 0

End Notes:

20.1 The lower part of the figure was adopted from *'Bradleys Head Lighthouse - Sydney Harbour'*, by Wade Homewood, licensed under the Creative Commons Attribution-Share Alike 3.0 Unported license, - <https://commons.wikimedia.org/wiki/File:Bradleys Head Lighthouse Sydney.jpg>

20.2 Photo adopted from U.S. Army Corps of Engineers, Public Domain license, <https://www.flickr.com/photos/usacehq/4888270641>

CONTENTS

1. OUTLINE.....	2
2. PROPERTIES OF TREMIE CONCRETE	3
2.1 GENERAL	3
3. TESTING OF TREMIE CONCRETE.....	3
3.1 GENERAL	4
3.2 PLASTIC PROPERTIES.....	4
3.3 HARDENED PROPERTIES.....	5
4. MIX DESIGN AND SPECIFICATION OF TREMIE CONCRETE	6
4.1 GENERAL	6
4.2 MIX DESIGN	6
4.3 SPECIFICATION	6
5. REFERENCES	8

1. OUTLINE

Tremie concrete is used for placement of structural members under deep excavations such as bored-pile foundations, retaining contiguous/secant pile walls, diaphragm and cut-off walls (CIA Recommended Practice Z17 [4]). Depending on construction techniques, Tremie concrete can be placed under either dry or wet conditions. A tremie pipe is normally employed to place this type of concrete.

The Tremie pipe is a smooth straight steel pipe with a diameter that is usually from 150 mm to 300 mm (between 8 times and 16 times the maximum aggregate size of the concrete mix), and long enough to reach the bottom of a deep bored pile. It has a hopper, or a chute attached on top so the filling of the concrete can be maintained. The hopper capacity should be equal to the volume of pipe being employed (see **Figure 21.1**). The Tremie pipe facilitates concrete placement at deep locations.

In dry construction, concrete is sensitive to segregation due to the great height of falling and possible contact with reinforcement or surrounds. In wet construction (i.e. placing concrete underwater or under a drilling support fluid), major difficulties are from the washout of

finer from the mix. The key ability of the mix is for it to flow under its own weight.

The operation of a tremie setup is generally from either a working platform (set up over water) or it can be suspended from a crane. In most cases the tremie hopper is filled from a concrete pump or crane and kibble (with chute fitted). Where a large caisson or deep foundation requires multiple filling points then it is likely that more than one tremie will be used in suitable locations to ensure that the concrete will fill the structure uniformly from the base.

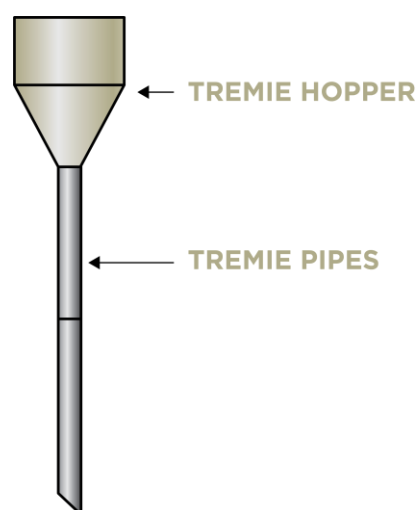

Figure 21.1 – Tremie Pipe and Hopper Setup

When a tremie concrete pour starts it is usual to 'plug' the pipe at the base of the hopper with a 'pig'. The 'pig' is normally made of a spherical foam rubber ball with diameter greater than the diameter of the tremie pipe. The purpose of this is to separate the first concrete placed from the water to avoid washout of the concrete. The 'pig' descends down the tremie pipe and eventually comes out at the bottom of the pipe and floats up to the water surface. This allows the concrete to flow out onto the floor of the structure and to surround the tremie pipe with minimal washout and segregation of the concrete.

The bottom of the tremie pipe must be maintained in the concrete at all times and as the quantity of concrete placed rises, the ideal position of the tremie pipe end is approximately 1.5 m below the rising concrete/water interface surface. To maintain this height the tremie will need to be carefully lifted during the placement

with shortening of the pipe by removal of pipe segments below the hopper as required.

The tremie concrete must be placed at a rate that avoids setting of the concrete in the tremie pipe or above the tremie pipe in the structure. This is usually achieved using retarding or slump retaining admixtures in the concrete mix.

2. PROPERTIES OF TREMIE CONCRETE

2.1 GENERAL

Similar to super-workable concrete, Tremie concrete requires good flow characteristics (e.g. filling ability, flowing ability and passing ability) and stability (i.e. water retention, fines washout resistance and segregation resistance). **Table 21.1** is adapted from CIA Recommended Practice Z17 to illustrate mix design properties of tremie concrete compared to other types of concrete.

Table 21.1 – Properties of Tremie and Other Concretes

Qualitative Parameters	Normal Concrete	(Wet) Tremie Concrete	Super-Workable Concrete
Binder Volume	Low	Medium	Medium
Coarse Aggregate Volume	High	Medium	Medium/Low
Paste Volume	Low	Medium	Medium/High
Paste Viscosity	Low	Medium	Medium/Low
Concrete Viscosity	High (flow by vibration)	Medium/Low	Medium/Low
Concrete Yield Stress	High	Medium/Low	Low

When placing concrete underwater, it is usual to add more cement to the mix than would normally be required for the specified strength

so as to improve mix workability and reduce the risk of washout. Some specifications nominate as much as 10% more cementitious material.

Discharge at the end of the Tremie pipe requires the concrete to flow to fill the forms or voids, and in most situations, it is impossible to see if that is happening under water.

Because of the lack of visibility, it is suggested that horizontal flow of highly flow-able concrete in wet construction be limited to a radius of flow of 3 m. For dry construction, free fall height (i.e. distance between the exit point of the Tremie pipe and the top of rising concrete surface) is suggested to be limited to 3 m – with the horizontal flow limited to 1.5 m – to avoid possible segregation (CIA Recommended Practice Z17).

For underwater applications, tremie concrete needs to be placed at slumps greater than 175 mm. In some conditions where high flowing concrete properties are required the target slump may need to be increased to around 250 mm with a slump flow between 400 mm and 550 mm [7].

Table 21.1 demonstrates that Tremie Concrete Rheology is positioned between that of Normal Concrete and Super-workable Concrete (refer to Section 22 of this Guide).

The key characteristics of tremie concrete are:

- Workability (an ability to self-compact under gravity);
- Workability retention (maintain its workability for the period of placement);
- Stability (resistance to segregation, bleeding and filtration).

Not surprisingly, some of these requirements are shared with those of super-workable concrete.

3. TESTING OF TREMIE CONCRETE

3.1 GENERAL

Tremie concrete can be tested for hardened properties in much the same way as standard concrete (refer to Part VIII, Section 26 of this Guide). The key differences in test methods relate primarily to its plastic properties.

3.2 PLASTIC PROPERTIES

Tremie concrete requires testing for plastic properties that may differ from the test methods used for normal concrete. The key properties that help describe the rheology of a tremie concrete mix are:

- Consistency;
- Viscosity;
- Resistance to segregation;
- Workability retention;
- Bleeding;
- Filtration;
- Heat of hydration.

Testing for these properties is discussed in the following sub-sections.

Consistency

The common test method used is the slump test carried out to AS 1012.3.1 [3]. The traditional tremie concrete target slump specification has been between 180 mm and 240 mm. As the specified slump starts to rise above 220 mm it is found that specifying the slump does not provide a sufficiently accurate measure of rheology and so the slump flow tested in accordance with AS 1012.3.5 becomes a more relevant measure.

Viscosity

EFFC/DFI Task Group [7] suggests a test for assessing the viscosity of a tremie concrete based on the slump flow test. This is similar to the T_{500} test used for Super-workable concrete but is suitable where the specified slump flow is between 400 mm and 500 mm. The test referred to as the 'slump flow velocity' and is assessed by determining the time from lifting the slump flow cone until the flow ceases. If the average final flow diameter was exactly

500 mm then this time measurement would be the T_{500} value for that test. In the case of the 'slump flow velocity' (SFV), the value is calculated from the final flow diameter in mm (D_{final}), and the time to reach that diameter (t) in seconds, using this formula:

$$SFV = (D_{final} - 200) / t \quad \dots \text{Eq.21.1}$$

In the case where $D_{final} = 500$ mm, the $SFV = 300/T_{500}$. So, if T_{500} equals 6 seconds then the SFV equals 50 mm/sec.

The SFV is only relevant where a slump flow is specified between 400 mm and 550 mm.

Resistance to Segregation

Plastic concrete in deep foundations relies on its shear yield strength to prevent segregation once placed. The relatively high density of coarse aggregate compared to the concrete mix mortar fraction can lead to segregation of the mortar from the coarse aggregate. This static form of segregation is exacerbated by significant retardation of the concrete.

A suitable method for assessing this form of segregation is provided in ASTM C1610 'Standard Test Method for Static Segregation of Self-Consolidating Concrete Using Column Technique'. The method used in this test is to form a column of the plastic concrete to be assessed, leave it to stand for a defined period of time (e.g. 15 minutes to 2 hours depending on the retardation of the mix) and then assess the coarse aggregate content of the concrete in the top 25% of the column concrete volume compared with the coarse aggregate content in the bottom 25% of the column concrete. The coarse aggregate is removed by washing the concrete over a 4.75 mm sieve and retaining the coarse aggregate fraction.

The difference in mass of SSD coarse aggregate from the bottom section compared to the top section is expressed as a percentage of the total mass of coarse aggregate from both sections. Typically, the maximum allowable static segregation is 15%.

Workability Retention

Workability retention is best assessed using a sample of concrete that is prevented from losing moisture during the test period. The slump test or slump flow test (as specified) is

carried out at regular intervals (30-minute intervals until complete) until significant slump loss is detected. A significant slump loss would be a reduction in slump flow of 50 mm.

With some types of slump retention admixtures, the slump flow may increase slowly after mixing before slowly reducing after a period. If this is detected, then the test interval may need to be shortened to capture the range of slump flow results over time as flow that is too high may promote segregation of the mix.

Bleeding

Bleeding of concrete is common to all types of concrete but is a greater issue in deep pile construction. Bleeding is a form of segregation where the mix water separates from the binder. Under the significant pressure gradients that exist in the concrete mixture as a result of differential density between binder and aggregates and water, water is driven up to the surface of the concrete. In some deep piles and foundations this shows up as 'bleed channels' that may follow up the outside of the pile or along reinforcement. This channelling can lead to washout of binder and some fines in the local area and so can be detrimental to the concrete structure's durability.

To reduce the tendency for bleeding it is often necessary to amend the grading of the mix binder and other fines with the possible addition of ultra-fine materials to reduce total bleeding and bleeding rate. A common specification for 'bleeding' is to limit the maximum bleed rate.

The test method for bleeding is AS 1012.6 'Methods of testing concrete, Part 6: Determination of bleeding of concrete' [9].

Filtration

The property of 'filtration' in the concrete mix may be related to bleeding in deep foundations and piles. The effect of bleeding under pressure can also drive water out of the concrete and into the surrounding ground. The impact of this is a rapid loss of concrete workability.

CIA Z17 [4] and EFFC/DFI Task Group [7] suggest the use of the Bauer Filtration test for assessing this property of the tremie concrete,

as well as setting maximum loss of water through the filter under a pressure of 5 bar (approximately 500 kPa).

Heat of Hydration

One property of tremie concrete that may be of concern is the potential for the heat developed during hydration of the binder to lead to unacceptable temperature rise. The conditions where this may be of concern are:

- When the structure (pile or deep foundation) has minimum dimensions of 600 mm or more;
- The binder combination selected has not been designed to reduce the temperature rise in the concrete;
- The maximum estimated concrete temperature exceeds 75°C.

In these cases, the mix design, mix delivery temperature and possibly the structure's reinforcement may require review to ensure durability of the structure. The mix binder constituents may need to include higher proportions of supplementary cementitious materials such as fly ash and/or ground granulated blast furnace slag. The initial temperature of the concrete can also be lowered to reduce the maximum temperature of concrete after placement (refer to Section 18 of this Guide in relation to *Hot weather concreting* and temperature control).

Assessing the potential temperature rise in a concrete mix is best assessed using a 1 m x 1 m x 1 m form-ply box filled with the proposed concrete mix and a thermocouple setup to monitor temperature rise (refer to CIRIA C660 [10] section 7.2.1).

3.3 HARDENED PROPERTIES

The standard tested properties for hardened concrete also largely apply to tremie concrete, namely:

- Compressive strength;
- Tensile strength;
- Drying Shrinkage;
- Modulus of elasticity;
- Creep.

For a given compressive strength and plastic density of tremie concrete the relationships between compressive strength and tensile strength, modulus of elasticity and creep are expected to be the same as for normal concrete (refer to AS 3600 [1]).

Drying shrinkage of tremie concrete is dependent on mix design and due to slightly lower coarse aggregate contents may be slightly higher than that in some normal concrete mixes, but still conforming to AS 1379 [2].

4. MIX DESIGN AND SPECIFICATION OF TREMIE CONCRETE

4.1 GENERAL

In Part III of this Guide the mix design of normal concrete is discussed. The basic steps of mix design outlined in Part III of this Guide are the same for tremie concrete as for normal concrete – with the necessary corrections for reduced coarse aggregate content, slump, minimum binder content and binder combination.

4.2 MIX DESIGN

The total cementitious content of a tremie concrete mix should be greater than 400 kg/m³ with a maximum particle size of coarse aggregate of 20 mm – where the minimum spacing between reinforcement bars in the structure are 80 mm or greater. If spacing between reinforcement is less than 80 mm then the maximum aggregate size should be no more than 25% of the minimum spacing. The inclusion of SCM's in the mix (e.g. Ground slag or fine grade fly ash) can assist with reducing the temperature rise in the concrete as well as with improved flow-ability and cohesiveness of the concrete.

Anti-wash out admixtures can be of great advantage with the placement of tremie concrete underwater. These admixtures stabilise the water in the concrete and reduce bleed as well as helping to reduce any loss of fines during placement and setting.

The water content of tremie concrete will depend on the admixture combination being used but would be expected to be between 170 litre/m³ and 200 litre/m³ for the purposes of developing a preliminary mix design with 20 mm maximum sized aggregate.

When choosing a mix design method, it is recommended to use the 'British Road Note 4' method as set out in Part III of this Guide. Referencing Figure III.3 of this Guide, it is recommended that for tremie concrete with 20 mm maximum sized aggregate the combined aggregate grading curve 3 is used for binder contents as high as 600 kg/m³, and the combined aggregate grading curve 4 for binder contents as low as 400 kg/m³. If the binder content exceeds 600 kg/m³ then the mix may need a careful review in terms of the impact on temperature rise in the hardening concrete.

The admixture selection will depend on the specified properties of the tremie concrete mix. For example, if the concrete must retain its consistency for two hours after placement then it is likely that a slump retaining admixture will need to be used in conjunction with a high range water reducer or medium range water reducer (depending on the target slump or slump flow). If there are concerns that the mix may be washed out when placed under water, then an anti-washout admixture may also be required.

The preliminary design air content of a tremie concrete mix should be between 2.0% and 4.0% as a guide, though the actual mix value will be dependent on the admixture and material selection.

It is essential that a proposed tremie concrete is trial mixed in the laboratory and on-site to ensure that its plastic and hardened properties are suitable as well as conforming to the specified properties.

4.3 SPECIFICATION

Specification of tremie concrete is largely aimed at achieving the necessary plastic properties as well as hardened state properties. The tremie concrete should be able

to fill the forms with no compaction applied and without significant segregation, washout or bleeding.

The hardened concrete specified properties will be as for Normal Class concrete and as detailed in AS 1379 [2].

Typical specified plastic properties will include:

- Slump or slump flow target (and acceptable range);
- Slump flow velocity;
- Workability retention;
- Static segregation;
- Bleeding;
- Bauer filtration;
- Maximum concrete temperature rise.

Generally, a selection of these tests may be specified as well as a testing frequency. The EFFC/DFI Task Group [7] document does provide some useful guidelines on specifications for these tests and has influenced the typical values provided in **Table 21.2**.

Table 21.2 – Typical Tremie Concrete Plastic Property Test Specified Values and Allowable Variation

Test Method	Target Range	Max.	Min.
Slump (mm)	180 - 220	S+40	S-40
Slump flow (mm)	400 - 800	SF+50	SF-50
Slump flow velocity (mm/sec)	10 - 50	SFV+5	SFV-5
Workability Retention (mm)	Specified	N/A	S-40 S-50
Static Segregation (%)	≤15	SS+2	N/A
Bleeding Rate (mL/min)	≤0.1	BR+0.02	N/A
Bauer Filtration (mL)	≤23	BF+3	N/A
Maximum Temp. Rise (°C)	Specified T	T+3	N/A

5 REFERENCES

- 1) AS 3600 – *Concrete structures*
 - 2) AS 1379 – *Specification and supply of concrete*
 - 3) AS 1012.3.1 – *Determination of properties of concrete – Slump test*
 - 4) CIA Z17 Recommended Practice, '*Tremie Concrete for Deep Foundations*', Concrete Institute of Australia
 - 5) AS 2758.1 – *Aggregates and rock for engineering purposes – Concrete aggregate*
 - 6) AS 1012.3.5 – *Determination of the properties related to consistency of concrete – Slump flow, T₅₀₀, J-ring test*
 - 7) EFFC/DFI Task Group, '*Guide to tremie concrete for deep foundations*', European Federation of Foundation Contractors & Deep Foundation Institute
 - 8) ASTM C1610 – *Standard Test Method for Static Segregation of Self-Consolidating Concrete Using Column Technique*
 - 9) AS 1012.6 – *Methods of testing concrete, Part 6: Determination of bleeding of concrete*
 - 10) CIRIA-C660, '*Early age thermal crack control in concrete*', P.B. Bamforth
-

CONTENTS

1. OUTLINE.....	2
2. THE USES OF SUPER-WORKABLE CONCRETE	2
2.1 GENERAL.....	2
3. DEFINING SUPER-WORKABLE CONCRETE	3
3.1 GENERAL.....	3
3.2 CONCRETE RHEOLOGY	3
4. MATERIALS FOR SUPER-WORKABLE CONCRETE	4
4.1 BINDERS & MINERAL ADDITIVES.....	4
4.2 COARSE AND FINE AGGREGATES.....	4
4.3 ADMIXTURES.....	5
5. TESTING OF SUPER-WORKABLE CONCRETE	6
5.1 GENERAL.....	6
5.2 PLASTIC PROPERTIES	6
5.3 HARDENED PROPERTIES	9
6. MIX DESIGN AND SPECIFICATION OF SUPER-WORKABLE CONCRETE.....	9
6.1 GENERAL.....	9
6.2 MIX DESIGN.....	10
6.3 SPECIFICATION.....	12
7 REFERENCES	13

1. OUTLINE

Traditionally concrete has always required a significant compaction effort to consolidate it to a degree that will produce optimal hardened properties. In many circumstances where concrete is to be placed it would be desirable to produce a concrete that requires little or even no compaction but still achieve all required properties.

Attempts to achieve this 'self-compacting' plastic state of concrete by using significant additions of water normally led to segregation of the concrete and poor hardened concrete properties. In the mid 1970's the availability of

'superplasticisers' (now called High Range Water Reducers) in various locations around the world (including Australia) provided a key ingredient for producing a useful form of 'Super-Workable Concrete'.

As high range water reducing admixtures and concrete mix designs have developed over the years, potential for producing non-segregating, partly or fully self-compacting concrete has become a reality and is now a more common concrete product. In Australia we have referred to this range of products as 'Super-Workable Concrete' but internationally they are also known as 'Self-Consolidating Concrete' or 'Self-Compacting Concrete'.

2. THE USES OF SUPER-WORKABLE CONCRETE

2.1 GENERAL

Super-workable concrete (SWC) is not suitable for use in every concrete application but does have certain features and benefits that will make it a suitable and efficient product to use in certain applications.

Some of the benefits of SWC are listed below:

- Reduced noise on site from equipment used to compact normal concrete;
- Possibly lower numbers of personnel used in placement of SWC with likely lower construction costs;
- Improved and more consistent compaction of concrete;
- Improved off-form finish quality.

The key reasons for this product not currently taking a majority position in the pre-mixed concrete products is the higher level of complexity in producing a consistent and reliable SWC. This complexity relates to issues like selecting suitable constituent materials, effective mix design and evaluation, control of mix water content and the level of supervision required to guarantee performance of the concrete in its plastic state.

Controlling these factors will normally lead to a more costly mix than would be the case for more easily controlled 'normal' concrete. The

following sections provide a guide to designing, specifying and controlling the SWC product.

While there are many higher slump concrete products in regular use these may not meet the requirements of SWC.

3. DEFINING SUPER-WORKABLE CONCRETE

3.1 GENERAL

The name 'Super-workable Concrete' was first suggested in Australia by the committee responsible for the Concrete Institute of Australia Z40 document of the same name (see reference [4]). The committee for this guideline recommended some suitable test types and limits for this range of products. In terms of the more common consistency test, slump, SWC is taken to refer to concrete mixtures that have a slump of 250 mm or greater.

If a well-proportioned normal class concrete that is designed for an 80 mm target slump had sufficient water added to it to achieve a slump in excess of even 240 mm it is likely that it would segregate during placement [i.e. the mortar would separate from the coarse aggregate; the paste (i.e. the water + admixtures + binder) would separate from the mortar; and possibly the water would separate from the paste – i.e. heavy bleeding].

To counteract the effects noted by adding water to a standard mix, the paste viscosity needs to be increased to a level where the coarse and fine aggregate will be prevented from separating from the paste while maintaining the consistency of the concrete mix. Water/Binder ratio has a significant impact on paste viscosity as have the admixtures and additives used in the SWC mix design. The study of this behaviour of concrete is generally referred to as 'Concrete Rheology' and is discussed in the following.

3.2 CONCRETE RHEOLOGY

While Slump measurements can provide some indication of the amount of compactive effort that will be required to compact plastic concrete, they have a limited range of applicability. Concrete mixes with the same Slump value can require very different amounts of effort to fully compact them. SWC introduces additional complexities and workability measurement requires a different approach.

Work by Wallevic and others [6] has shown that the Bingham Model (**Figure 22.1**) provides a means of understanding the rheology of concrete mixes. These studies are carried out using rheometers which measure the shear rates obtained when a range of shear stresses are applied to a concrete mix. From this work, two definitive properties can be determined, namely (1) the Shear yield stress (τ_0), and (2) the Plastic Viscosity (μ).

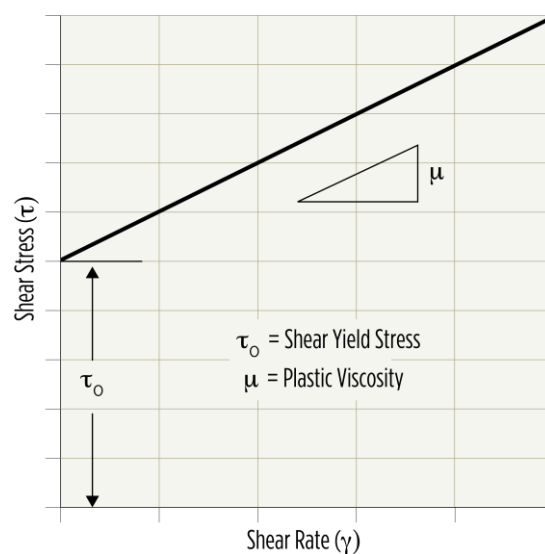

Figure 22.1 – Bingham Model of Shear Stress Vs. Shear Strain Rate

The Shear Yield Stress reflects the amount of energy that needs to be imparted to a mix to cause it to flow, while the Plastic Viscosity reflects the viscosity of the mix – that is, the ease with which it will flow.

When comparing flow characteristics of a concrete mix with a (say) 100 mm slump with those of a SWC in a rheometer, it would be seen that the low-slump concrete would have a relatively high Shear yield stress value and a

steeper Plastic Viscosity curve compared to the SWC. In practical terms, it would take more effort to make the 100 mm slump concrete begin to flow and higher levels of effort to compact and finish the concrete. The SWC would have a low Shear yield stress value and a relatively flat Plastic Viscosity curve.

These characteristics of SWC help guide the development of test methods for assessing SWC and assist with providing an understanding of the behaviour of SWC in dynamic processes (such as compaction or pumping).

The factors in a concrete mix design that impact on concrete Shear Yield Stress are largely:

- Water content (higher water content = lower τ_0);
- Type of admixture and dosage;
- Quantity of paste at the same W/B ratio (higher paste volume = lower τ_0);
- Binder components (e.g. replacing GP Cement with fly ash is likely to lower τ_0).

The factors in a concrete mix design that impact on Plastic Viscosity are largely:

- Water/Binder ratio (higher W/B ratio = lower μ);
- The presence of viscosity modifying admixtures (VMA) that are designed to increase viscosity in SWC;
- Water content (lower water content = higher μ).

The impact of the proportion and properties of coarse and fine aggregates in the concrete mix design on these two rheology factors is more complex and will be discussed in '*Materials for Super-workable concrete*' below.

4. MATERIALS FOR SUPER-WORKABLE CONCRETE

4.1 BINDERS & MINERAL ADDITIVES

When designing a SWC mix one of the most critical decisions will be that of the combination of materials to be used in the binder.

While it is possible that a Type GP or Type HE Cement may be a sole binder component, this is unlikely unless the GP or HE cements display a level of consistency, compatibility with the selected admixtures and ability to avoid segregation at the design water/binder ratio. Assessing this is discussed in 4.3 below.

Along with a Portland cement product some of the common supplementary cementitious materials (SCM's) that are used in SWC are:

- Fly ash (generally Fine Grade but not universally);
- Ultra-Fine Fly ash;
- Ground granulated blast furnace slag;
- Amorphous silica.

These SCM's need to be carefully selected and blended with a suitable Portland cement with particular attention being paid to their properties including particle size distribution, presence of fine carbon and quality consistency.

The European experience has been that inert mineral additives can also be used with Portland cement to improve the mix rheology and resistance to segregation by maintaining a higher paste viscosity. Some examples of these are:

- Ground limestone powder (already present to a minor degree in many Type GP cements);
- Ground silica;
- Some forms of stable clay (e.g. Attapulgate).

The focus on mineral additives is generally to achieve very small average particle size. When these are used the relative proportion in the mix will be significantly lower than that of a coarser SCM.

4.2 COARSE AND FINE AGGREGATES

Both coarse and fine aggregates will influence the SWC rheology. The individual properties of these aggregates are discussed in this section, but the blending of aggregates is more appropriately discussed in 6.2 '*Mix Design*'.

Research has demonstrated that coarse aggregate with poor shape will lead to higher shear yield stress and when the SWC mix is corrected by water addition or admixture adjustment, it is more prone to segregation. Coarse aggregates with consistently good shape (round or cubical) will improve the flow characteristics of the concrete.

The maximum aggregate size of SWC will generally be no more than 20 mm and have a combined coarse aggregate grading that is continuous rather than single sized. In cases where higher slump flow and improved passing ability (see 5.2 '*Plastic Properties*') are required it may be necessary to reduce the maximum aggregate size to 14 mm or 10 mm in some cases.

As the mortar density of SWC is likely to have a plastic density between 2,100 kg/m³ and 2,200 kg/m³ it is also important to source coarse aggregates which comply with the requirements of AS 2758.1 and useful if the aggregates also have a particle density less than 2,700 kg/m³ to lower the risk of segregation of the coarse aggregate from the mortar.

The fine aggregate plays a major role in the resistance of the SWC mix to segregation. A single fine aggregate or blend of several fine aggregates should comply with AS 2758.1 and have a uniform grading (no single particle size range between consecutive standard sieves being greater than 30% is ideal). The average fine aggregate particle size is reflected by having a fineness modulus between 2.40 and 2.60 (see Part III of this Guide).

The use of a proportion of manufactured sand in the sand blend may be beneficial. In this case a proportion of the manufactured sand fines (passing 75-micron sieve size) can be considered as a part of the binder. Care should be exercised in the selection of sand sources in regard to maintaining consistent grading.

4.3 ADMIXTURES

As noted in the outline of this section, a key to developing SWC has been the use of 'High range water reducing admixtures' (HRWR). The early forms of these admixtures were based on sulphonated melamine formaldehyde condensates and sulphonated naphthalene formaldehyde condensates. These were moderately effective but had a short 'slump life' which meant that it was difficult to use these admixtures by adding them at the concrete plant. This did see some popularity of site added HRWR to try and overcome the issues of more rapid slump loss.

More recent innovations in HRWR admixtures has seen benefits with the introduction of poly-carboxylic ether (PCE) based admixtures to Australia in the late 1990's. Over time newer and improved versions of HRWR are becoming available.

Other types of admixtures used in SWC may include:

- Viscosity modifying admixtures (VMA);
- Slump retention admixtures;
- Standard retarding admixtures (Type Re).

Viscosity modifying admixtures aim to increase the plastic viscosity of concrete but may also increase the shear yield stress of the concrete. They can be very useful when designing a SWC mix with a total binder content at the lower end of the acceptable range (see 6.2 '*Mix Design*' following).

Slump retention admixtures are generally a combination of PCE based HRWR with modification of the molecular structure to produce a longer working life of the concrete. These become useful when SWC placement needs to be prolonged for any reason.

Retarding admixtures are based on a number of organic and inorganic chemical solutions. The aim of using these in combination with other admixture in SWC is to prolong the setting of the concrete if required.

5. TESTING OF SUPER-WORKABLE CONCRETE

5.1 GENERAL

SWC can be tested for hardened properties in much the same way as standard concrete (refer to Part VIII, Section 26 of this Guide). The key differences in test methods relate more to the SWC plastic properties where tests to determine the mix capacity to self-consolidate become critical to acceptance.

Most tests for normal concrete hardened properties apply to SWC but may require slight variations in the casting method. Both plastic and hardened property methods are discussed in the following.

5.2 PLASTIC PROPERTIES

SWC requires testing for plastic properties that is different to the test methods used for normal concrete. The key properties that help describe the rheology of a SWC mix are:

- Consistency;
- Resistance to segregation;
- Passing ability;
- Filling ability;
- Rheology.

Each of these tests has a relationship to the concrete rheology values of the mix shear yield stress and the plastic viscosity. Setting limits on the tests help with specifying the performance of the concrete during placement.

Consistency

The traditional consistency test for normal concrete is the slump test described in AS 1012.3.1. A variation of the slump test is described in AS 1012.3.5 '*Slump flow, T_{500} and J-ring test*' test method. This test differs from the slump test in that it is measuring the average diameter (mm) of the concrete moving out from the standard concrete slump test cone as the cone (filled with SWC) is lifted.

The cone is placed on a carefully levelled base plate that must be sufficiently rigid so as not to distort during testing. The plate is made of non-absorbent material and will generally be square

or circular with a minimum diameter of 900 mm. A 200-mm circle is printed on the centre of the base plate for positioning the cone and a concentric 500-mm circle printed to assist with the ' T_{500} ' test.

Filling of the cone is carried out by pouring SWC into the cone (that is held down to prevent leakage and with a collar fitted on the top) in one motion. The SWC has no additional compaction other than the effect of pouring the SWC into the cone. When filled, the collar is removed from the cone, the top surface of the concrete in the cone levelled and any excess concrete spilled is carefully cleaned from the outer surface of the cone and base plate. The cone is then lifted vertically in a slow action that is completed in 3 ± 1 seconds.

The SWC concrete flows out from the base of the cone as it is lifted and two details are recorded:

- The time it takes for the concrete to reach the 500-mm diameter line. This time (to 0.1 second from starting to lift the cone) is recorded as the T_{500} result;
- The average diameter of the spread concrete once it ceases to flow. This is the 'slump flow' and is recorded in 'mm'.

These two properties are related to the mix shear yield stress and the plastic viscosity in the following ways:

- Slump flow is impacted to a minor degree by plastic viscosity, but it is more significantly related to shear yield stress (see **Figure 22.2**);
- T_{500} is largely related to the plastic viscosity of the concrete (see **Figure 22.3**).

It should also be noted that the actual value of shear yield stress required for a given slump flow will vary with the aggregates used in the mix. It is impacted by maximum aggregate size, coarse aggregate content of the mix as well as the concrete plastic density. It is unlikely that a mix with a 20-mm maximum size aggregate will be suitable for a specified slump flow of over 650 mm and also unlikely that a mix with 10-mm maximum size aggregate will be suitable for a specified slump flow of over

800 mm without risking segregation of the mortar from coarse aggregate as well as effects on some hardened concrete properties.

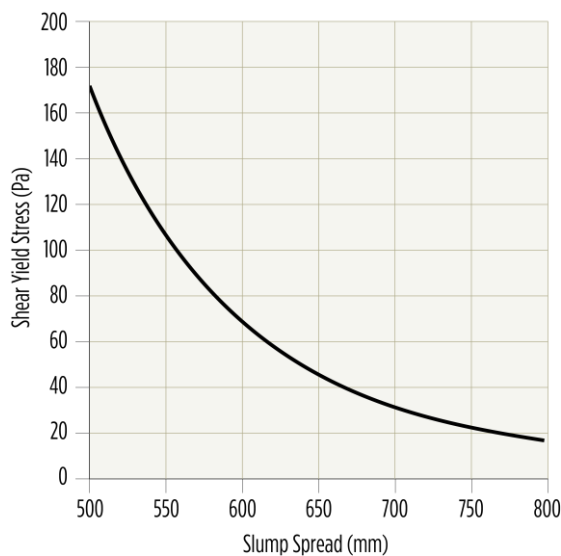

Figure 22.2 – Approximate Relationship between Slump Flow and Shear Yield Stress (based on theoretical mortar values)

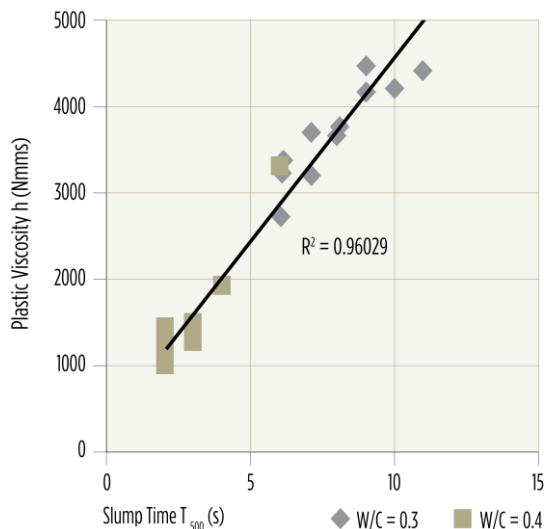

Figure 22.3- Relationship between Slump Flow T_{500} Time and Shear Plastic Viscosity (Drewnjok et al [9])

Resistance to Segregation

The resistance to segregation of SWC is typically assessed using three methods:

- J-Ring test;
- L-Box test with reinforcement bars in position;
- GTM Screen Stability test.

The J-Ring test method is detailed in AS 1012.3.5 and is an adaption of the slump flow test. In this case a ring holding a set of 12 mm diameter bars is placed on the slump flow base plate around the slump cone. When the cone is lifted the SWC flows through the bars that are set at either 40 mm, 50 mm or 66 mm spacing around the ring. Of interest in this test is the height of the concrete inside the ring and the height of the concrete immediately outside the ring after the concrete flow has ceased. The difference in these heights (expressed in mm) is an indication of the potential for the SWC to segregate during placement. The form of segregation assessed in this test is generally separation of the coarse aggregate from the mortar.

The 'L-Box' test method is detailed in CIA Z40 [4]. The test is largely aimed at assessing the passing ability and filling ability of a SWC mix but can be used to assess the potential for segregation by measuring the drop in height of the concrete before and after the set of bars placed in front of the 'gate'. This value can be reported and compared to a specified maximum value. The L-Box test is more commonly used in a laboratory for mix design verification.

The GTM Screen Stability test method is detailed in CIA Z40 [4]. The principle of the method is that a 10-litre sample of SWC is allowed to stand in a covered bucket for 15 minutes thus allowing for segregation of the aggregate in the form of settlement leaving a mortar rich layer at the top of the bucket. The top two litres of SWC in the bucket is weighed, placed on a 5 mm sieve over a pan (350 mm diameter sieve and pan assembly) and left for 2 minutes during which the mortar fraction may segregate from the coarse aggregate through the sieve and into the pan. The segregated mortar is weighed and expressed as a percentage of the original weight of the SWC sample. A higher percentage of material passing the sieve indicates a higher likelihood of segregation, while too low a value suggests that the plastic viscosity of the mix is too high and may result in poor filling ability.

If the tendency of concrete to segregate is too high by each of these test methods, then the mix may need to be adjusted to increase either

the plastic viscosity or increase the shear yield stress.

Passing Ability

Passing ability of SWC is the capability of the mix to flow through smaller gaps between reinforcement or other obstructions during concrete placement.

The common tests for this property of SWC are listed:

- J-Ring Passing Ability test;
- L-Box test with reinforcement bars in position.

Both tests have been discussed under the category of assessment for segregation but in both cases the measurement of the flowing characteristics when passing through the barrier of a set of steel bars provides an indication of the likely performance of the SWC mix.

The slump flow of SWC is also measured using the J-Ring as a barrier to flow. By comparison of the standard Slump Flow test with a repeat test using the J-Ring, it is possible to estimate the mix passing ability. As a guideline, the difference between Slump Flow and J-Ring Slump Flow diameters (average diameter in two perpendicular directions in both tests) is useful. If the flow diameter of the J-Ring test is more than 20 mm lower than the Slump Flow test or the J-Ring Passing Ability is more than 10 mm difference between the inner side and outer side of the ring then some blocking action is occurring that may need correction in the mix design.

The L-Box test method is discussed under the subject of segregation and it also assesses a value referred to as 'Passing ability'. This value is not only useful as a guide to segregation but also refers to passing ability.

Passing ability is related to both plastic viscosity and shear yield strength of SWC. If the shear yield stress is too low for the plastic viscosity to control segregation, then this will be a detriment to the passing ability. Similarly, if the plastic viscosity is too high for the shear yield stress of the SWC then this will also be a detriment to passing ability.

Filling Ability

This property of SWC measures the ability of the concrete to flow into a form and fill it without compaction effort being applied to the concrete.

The two common tests to assess this ability are:

- L-Box test;
- Orimet Test Method.

The L-Box test method also measures a value referred to as the 'filling ratio'. The filling ratio is the ratio of the height of the concrete at the front end of the L Box to the height of the concrete at the base of the filling tube. The closer the ratio is to 1.00, the better the SWC mix flowing and filling capacity is.

The Orimet test method and equipment is defined in EFNARC [5] and is a simple test that is used to assess the flow-ability of SWC. The method is simple and quick to carry out. A sample of approximately 8 litres of SWC is poured into the Orimet apparatus tube with the trap door shut (see **Figure 22.4**). The trap door is opened in less than 10 seconds from filling the tube and the time taken for the concrete to flow out under gravity is measured. The point at which the tube is emptied is considered to be when daylight can be seen through the funnel at the bottom of the tube (looking from above the tube).

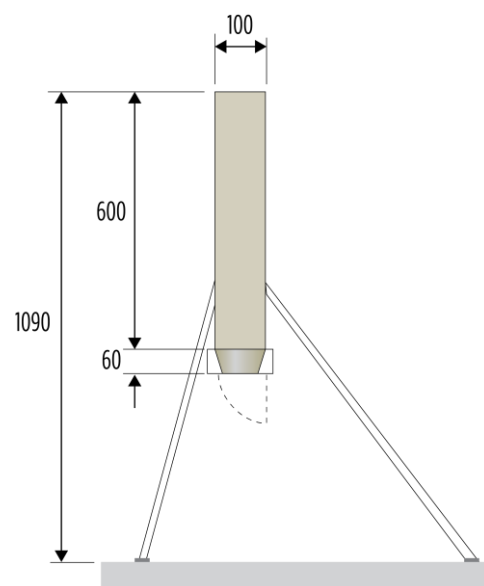

Figure 22.4 – Orimet Testing Apparatus [5] (all dimensions are in millimetres)

Typical specified flow times are less than 5 seconds using the standard 80 mm outlet of cone diameter.

Filling ability is largely impacted by the shear yield stress of the SWC. The lower the shear yield stress then the better the filling ability is – provided that the plastic viscosity is not too high.

Rheology

Testing the two rheological factors covered in sub-section 3.2 can be carried out using a rheometer. Most rheometers are only suitable as a laboratory-based aid to research and unlikely to be suitable for site quality control. There are many different commercial brands of rheometer and it is difficult to compare rheometer test results from one instrument with those from a rheometer with a different design.

A complicating factor in this is that many rheometers have rotor sizes and blade sizes that, while suitable for paste and mortar mixes, have their calibration impacted by coarse aggregate that is generally present in concrete. If a suitable rheometer is used to assess concrete it is important that the same instrument is used for all assessments of all concrete mixes on the same project. Where two or more rheometers are used on a single project or in a single laboratory, it is critical that rigorous testing comparisons of results are carried out on the same batch of concrete to assure comparable results between rheometers across a range of rheologies.

5.3 HARDENED PROPERTIES

The standard tested properties for hardened concrete also largely apply to SWC:

- Compressive strength;
- Tensile strength;
- Drying Shrinkage;
- Modulus of elasticity;
- Creep.

The only adjustments made to the test methods in each of these cases are that the normal concrete compaction methods do not apply to SWC samples. It is normal for casting test specimens that the mixed sample of SWC is placed into a suitable bucket and poured into

test moulds to fill them without rodding or vibration.

For a given compressive strength and plastic density of SWC concrete the relationship of compressive strength to tensile strength, modulus of elasticity and creep are expected to be the same as for normal concrete.

Drying shrinkage of SWC is very dependent on mix design but due to lower coarse aggregate contents may be slightly higher than that in some normal concrete mixes but still conforming to AS1379 [2].

6. MIX DESIGN AND SPECIFICATION OF SUPER-WORKABLE CONCRETE

6.1 GENERAL

In Part III of this Guide the mix design of normal concrete was discussed. While the basic steps of mix design outlined in Part III of this Guide are the same for SWC as for normal concrete, the mix proportions, the testing requirements and the importance of laboratory trials are quite different.

Key differences will be:

- The hardened properties of the SWC mix may not be the most significant influence on the final mix design. Target compressive strength for the mix may be much higher than specified as an outcome from achieving required plastic properties;
- The plastic properties of SWC will be more complex to achieve. The combined effects of binder selection, admixture selection and total mix water control will be of far greater importance in designing and producing a SWC;
- The total water content of the SWC mix will most likely be higher than normal concrete of the same characteristic strength. This varies with materials and admixtures used but are controlled by the need to achieve the required plastic properties;
- The importance of assessing proposed mix designs with laboratory trial mixes

cannot be overstated. A single mix may require several adjustments after trials so as to achieve the required plastic properties;

- In the product supply phase, SWC mix ingredients will need to be monitored carefully for variation. Minor variations in materials such as binders and aggregates that would be tolerated in normal concrete have impacts on SWC that are magnified and can send a previously conforming mix out of specification.

6.2 MIX DESIGN

The key steps in preparing a preliminary mix design for trial mixing are suggested as follows:

1. Select a suitable binder combination. In general, this will contain a Type GP or HE cement, at least one SCM and some finer particle size SCM or mineral addition;
2. Obtain test data on the selected binder materials including their particle density and particle size distribution;
3. Determine maximum aggregate size and suitable aggregate sources (see 4.2 'Coarse and Fine Aggregates'). If a higher degree of passing ability and filling ability is required, then the maximum sized aggregate may need to be reduced to 14 mm or 10 mm;
4. Obtain test data for coarse and fine aggregates to be used. Data should include particle size distribution, particle density and water absorption for all aggregates. For coarse aggregates the particle shape (flakiness index to AS 1141.15) should be investigated before using (see **Table 22.1**). Blend the coarse aggregates to achieve a 'graded' particle size distribution as recommended in AS 2758.1 Appendix B based on the maximum aggregate size. Test data for the compacted bulk density of the blend of coarse aggregates used should be assessed using the method of AS 1141.4. The fineness modulus and grading of the blend of sands selected should meet the requirements of 4.2 'Coarse and Fine Aggregates';
5. Estimate the total quantity of blended coarse aggregates used in the mix design by multiplying the compacted dry bulk density of the blend and then correcting to saturated surface dry using the aggregate water absorption values using the method detailed in Part III of this Guide;
6. Estimate the total water requirement (see **Table 22.2**);
7. Estimate the binder content needed to achieve the minimum Water/(Cement+SCM) ratio required to meet compressive strength and concrete durability requirements following the methods provided in Part III of this Guide. Check that the binder content selected has a solid volume within the recommended range given in **Table 22.2**. The solid volume is calculated using the methods detailed in Part III of this Guide. If lower than the range, then it is recommended to increase the total binder to the minimum solid volume. If higher than the range, then careful consideration is needed regarding the binder material combination;
8. Determine the solid volume of binder, coarse aggregates and water selected. It is general for SWC to assume that the air content will be 2% (0.020 m³). Deduct the air content and solid volumes estimated for binder, coarse aggregates and water to determine the remaining volume of the sand blend. Multiply this volume by the SSD particle density of the sand blend to determine the mass of fine aggregates used in the preliminary trial mix;
9. Select suitable admixtures to produce the required mix rheology, setting characteristics and slump flow retention. Admixture supplier's advice should be sought in this regard.

This preliminary mix is only a starting point for trialling. The next steps in the mix design will focus on the same methods of assessment recommended in Part III of this Guide (assessing consistency, yield, air content and appearance) but in addition to this a preliminary assessment of the plastic SWC rheology using selected methods detailed in 5.2 'Plastic Properties' is recommended. For example, a starting point would be to carry out

a slump flow, T_{500} and J-Ring passing ability test on the first trial mix. The values of these tests can be compared to **Table 22.4** in 6.3 'Specification'. Having adjusted the mix to satisfy these specified requirements then continue to test for other relevant plastic properties.

Table 22.1 – Aggregate Property Specifications

Property	Coarse Aggregate Blend	Fine Aggregate Blend
Grading	AS 2758.1 Appendix B – Graded	Maximum 30% retained between any two standard sieve sizes
Fineness Modulus	N/A	2.40 to 2.60
Flakiness Index	Max 25%	N/A
Maximum SSD Particle Density	2,700 kg/m ³	2,700 kg/m ³

Table 22.2 – SWC Mix Design Properties

Property	Recommended Range
Solid Volume of Binder	0.13 m ³ /m ³ to 0.19 m ³ /m ³
Water/Binder Ratio (by solid volume)	0.85 to 1.35
Total Water Content	160 L/m ³ to 200 L/m ³
Coarse Aggregate Content [10]	0.50 × Compacted Bulk Density (kg/m ³)

Having produced a mix that produces suitable plastic properties, the next step is to assess the hardened properties. The modifications available to improve hardened properties detailed in Part III of this Guide apply here but it must be noted that any adjustment will need another review of plastic properties until all requirements are met.

As an example, the following materials are selected to produce an SWC mix that is expected to use a blend of Type GP cement with 15% of ultra-fine fly ash in the total binder. The specified maximum W/B ratio is 0.40 to achieve the required durability:

- Type GP Cement has a particle density of 3,140 kg/m³;
- Ultra-fine fly ash has a particle density of 2,250 kg/m³;
- The coarse aggregate is a 14 mm maximum sized, graded aggregate with an SSD particle density of 2,660 kg/m³, water absorption of 1.2%, a flakiness index of 14% and a Bulk density of 1,680 kg/m³;
- The fine aggregate is a blend of two natural sands with a fineness modulus of 2.42, an SSD particle density of 2,620 kg/m³ and water absorption of 0.9%;
- An admixture combination has been selected with a dosage set at 3.64 Litre/m³ and an average specific gravity of 1.10.

In **Table 22.3** the resulting preliminary mix design is displayed using the methods provided in this section.

From a brief review of **Table 22.3**, the proportion of combined coarse and fine aggregates will have a grading with close to 50% passing the 4.75 mm sieve. This is a high percentage of sand when considering the binder volume of this mix, but it is characteristic of SWC concrete.

Table 22.3 – SWC Mix Design Example

Material	Mix Design (kg)	Material Volume (m ³)
GP Cement	385	0.1226
Ultra-Fine Fly ash	70	0.0311
Water	182	0.1820
Air Content	2.0%	0.0200
14 mm Coarse Aggregate	850	0.3196
Blended Fine Sand	842	0.3214
Admixtures	3.64	0.0033
TOTAL MASS & VOLUME	2,333	1.0000

6.3 SPECIFICATION

Specification of SWC is largely aimed at achieving the necessary rheology to produce concrete that can be placed with little or no compaction. The SWC should fill the forms without significant segregation.

Typical specified plastic properties will include:

- Slump flow target and acceptable range;
- T₅₀₀ range;
- J-Ring passing ability maximum value;
- L-Box filling ratio minimum value;
- L-Box passing ability maximum value;
- Orimet flow time maximum value;
- GTM screen stability test acceptable range.

Generally, a selection of these tests may be specified along with a testing frequency. The CIA Z40 (4) document does provide some useful guidelines on specifications for these tests and has influenced the typical values provided in **Table 22.4**.

Table 22.4 – Typical SWC Plastic Property Test Specified Values

Test Method	Target Range	Max.	Min.
Slump flow (mm)	550 - 800	T+50	T-50
T ₅₀₀ (secs)	2.0 - 7.0	T+25%	T-25%
J-Ring passing ability (mm)		10	
L-Box filling ratio	0.8 - 1.0	1.0	0.8
L-Box passing ability (mm)		10	
Orimet flow time (secs)		4	
GTM screen stability (%)	5 - 15	15	5

7 REFERENCES

- 1) AS 3600 – *Concrete structures*
 - 2) AS 1379 – *Specification and supply of concrete*
 - 3) AS 1012.3.5 – *Determination of properties of concrete – Slump Flow and T500 tests*
 - 4) CIA Z40, '*Recommended Practice – Super-Workable Concrete*', Concrete Institute of Australia
 - 5) EFNARC, '*Specification and Guidelines for Self-Compacting Concrete*'
 - 6) '*Rheology – A Scientific Approach to Develop Self-Compacting Concrete*', Proceedings of the 3rd International RILEM Symposium on Self-Compacting Concrete, O. Wallevik and I. Nielsson
 - 7) AS 2758.1 – *Aggregates and rock for engineering purposes – Concrete aggregate*
 - 8) '*Influence of the rheological properties of SCC on the formwork pressure*', MP Drewniok, G Cygan, J Golaszewski. TRANSOM: International scientific conferences on sustainable, modern and safe transport
 - 9) ACI 37R, '*Self-Consolidating Concrete*', American Concrete Institute
-

GUIDE TO CONCRETE CONSTRUCTION

T41



CEMENT CONCRETE
& AGGREGATES AUSTRALIA

PART VII - Developmental Applications

This Section examines the need for alternative binder materials and provides information on the nature and use of some of the common alternative binders under investigation. While this type of work is being carried out extensively at universities, only a small amount of commercial activity is currently underway to use the new and/or novel binder materials being developed to (potentially) replace conventional 'Portland' cement.

CONTENTS

1. INTRODUCTION	2
2. ALTERNATIVE BINDERS IN PERSPECTIVE	2
3. ALKALI ACTIVATED BINDERS (INCLUDING 'GEOPOLYMERS')	3
3.1 COMMERCIAL USES OF GEOPOLYMERS	5
4. SULFATE ACTIVATED BINDERS	5
4.1 COMMERCIAL USES OF <i>ENVISIA</i> ™	6
5. OTHER NOVEL PROCESSES	6
5.1 ' <i>CARBICRETE</i> '	6
5.2 ' <i>SOLIDIA</i> '	6
5.3 MAGNESIUM OXYCHLORIDE CEMENT.....	7
5.4 ACTIVATION OF MINERAL-BASED MATERIALS.....	7
6. ISSUES WHEN ADOPTING ALTERNATIVE BINDER TECHNOLOGIES	7
7. SUMMARY	8
8. RELEVANT AUSTRALIAN STANDARDS AND SPECIFICATIONS .	9
9. REFERENCES	9

1. INTRODUCTION

In Part X of this Guide, environmental concerns related to the use of conventional cement and concrete are discussed. Concrete is used in huge quantities worldwide – an estimated 33 billion tonnes per annum – and any product used in that quantity is likely to create environmental concerns through the sheer volume of material alone. For concrete, its volume is not the only concern. Cement production accounts for about 7-8% of the anthropogenic CO₂ produced in the world, and

as other industries 'de-carbonise', this proportion is likely to rise. It is this specific issue that has led to the interest in developing cements and binder materials that may be an effective replacement for conventional 'Portland' cement.

2. ALTERNATIVE BINDERS IN PERSPECTIVE

From a purely technical perspective, the task of developing and proving an alternative binder (or group of binders) to replace 'Portland' cement does not seem too daunting – that is, until the scale of the challenge is realised. Currently, in excess of four billion tonnes of 'Portland' cement is being produced annually throughout the world – with more than half of that being produced in China alone. From a raw materials perspective, the manufacture of 'Portland' cement is not seriously constrained as the fundamental raw materials – limestone and clay – are abundant materials. Once cement clinker has been made in the high temperature, high emissions kiln process, subsequent issues like the handling and processing of the large volumes of clinker and cement are quite simple manufacturing processes. For 'Portland' cement manufacture, the main complexity arises in the clinker manufacturing stage.

For any alternative binder system or systems, one of the primary considerations has to be raw materials availability. As will be shown later in this Section, the raw materials which are being used in the most popular alternative binders are 'wastes' – namely fly ash and blast furnace slag. When the availability of these materials is examined, it is found that there is <1 billion tonnes of these materials combined being produced annually on a worldwide basis. So, even if these materials are fully utilised in manufacturing alternative binders there is still a very significant shortfall in terms of overall 'concrete binder' requirements for any

replacement material or group of materials that might take the place of 'Portland' cement.

A variety of approaches to the development of potential alternatives to 'Portland' cement have been taken over many decades. The main approaches taken to date are described in the following discussions.

3. ALKALI ACTIVATED BINDERS (INCLUDING 'GEOPOLYMERS')

By far the largest body of work in attempts to develop alternative binders has been focussed on a suite of alkali-activated materials. While the fundamentals of alkali-activation have been known since the early 1900's, it was the work of V.D. Glukhovsky in the 1950's and that of J. Davidovits in the 1970's that more clearly defined these materials and created the path for their utilisation. As will be described below, this topic is not without its uncertainties and recriminations, but unquestionably the alkali-activated materials have created the greatest research interest, and to the relatively minor extent that it has occurred, the most significant commercial application of alternative binders.

'Portland' cement is comprised of a purposefully created set of anhydrous, synthetic minerals. When water is added to these minerals they hydrate – that is, they combine with the water to form hydrated reaction products which form as porous gels and which are very efficient at binding aggregate materials together to form mortar or concrete. The water is an integral component of these hydrate gels, and they cannot exist without it.

In contrast to purposefully made cement, alkali activated binders use as their main volumetric component, one or more vitreous (glassy) amorphous materials – some of which are natural materials and some of which are nominally 'waste' materials (e.g. fly ash and granulated blast furnace slag). These materials can be activated by a range of alkaline compounds – usually strong alkalis (e.g. sodium or potassium hydroxide, sodium or potassium carbonate, sodium silicate). The nature of the reaction products from this activation (a) depend on the chemistry of both

the base material(s) and the activator(s), and (b) are the source of some contention when it comes to naming these binder types.

The wide variety of potential reactants (base materials and activators) means that a wide range of reaction products can be obtained with the alkali activated binder systems.

(NOTE: This stands in contrast with 'Portland' cement which contains a common set of minerals (albeit often in different proportions) and a comparatively similar set of reaction products in terms of chemical composition and performance.)

The range of base materials used is quite wide and can include both low-calcium and high-calcium fly ashes; granulated blast furnace slags; metakaolin; zeolites; 'red mud' (from aluminium processing); activated clays; recycled glass and many others.

In terms of reaction chemistry, these base materials can be separated most simply into 'high calcium' and 'low calcium' groups. This basic parameter is a significant determinant of (a) the rate of activation reaction; (b) the type of reaction product; (c) the strength and durability performance of concrete; and (d) proper nomenclature.

'High calcium' materials (e.g. granulated blast furnace slag) are readily activated to form calcium silicate hydrate type reaction products and produce concrete that (a) sets at ambient temperatures and (b) produces good (early and later age) strengths and low permeability concrete.

'Low calcium' materials (e.g. low-calcium fly ash and metakaolin) are readily activated by strong alkalis to form polymeric reaction products and produce concrete that is more likely to (a) require heating to obtain adequate early-age strengths and (b) ultimately produce good concrete strengths, and (c) while this concrete tends to have higher permeability, it also tends to have excellent resistance to sulfate attack.

This latter type of alkali activated binder using primarily Class 'F' fly ash is the type patented in the 1970's by J. Davidovits. He used the name 'Geopolymer' for this product and he insists that it is a separate material from conventional alkali activated materials or AAM's as they are now

known. He uses, as the differentiator, the ‘fact’ that his ‘Geopolymers’ are polymeric materials containing cross-linked chains of Si, Al, O and other atoms and that it is this structure that gives ‘Geopolymers’ their performance characteristics. He contrasts this structure with the gel-type structure of the calcium silicate

hydrate products found in, for example, ‘Portland’ cement and (activated) slag hydration products. The contrasting processes are described in **Figure 23.1** below.

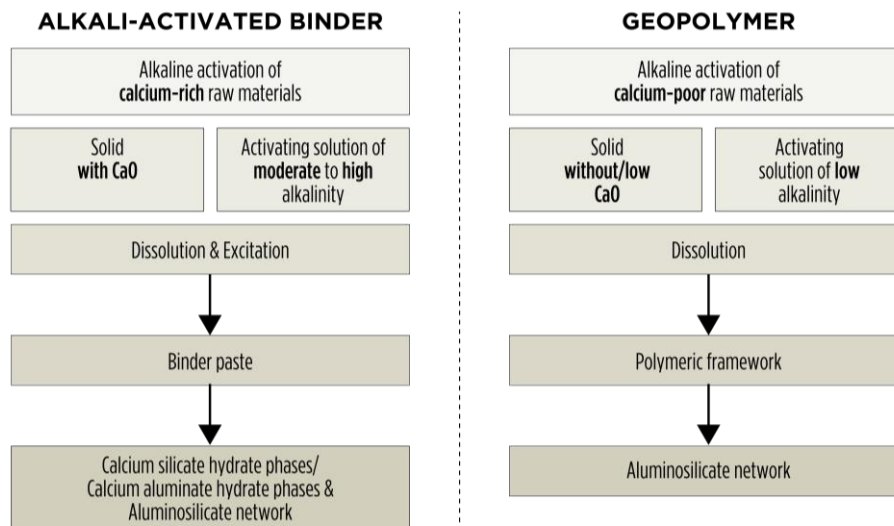

Figure 23.1 – Contrasting Reaction Processed for AAM’s and Geopolymers (after Vishojit Bahadur Thapa and Daniele Waldmann, ‘A short review on alkali activated binders and geopolymer binders’)

Unquestionably, the term ‘Geopolymer’ has become the most commonly used term for the whole suite of AAM’s – particularly in Australia which presently leads the world in AAM research and application.

Much of the Australian work uses a combination of granulated blast furnace slag and (Class ‘F’) fly ash as the base materials for AAM/‘Geopolymer’ products, with activation typically by a combination of sodium hydroxide and sodium silicate. In the conventional sense, a separate ‘binder’ is not added to the concrete mix. The base and activator materials comprising the binder, along with the aggregates and water, are charged into the concrete mixer and the materials are mixed together for an appropriate time. As with conventional concrete, the mixes are tested for slump and compressive strength and any other property of interest – generally using the same test methods as for conventional concrete.

While not being hugely different in appearance to ‘Portland’ cement concrete, there are generally some defining characteristics of AAM/‘Geopolymer’ concrete including:

- The ‘paste’ is of lower viscosity and the mix can appear to be quite ‘bony’;
- Typically, the water:binder ratio will be lower (about or below 0.3);
- The mix will respond very well to vibration when compacting;
- A final finish will be more difficult to achieve (due to lower ‘paste’ viscosity);
- The slump will be more sensitive to water addition;
- The concrete will respond very well to heat in terms of the rate of strength development.

While the AAM/‘Geopolymer’ concrete has some differences to conventional concrete, none of these are insurmountable as

demonstrated by the demanding commercial uses to date.

3.1 COMMERCIAL USES OF GEOPOLYMERS

A number of companies in Australia have initiated the commercial use of concrete products using alternative binders and that they have invariably called (and patented as) 'Geopolymer' concrete.

Rocla and Zeobond were two of the initial pioneers of commercial 'geopolymer' concrete in Australia. More recently, the Wagner Group in Queensland have used their 'Geopolymer' product [known commercially as *Earth Friendly Concrete (EFC)*] in two significant projects (as well as other less well-known applications).

EFC was used for the construction of precast floor panels that were used in the construction of the Global Change Institute building at the University of Queensland. These panels (**Figure 23.2**) were found, after testing, to meet the performance requirements of AS 3600 and were thus able to be used in this structure.



Figure 23.2 – 'Geopolymer' Precast Floor Panels used in Global Change Institute, University of QLD

EFC was also used in over 40,000 m³ of concrete in the construction of the Wellcamp (Brisbane West) Airport near Toowoomba in Queensland. This concrete was not used for runways but was used for other aircraft taxiway pavement and more generally for tilt panels, culverts and kerbs (**Figure 23.3**).

4 SULFATE ACTIVATED BINDERS

In the previous section, alkali activation of granulated blast furnace slag (slag) was discussed. Slag is a versatile material and it has been well understood for decades that it can also be very successfully activated using sulfates (e.g. gypsum, sodium or potassium sulfate). Binders that employ this activation are sometimes known as 'super-sulfated cements'.



Figure 23.3 – 'Geopolymer' Concrete Use – Aircraft Pavement and General Building – Wellcamp Airport

With these cements, the sulfate ion initiates the hydration of slag leading to the formation of calcium silicate hydrate and ettringite. Generally, a small proportion of 'Portland' cement is also added to the binder to provide improved early-age strength.

As no calcination or kiln firing is required, super-sulfated cements have low embodied CO₂ levels and low embodied energy and are much more environment-friendly than 'Portland' cement. The hydration reaction gives low levels of exothermic reaction and heat production, so these cements are considered to be low-heat types. The resultant concrete results in good strength performance and good durability performance, particularly in terms of resistance to attack by sulfate ions. Excellent drying shrinkage performance is also claimed with this concrete.

One unusual area where sulfate activation of slag is seen is in producing mine backfill in metalliferous mines where sulfur-containing ores are mined. When slag is used as a cementitious material to produce the low-strength backfill, some quite exceptional strengths (early and later-age) are obtained

with low binder contents due to activation of the slag by the high levels of sulfate in the mine wastes used in the manufacture of the backfill.

4.1 COMMERCIAL USES OF *ENVISIA*TM

In the commercial world, the use of super-sulfate cements in Australia has been limited until recently. Boral has produced a concrete product known as *Envisia*TM which uses sulfate-activated slag as the main part of the binder material. *Envisia*TM concrete has been used on major projects in both Sydney and Melbourne, including the Barangaroo complex and Punchbowl Mosque in Sydney and the Stokehouse in Melbourne (**Figure 23.4**). The benefits claimed from using *Envisia*TM include all of those described above, but most particularly its low CO₂ and embodied energy, its durability performance and its low shrinkage characteristic.



Figure 23.4 – The Stokehouse (Melbourne) was constructed using *Envisia*TM Concrete

5 OTHER NOVEL PROCESSES

The above binder types and processes are modified versions of the existing processes used to make conventional ‘Portland’ cement concrete. There is research being undertaken that uses significantly different processes to produce structural products. Several are discussed below.

5.1 ‘CARBICRETE’

Carbicrete is a process developed in Canada in which concrete is produced using ‘wastes and CO₂’. The process uses ground granulated slag to replace ‘Portland’ cement and then

injects CO₂ to ‘cure’ the concrete. In this process, it is claimed that CO₂ production is avoided through using no cement, and that CO₂ can be taken from other sources for use as a curing agent, thus doubling up on its overall CO₂ reduction potential. The process is said to involve the injection of CO₂ into a concrete mix containing ground slag – where the CO₂ and calcium silicate in the slag react to form calcium carbonate which is the binding material. When used in block-making, it is claimed that, as well as being a net consumer of CO₂, the blocks have strengths about 50% higher than conventional blocks.

To date, there has been no commercial production of blocks using this technology. The owners of the technology are intending to build a demonstration plant and then try to sell the technology to others.

5.2 ‘SOLIDIA’

This technology is another CO₂-cured concrete system (as is another similar process called *CarbonCure*) that also includes the use of a modified cement type that creates lower levels of CO₂ emissions up-front. The claim is that overall, about a 70% reduction in CO₂ emissions relative to conventional ‘Portland’ cement use is possible with this technology, as well as reduced water use in concrete making. Like most of the CO₂ cured processes, they are able to be applied readily to the production of concrete products (e.g. bricks and blocks) but to date have limited application in premixed concrete. This company is working with a major concrete producer to remedy this weakness and has claimed some success. The further complication in moving from bricks/blocks to premixed concrete is the need to be able to meet well-established requirements in Standards and specifications. This is a challenge for all new technologies (see sub-section 6 below).

5.3 MAGNESIUM OXYCHLORIDE CEMENT

Magnesium oxychloride cement (MOC) is produced from magnesium mining wastes which include magnesium oxide and magnesium chloride components which may also be obtained from seawater. MOC has demonstrated good compressive strength performance but suffers from a number of performance weaknesses that have limited its use. These weaknesses include (a) relatively poor resistance to water ingress and (b) issues related to corrosion resistance of embedded steel which may be a consequence of the presence of high levels of chloride ion.

5.4 ACTIVATION OF MINERAL-BASED MATERIALS

Given the constraints on fly ash and slag availability as noted in sub-section 2, more substantial sources of the base materials have been considered. One of these materials is meta-kaolin, an anhydrous, calcined form of the clay material kaolinite. If kaolinite is heated in a kiln at about 600-800°C, it becomes a highly pozzolanic and reactive material. It has been used as a pozzolan in conventional concrete and has also been used as a base material in AAM's.

While much of the work on meta-kaolin to date has been done with quite pure clay, test work has also shown that quite impure clay materials containing kaolin, once activated, can still be quite efficient pozzolans and base materials for AAM's.

It is obvious that the availability of clay materials world-wide is much greater than that of fly ash and slag which suggests these mineral materials may provide more viable base materials for the production of alternative binders.

6. ISSUES WHEN ADOPTING ALTERNATIVE BINDER TECHNOLOGIES

Given the relatively long history of use of 'Portland' cement based concrete and its universal adoption, it is probably no surprise that any new cement or concrete technology will need to prove that it reliably produces products with effectively equivalent performance to the conventional materials and also at competitive cost. These two issues are the primary 'hurdles' that need to be overcome for any alternative binder technologies. In addition, protocols need to be established to calculate the embodied CO₂ levels in these materials in a standardised way so that proper comparisons between different alternative binder types and with 'Portland' cement can be made.

Standards – Given the amount of research being carried out internationally on alkali activated material (AAM) binders, it is not surprising that this group of materials has come to the attention of those seeking to standardise the composition and/or testing requirements for both the binders and the resultant concrete. In Europe, RILEM committees have been established to (a) develop performance-based specifications and make recommendations for the development of Standards, and (b) make recommendations regarding appropriate test methodologies and protocols for the analysis of the durability of AAM binders and mortars and concretes made with the AAM binders.

(NOTE: RILEM is the International Union of Laboratories and Experts in Construction Materials, Systems and Structures.)

In Australia, there is no Australian Standard applicable to AAM binders or concrete, however Standards Australia are currently developing a Handbook to cover AAM's and Geopolymers. In addition, some State Government bodies (e.g. VicRoads and QTMR in Victoria and Queensland respectively) have published specifications for 'Geopolymer' concretes. These are not for use for structural purposes, but rather for footpaths, noise barriers, Jersey barriers etc.

The current lack of accepted Standards means that there is reluctance by specifiers, designers

and builders to use the new materials in structures with high risk profiles (e.g. high-rise buildings, bridges etc.)

Cost – Despite the use of (nominal) ‘wastes’ as part of the formulation in most of the alternative materials, their cost is still often higher than the conventional concrete alternative. The activator materials are expensive, and at present relatively low volumes of alternative products are being manufactured. Without incentives or a tax system that penalises CO₂ emissions, cost will be an ongoing prohibitive factor limiting their adoption.

Embodied CO₂ Calculations – The primary reason for investigating or using alternative binder materials is their lower embodied CO₂ levels. Currently, researchers and producers involved with alternative binders are able to make claims about levels of CO₂ reduction relative to ‘Portland’ cement without reference to a standardised method. As these claims will have both technical and commercial implications, an accepted, common calculation methodology will be required.

With any new technology comes the need to integrate it into common use, and where the incumbent technology is well established, this can be problematic. For alternative binders, the main issues are (a) lack of standardisation, (b) cost and (c) the lack of a yardstick by which to measure embodied CO₂ levels. Considerable work is being done internationally on standardisation of specifications and test methods for alternative binder materials and concrete and this should assist in reducing one of the major acceptance hurdles for these products.

7. SUMMARY

The primary reason that alternative binders that might replace ‘Portland’ cement are being sought is to try to reduce the levels of embodied energy and embodied CO₂ in concrete. A huge amount of research in this area has been underway for at least a decade and while there have been some commercial applications of, for example, concrete using AAM and super-sulfated binders, it has been minimal. Most of these technologies involve alkali activation of fly ash and slag and it has been shown that even if all of the available fly ash and slag being produced in the world was used for binder production, it would not go close to being a practical option for complete ‘Portland’ cement replacement.

While many of the newer binder technologies being trialled still rely on fly ash and slag, it has been shown that some mineral materials can be activated at quite low temperatures and be used in both conventional and alternative binder scenarios.

8. RELEVANT AUSTRALIAN STANDARDS AND SPECIFICATIONS

- 1) AS 3600 – *Concrete structures*
- 2) QTMR Specification MRTS270 – *Precast Geopolymer Concrete Elements* (November 2018)
- 3) VicRoads Section 703 – *Geopolymer Concrete – General Concrete Paving*

9. REFERENCES

- 1) Concrete Institute of Australia Recommended Practice Z16, '*Geopolymer Concrete*'
 - 2) RILEM TC224-AAM State-of-the-Art Report, '*Alkali Activated Materials*'
 - 3) Bligh, R. and Glasby T. (2013), '*Development of geopolymer precast floor panels for the Global Change Institute at University of Queensland*', Proceedings Concrete Institute of Australia Biennial Conference, Concrete 2013 – Understanding Concrete, Gold Coast, Australia
 - 4) Glasby, T. et al (2015), '*EFC geopolymer concrete aircraft pavements at Brisbane West Wellcamp Airport*', Proceedings Concrete Institute of Australia Biennial Conference, Concrete 2015, Melbourne, Australia
 - 5) Chandler, J. et al, (2013) '*Development and commercialisation of low carbon, low shrinkage, highly durable Envisia® concrete*', Proceedings Concrete Institute of Australia Biennial Conference, Concrete 2013 – Understanding Concrete, Gold Coast, Australia
-

This section considers areas of concrete technology that will take both concrete as a material and concrete construction into the future. Concrete has evolved from the basic material developed in the 1800's, and if anything, the rate of expansion of concrete technology is increasing in line with (a) demands for improved performance, and (b) the growth of technology generally.

CONTENTS

1. INTRODUCTION	2
2. PIVOTAL DEVELOPMENTS IN CONCRETE TECHNOLOGY	2
2.1 STEEL REINFORCING	2
2.2 CONCRETE ADMIXTURES	3
3. CONCRETE TECHNOLOGIES FOR THE FUTURE	3
3.1.SELF-COMPACTING CONCRETE (SCC) OR SUPER WORKABLE CONCRETE (SWC).....	4
3.2 FIBRE REINFORCED CONCRETE (FRC)	4
3.3 ULTRA-HIGH STRENGTH / ULTRA-HIGH-PERFORMANCE CONCRETE (UHPC)	4
3.4 POLYMER CONCRETE	5
3.5 PERVIOUS CONCRETE	5
3.6 SELF-HEALING CONCRETE	6
3.7 SELF-CURING CONCRETE.....	6
3.8 TRANSLUCENT CONCRETE.....	7
3.9 GRAPHIC CONCRETE	7
3.10 3-D CONCRETE PRINTING	8
4. SUMMARY	10

1. INTRODUCTION

While the Romans were excellent exponents of concrete technology, and examples of their use of concrete persist to this day, the reality is that concrete technology did not develop continuously from that point, and in fact went into 'hibernation' until about the time of the Industrial Revolution. With the Industrial Revolution came the need for bigger, better and more durable buildings to support the investment required in new factories, as well as the need to provide reliable infrastructure for

railways, shipping and other transport modes needed in this period of growth. Ease of construction and improved durability were two of the primary necessities. After a period of development in the late 1700's and early 1800's, 'Portland' cement and concrete as we now know it became a reality. Development of concrete technology has been 'non-stop' since then.

2. PIVOTAL DEVELOPMENTS IN CONCRETE TECHNOLOGY

There have been a few pivotal developments in concrete technology that have led to more wide-ranging applications of concrete and which have formed the basis for the expanded use of the material in a huge array of applications. Concrete technology has been supported by excellent research that has been carried out in many countries leading to an in-depth understanding of concrete performance. One of the advantages here has been the 'universal' nature of 'Portland' cement concrete. No matter where it is made in the world it is based on the same fundamental technology which has meant that effectively all research has been useful in increasing the understanding of the nature and performance of the material.

Two fundamental development areas that have made concrete into the high performing, versatile material that it is now are (a) use of steel reinforcing, and (b) admixture development.

2.1 STEEL REINFORCING

(The sub-section provides a brief development history of concrete reinforcing-prestressing and can be regarded as supplementary information for Part I, Part II-Section 6 and Part V-Section 11 of this Guide.)

While concrete is well known for its high compressive strength, it is also known as a

brittle material of low ductility. Used alone, concrete would not have become the highly sophisticated and versatile building material that it is now. It is the combination of concrete and steel reinforcing, based on the inherent compatibility of the two materials that has expanded the range of uses of modern concrete.

Reinforced concrete was developed initially in France and England in the mid-1800's and used in some quite simple construction including making flower-pots and for domestic dwellings. In the late-1800's a German firm used reinforced concrete widely leading to an increased understanding of reinforced concrete applications. Then in the early-1900's, reinforced concrete started to gain traction in the USA with it being used in bridge construction, in an aesthetic application (a bell tower in San Francisco which survived the 1906 earthquake) and, in 1904 for the first 'skyscraper' – the 16-storey Ingalls Building in Cincinnati. This was followed quickly by a number of similar high-rise constructions in Los Angeles. It was the 1906 San Francisco earthquake and the need for more resilient buildings that increased interest in concrete construction due to its relatively high strength and the fire resistance of the material.

Today reinforced concrete, particularly through newer approaches to reinforcing (e.g. post-tensioned applications including bridges and floors in high-rise commercial structures), is widely used and has further extended the scope of structural applications of concrete.

It should be noted however, that steel embedded in concrete will lead, ultimately, to the destruction of that concrete after steel corrosion begins. Through either carbonation or ingress of chloride ions, embedded steel will ultimately corrode unless some electrochemical protection is applied to prevent or reverse any active corrosion. It is often stated that modern concrete is a lesser product than (say) Roman concrete, with the example of the Pantheon in Rome being given as a concrete structure that has lasted, in pristine condition, for 2,000 years. It is notable that this structure contains no steel (or metal) reinforcement.

2.2 CONCRETE ADMIXTURES

While very basic admixtures were used even by the Romans (e.g. blood as an air entraining admixture), it has been the development of modern concrete admixtures that began in about the 1930's and accelerated towards the year 2000, that has taken concrete into new paradigms. In their earliest versions, concrete admixtures were confined to simple air-entrainers, retarders, accelerators and water-reducers. Modern admixtures allow a huge range of concrete performance characteristics to be managed, including very high strength concrete of excellent workability that can be produced, pumped and placed; concrete that can be placed underwater; concrete that can be 'put to sleep' for up to 3 days and then 'woken up' and applied to a substrate achieving high strengths very quickly; concrete where the workability can be managed for extended periods in high temperature environments without unreasonably delaying setting time. Concrete admixtures can also now be 'tailored' to achieve certain performance outcomes using PCE technology (see Section 5 'Admixtures').

Admixture use forms the basis of many modern concrete applications.

3. CONCRETE TECHNOLOGIES FOR THE FUTURE

Like all other modern technologies, developments in concrete technology are increasing (a) as general science and engineering evolve, and (b) in response to increased performance requirements (to enhance both engineering and environmental performance) from industry and the community. In the following, several of the newest approaches to improving and expanding concrete applications are discussed.

3.2 SELF-COMPACTING CONCRETE (SCC) OR SUPER WORKABLE CONCRETE (SWC)

While SCC/SWC has been in use for some years, it is the range of applications and the likelihood that SCC/SWC will become the new 'norm' for many concrete applications that has it included in this review.

SCC/SWC is becoming more widely used as demand increases for very high strength concrete in both precast and pre-mix applications that (a) is stable with respect to segregation risk, (b) is able to be pumped in (very) high-rise structures, (c) is able to produce high quality off-form finishes, (d) is (more) easily placed in elements with highly congested reinforcement, and (e) reduces manpower requirements for placing and finishing.

As with any high-performance material being used in demanding applications, it is imperative that the use of SCC/SWC be trialled for any project for which it is being considered as there is a large range of performance properties able to be achieved with this product type and these need to be assessed against the needs for each potential project.

(For more information about SCC/SWC, refer to Part VI-Section 22 of this Guide.)

3.3 FIBRE REINFORCED CONCRETE (FRC)

FRC in its simplest forms has been used in the concrete industry for many years. However, the basic applications of steel or plastic fibres for control of cracking or improved tensile performance and abrasion resistance are now being extended by the use of specialised fibre and material types.

In the USA, a 'bendable' concrete has been developed. This is a relatively light-weight concrete that uses very fine silica sand in its formulation, as well as coated PVA fibres. When load is applied to a concrete element using this technology, the lubricated fibres allow the concrete to bend rather than break (i.e. they increase its ductility). This technology

is useful in seismic areas and has been applied in high-rise buildings in Tokyo, Japan.

In related research, carbon nano-tubes (synthetic carbon 'tubes' of about 5-60 nm diameter and 5-30 µm length) have been added in low proportion to cementitious materials with resultant increases in compressive and tensile strengths and improved paste microstructure.

(For more information about fibre reinforced concrete, refer to Part I, Part II-Section 7 and Part V-Section 11 of this Guide.)

3.4 ULTRA-HIGH STRENGTH / ULTRA-HIGH-PERFORMANCE CONCRETE (UHPC)

UHPC has been developed and applied in many countries, with the USA leading the way in many applications. With compressive strengths in the order of 200 MPa and tensile strengths in the order of 10 MPa, this type of concrete is being used in bridge construction (for girders and decks and seismic retrofits), in precast applications and in security/blast mitigation applications.

UHPC, by its very nature, is expected to have at least a 100-year design life and to be highly durable and relatively very resistant to penetration by chloride ions, to freeze-thaw attack and to carbonation and has very high abrasion resistance. These characteristics make it an ideal (albeit initially expensive) concrete material for use in bridges in regions where snow and ice are common, and salt-based materials are used for management of ice build-up.

UHPC is produced from a mixture of powdered cementitious materials (cement plus silica fume), other inert powders, super-plasticising admixtures, water (with a W/C ratio generally <0.2) and (steel, synthetic or natural) fibres. Mixing of the UHPC is a prolonged process, but given the fineness of the components, is fundamental to its success. Nanoparticles have also been used to further enhance the performance of UHPC.

3.4 POLYMER CONCRETE

Polymer concretes can (a) use thermoplastic polymers or thermo-setting resins as replacements for cement in a concrete mix, or (b) use polymeric materials in combination with cement as a binder in Polymer Cement Concrete or Polymer Modified Concrete.

When manufacturing polymer concrete with polymer only as the binder, the resin content is typically in the range of 10-20% by mass of the concrete – the actual proportion used depends on the nature and size of the aggregates and the concrete strength required. No water is used in these particular mixes. With the range of polymer types available and varying proportions of polymer that can be used when making Polymer Cement Concrete, a wide range of concrete performance properties is possible.

The use of polymeric binders has several effects, including (a) increased cost, (b) good compressive strength performance, (c) improved tensile strength performance, (d) low permeability and resistance to water penetration, (e) good adhesion to a range of other materials, (f) good freeze-thaw resistance and (g) lighter weight concrete that is readily compacted by vibration.

With increasing demands for high durability performance for some concrete applications and some reduction in cost of polymer materials, there is an increasing interest in 'polymer concrete' in specialised applications like sewerage systems, in concrete repair and for the construction of smooth concrete surfacing.

3.5 PERVIOUS CONCRETE

Pervious or permeable concrete allows water to run through it rather than run over it as would be the case in conventional slab or pavement applications (**Figure 24.1**). With conventional concrete use in open-space environments (e.g. car parks at shopping centres, council paths and airports) there can be significant run-off and potential flooding issues associated with any reasonable rainfall event. With pervious or absorbent concrete, the water can run through

the concrete and be directed to flood control systems located beneath the concrete. This has both functional and environmental advantages.

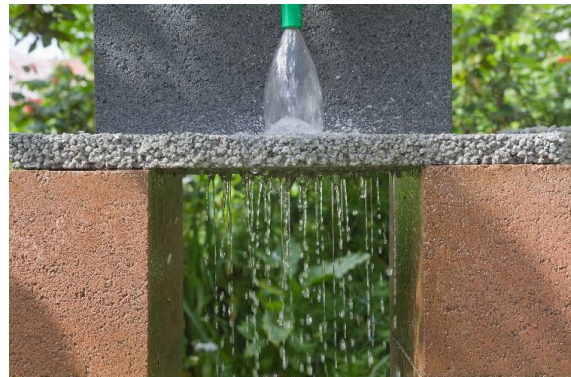

Figures 24.1 – A Permeable Paver Demonstration, Austin's Ferry, Tasmania, Australia^{24.1}

Pervious or absorbent concrete is effectively a no-fines concrete where the sand is omitted from the mix design. This creates a coarse aggregate mix where the paste adheres to the coarse aggregate and binds it together, while leaving voids between the coarse aggregate particles that allow water to easily penetrate the concrete. Typically, a single-sized aggregate is used – usually either 20 mm, 14 mm or 10 mm – and no aggregate material <5 mm or flaky or elongated aggregate should be present in the mix. Final strength is dependent on the cement content and water/cement ratio. Increasing the paste volume (water + cement) will reduce the permeability. Water demand can be very tricky and too much water can affect placing and final performance characteristics. There is no workability test as such for this concrete. The concrete should not be subjected to compaction, except possibly rodding around the edges of formwork or penetrations and specialised rollers where placing pavement. The concrete should be placed quite quickly as it has a tendency to dry out easily. Effective curing of the exposed surfaces of this product generally requires barriers such as covering in plastic film.

While this type of concrete is suited to the purpose intended (for example, as in **Figure 24.2**), and for the particular environments indicated, concerns have been raised about the general performance and

durability of pervious/absorbent concrete. This has limited its applications by some specifying authorities and in some geographical regions. There is concern, for example, about the freeze-thaw resistance of this type of concrete. In temperate and tropical regions this does not create an issue, but in cooler climates it would be a problem.



Figure 24.2 – Porous Concrete Pavement in the Middle Strip of Two Parallel Concrete Pavements^{24.2}

3.6 SELF-HEALING CONCRETE

One of the realities regarding concrete is that it can crack for a variety of reasons. Generally, this is anticipated in the design phase for a new structure and accommodations are made to ensure that any cracking does not unduly influence the life or performance of the structure.

Recently, self-healing concretes have been developed. These concrete products will react to water ingress into the concrete from any crack that has formed by initiating a reaction that forms a product that will seal the crack(s) (see **Figure 24.3**). This type of reaction can be by one of several mechanisms.

In a more conventional approach, the concrete mix can contain either (a) 'hydro-gels' or (b) capsules of polymeric materials that break when and where the concrete cracks. In both cases, the hydro-gel or the polymeric material from the capsule reacts with the water that has entered the concrete and swells, thus sealing the crack.

In a less conventional approach, the concrete as manufactured contains a type of bacteria that, when it comes into contact with air and

water, reacts with lime (from cement hydration) to form limestone (or calcite) that can seal the crack.

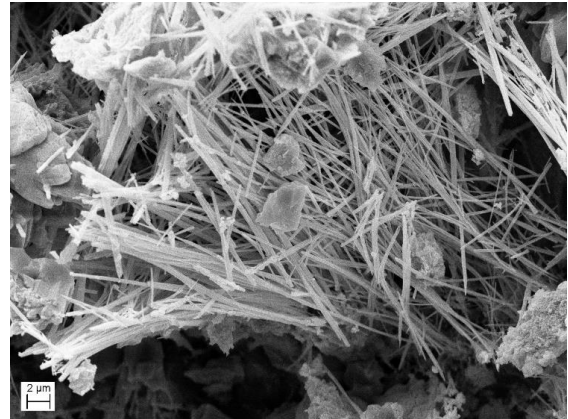

Figure 24.3 – A SEM Image showing the Formation of a Crack Bridging for Self-healing in Concrete^{24.3}

It should be noted that these approaches to 'healing' cracks cannot be retro-fitted and the materials – polymers or bacteria – need to be included in the original concrete mix.

3.7 SELF-CURING CONCRETE

There is no real debate about the importance of curing concrete to ensure that the best strength and durability performance is obtained from a given concrete mix. There is also no debate that, in many cases, curing is ignored in most concrete construction projects.

Another concern in modern concretes, with respect to ensuring expected strength and durability performance is achieved, is that (a) the prevalence of low water/cement ratios (say <0.35) and (b) the use of silica fume in high-performance concretes, increase the risk of self-desiccation of the concrete which can lead to increased autogenous shrinkage. In these situations, a process which allows the concrete to be 'self-curing' is advantageous. For low W/C ratio mixes, it is also the case that the application of external water curing is likely to be a less effective curing method because of the low porosity and permeability of the resulting concrete.

In the process of self-curing, either (a) water is added to the concrete from internal sources (e.g. saturated porous aggregates), or (b)

water is retained within the concrete by using chemicals that prevent or limit water loss by evaporation.

The use of saturated, lightweight aggregates allows the exchange of water between the aggregate particles and the 'cement paste' in both the plastic and hardened states of concrete. It is the exchange in the hardened state that promotes ongoing curing. These aggregates may be natural or synthetic and examples include scoria and expanded shales. In some cases, the outer surface of the aggregate material has some pozzolanic characteristics and this further contributes to strength improvement when using these special aggregates.

The chemicals added to the mix to promote internal curing include polyethylene glycols of various molecular weights and other polymeric materials. These compounds form hydrogen bonds with water molecules in the 'cement paste' which lead to a reduction in water vapour pressure and reduced evaporation rates – leaving more water in the paste for ongoing hydration reactions as indicated by increased compressive strength in concrete using these particular additives.

3.8 TRANSLUCENT CONCRETE

Concrete is typically a solid mass and provides a rigid barrier to heat and sound transmission, and of course, to light transmission. Or at least that was the case until recently.

There have been two approaches used to making concrete translucent (**Figure 24.4**) – that is, allowing a degree of light penetration through the 'solid' concrete.

In one form of translucent concrete, optical fibres are included in the concrete mix and these are able to align to a sufficient degree to allow some light to be passed through the concrete – sufficient to allow an object on one side of the (say) wall to be seen in outline from the other side.

In another version, translucent fabric is cast layer by layer in the concrete. The final product shows no detriment to strength or durability performance but allows a degree of visibility of

forms and even colours to be passed through the concrete structure. The fibres in the fabric are very fine and the proportion of fabric to concrete is low which accounts for the minimal impact on the physical performance of the concrete.



Figure 24.4 – Translucent Concrete Booth at Expo Bau 2011 in Munich, Germany^{24.4}

In a similar development, a cement that can emit light has been developed. It would appear that the cement/concrete contains a phosphorescent chemical that absorbs light during the daylight hours and then emits light once the sun goes down. The suggestion is that it would be useful for paths and on bridge surfaces to improve user safety in these situations.

3.9 GRAPHIC CONCRETE

Graphic concrete involves the creation of complex images on the surface of concrete, particularly for precast wall applications (**Figures 24.5** and **24.6**). The primary use is in architectural finishes and the creation of murals for a variety of purposes. There are a couple of different methods for producing these types of surfaces.

In one system, the precise application of retarders to the surface of concrete form liners is used to create contrasting surface finishes – most particularly between 'smooth' concrete surfaces and exposed fine aggregate surfaces.

For more information see: www.graphicconcrete.com



Figure 24.5 – Artwork created on Concrete Walls of Hämeenlinna Provincial Archive, Finland^{24.5}

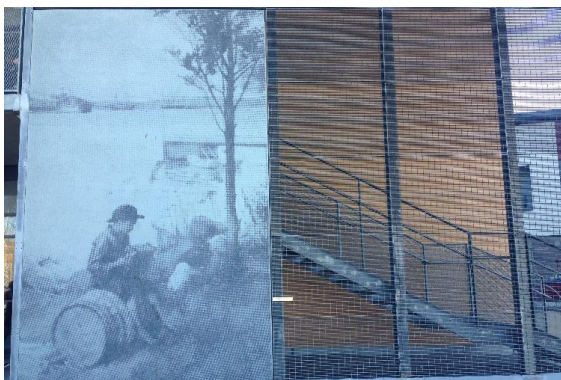

Figure 24.6 – Artwork created on a Precast Concrete Wall^{24.6}

In another system, thermochromatic pigments are combined in a concrete mix and, along with the use of wire heating technology and microprocessor control, changing images and colour-changing patterns can be manipulated in the surface of the concrete element. For more information see: www.chromastone.com

3.10 3-D CONCRETE PRINTING

Perhaps one of the most exciting and useful developments in concrete technology is the potential use of 3-D printing to create useful concrete structures like housing and bridges, and in reality, any other type or style of structure that can be produced by this process.

The basis of 3-D printing is the interaction of robotics (and other mechanical systems) and concrete technology to produce structures without any (or with very little) manual intervention. Arguably, any design that can be

converted into a computer file and loaded into a computer-controlled robot can be created – provided the concrete-related issues can be controlled. To date there has been huge interest in this technology from the military, from space agencies and from commercial companies to try to implement the technology in their respective areas.

(NOTE: 3-D printing has been widely and successfully used in other applications, particularly in creating medical prostheses, and its applications in these ‘soft’ applications are growing. Concrete, having a finite plastic life and being required to create high strength/durability structures, provides some different and interesting challenges.)

3-D printing involves the creation of walls and elements using layering of ‘concrete’ that eventually grow into the final structure (**Figure 24.7**). Complexities that are being grappled with include the use of coarse aggregate materials to provide strength; the bonding between successive layers in the structure and the means by which reinforcing might be used to provide improved strength performance.



Figure 24.7 – Robotics and 3-D Printing, Extrusion-based Technique^{24.7}

To date, 3-D printing has been used to create housing, public buildings, bridges and various structures that might be described as architectural or art-based (see **Figures 24.8** to **24.11**). This variety of structures is indicative of (a) the versatility of the process and (b) the wide-scale potential for use across the world, with a pertinent example being for the production of cheap but durable homes for people in poor countries or where some weather (or similar) event has caused widespread destruction.

If the amount of research on 3-D printing of concrete is any indicator, this technology will be at the forefront of concrete technology development for many years to come.

3-D printing does not follow the 'conventional' construction technology described in Part V of this Guide (i.e. handling and placing, compaction, finishing, curing, control of surface finish and control of cracking etc.). As the name implies, 3-D printing, also called 'additive manufacturing' or 'additive layered depositing', in general, is constructed by 'joining materials to make objects from 3-D model data, usually layer upon layer' (The American Society for Testing and Materials – ASTM). From this initial concept, 3-D printing has been developed into two major co-existing trends for concrete production, namely Extrusion-Based Techniques and Powder-Based Techniques:

- **The extrusion-based techniques**, also called 'continuous extrusion' and 'fused deposition modelling', relies on the consecutive extrusion and deposition of a (semi-liquid) paste/mortar/concrete mixture in a layer-upon-layer manner. The mixture is proportioned and mixed in advance, then is stored in a reservoir before being pumped to a printing head/nozzle (Figure 24.7).

An appropriate mix design to facilitate the extrusion-based techniques focuses on balancing two important yet somewhat contradicting requirements. On one hand, the mix must ensure sufficient workability, pump-ability without segregation; which reflects similar characteristics to self-compacting concrete (see 3.1). For this reason, a careful selection of aggregate sizes and shapes, along with other ingredients, must be conducted in relation to the chosen size and type of the printing nozzle. On the other hand, in the absence of formwork, the mix must ensure the stability (i.e. without heavy distortion) of extruded layers once they are placed. This is crucially important as each layer carries not only its self-weight but soon after it is placed, it will also support the 'dead loads' imposed by subsequent layers. This requirement normally

necessitates a mix design with a fast setting capacity and a high rate of strength gain. Equally importantly, without formwork protection, moisture loss and its effects on hydration and strength gain (discussed in Section 15), as well as other durability issues, need to be properly addressed.

- **The powder-based techniques**, also called 'binder jetting' or 'granular binding fabrication', sinter numerous layers of loose base powder by selectively depositing a specialised liquid (also known as 'ink') on each layer. The ink acts as a binding agent which also activates chemical reactions in the base powder. The final element is then dug out of the powder mass either by vibration or air blow. Although there is no practical limitation, the techniques have mostly been employed for small to medium scale structures with complicated compositions (Figures 24.10 and 24.11).



Figure 24.8 – 3-D Printed House, Extrusion-based Technique^{24.8}



Figure 24.9 – 3-D Printed Bridge, Extrusion-based Technique^{24.9}



Figure 24.10 – 3-D Printed Bridge, Powder-based Technique^{24.10}



Figure 24.11 – 3-D Sculpture, Powder-based Technique^{24.11}

4. SUMMARY

Concrete (as we know it) has had a life of about 200 years and although concrete technology is often seen as static and boring, the reality is that concrete has been developing and evolving as a material throughout its 200-year life. Modern concrete technology and the types of structures that are achievable would not have been contemplated 50 or even 30 years ago – such is the speed of development of the technology. This section has described some of the important advances of recent times and some of the (potential) improvements that will be made in the field of concrete technology over the next few years. It is likely however, that this section will be redundant much sooner than we might expect – such is the rate of change.

Of importance to the rate of change is the growing scope of concrete applications. The potential use of concrete by military and space agencies will likely see very high rates of change in the potential applications and the nature of the material as more challenging requirements are created by these new end-

users. For those who don't think concrete is boring – these are exciting times!

End Notes:

24.1 Photo adopted from 'A permeable paver demonstration, Austin's Ferry, Tasmania, Australia', by JJ Harrison, licensed under the Creative Commons Attribution-Share Alike 3.0 Unported license,

https://commons.wikimedia.org/wiki/File:Permeable_paver_demonstration.jpg

24.2 Photo adopted from Aaron Volkening, licensed under Creative Commons Attribution 2.0 Generic (CC BY 2.0),

<https://www.flickr.com/photos/87297882@N03/8071001110/in/photostream/>

24.3 Photo adopted from 'Concrete Crack Bridge for Self-Healing', by Department of Engineering, University of Cambridge, licensed under Creative Commons Attribution 2.0 Generic (CC BY 2.0),

<https://www.flickr.com/photos/cambridgeuniversity-engineering/14272521260>

24.4 Photo adopted from 'LUCEM Translucent Concrete booth at Expo Bau 2011', by Luxgineer, licensed under the Creative Commons Attribution-Share Alike 3.0 Unported license,

https://commons.wikimedia.org/wiki/File:LUCEM_Translucent_Concrete.jpg

24.5 Photo adopted from 'Hämeenlinnan maakunta-arkisto', by Kansallisarkisto, licensed under the Creative Commons Attribution 2.0 Generic license,

https://commons.wikimedia.org/wiki/File:H%C3%A4meenlinnan_maakunta-arkisto.jpg

24.6 Original art by Albert Edelfelt, photo by Zuissii, Public Domain license,

<https://commons.wikimedia.org/wiki/File:AETeos.jpg>

24.7 Screenshot adopted from 'Optimising 3D Concrete Printing', by 3TU.Bouw, licensed under Creative Commons Attribution-NoDerivs 3.0 Unported (CC BY-ND 3.0),

<https://vimeo.com/204877955>

24.8 Photo adopted from Marine Corps Systems Command, Public Domain license,

<https://www.marcorsyscom.marines.mil/Photos/igphoto/2001957675/>

^{24.9} Photo adopted from '*This is a detail of the first ever 3D printed bridge in the world*', by Marczoutendijk, licensed under Creative Commons Attribution-Share Alike 4.0 International license,
[https://commons.wikimedia.org/wiki/File:Detail_of_3D_printed_concrete_bicycle_bridge_in_Gemert_\(NL\).jpg](https://commons.wikimedia.org/wiki/File:Detail_of_3D_printed_concrete_bicycle_bridge_in_Gemert_(NL).jpg)

^{24.10} Photo adopted from '*The first structure of this type in the world*', by Institute for advance architecture of Catalonia, licensed under the Creative Commons Attribution-Share Alike 4.0 International license,
https://commons.wikimedia.org/wiki/File:3D_Printed_bridge.jpg

^{24.11} Photo adopted from '*A 3D printed sculpture made with D-Shape technology*', by D-Shape, licensed under the Creative Commons Attribution-Share Alike 4.0 International license,
https://commons.wikimedia.org/wiki/File:Radio_laria_d-shape.jpg

GUIDE TO CONCRETE CONSTRUCTION

T41



CEMENT CONCRETE
& AGGREGATES AUSTRALIA

PART VIII - Properties & Testing of Concrete

This Section describes how the various properties of concrete – in both the plastic (wet) and hardened (dry) states – are influenced by the materials from which concrete is made. Mention is also made of how the hardened-state properties are influenced by the concrete's treatment while it is plastic and while it is hardening – i.e. by its handling (on-site movement), placing, compacting, finishing and curing. More detailed information on these influences is provided in the Sections devoted to those particular topics (in Part V of this Guide).

CONTENTS

1. INTRODUCTION.....	2
2. PLASTIC STATE PROPERTIES.....	2
2.1 WORKABILITY	2
2.2 CONSISTENCY	3
2.3 COHESIVENESS.....	4
2.4 TEST METHODS	5
3. HARDENED STATE PROPERTIES.....	8
3.1 STRENGTH.....	8
3.2 DURABILITY.....	14
4. RELEVANT AUSTRALIAN STANDARDS	24
5. OTHER REFERENCES.....	24

1. INTRODUCTION

As outlined in the Introduction in this Guide, concrete is required to have certain, defined properties at two distinct stages, i.e. when it is in the initial plastic state and after it has hardened. The plastic-state properties determine the ease with which it can be placed and finished, and the hardened-state properties determine how well it will perform in the completed structure, and for how long. As might be expected, different plastic and hardened state properties may be required for different projects depending on (a) the concrete specification and the site conditions, and (b) the serviceability requirements of the project, respectively.

This Section provides discussion about the most important properties and the inter-relationship between many of them.

2. PLASTIC STATE PROPERTIES

2.1 WORKABILITY

General – There is no singular way of describing concrete workability. Arguably it refers to the ease with which a concrete mix can be compacted without the risk of segregation. However, the desired workability of a concrete mix will depend in part on what means of compaction are available as well as the type of concrete element being placed (e.g. the workability requirements for slip-form paving versus a high-strength column with congested reinforcement are vastly different).

When concrete is being compacted, work is applied to the mix to eliminate any entrapped air – until it is fully consolidated. This work needs to overcome the friction between particles as well as the friction between the mix and any adjacent surfaces (e.g. reinforcing, formwork) – called internal friction and surface friction respectively. It is only the ‘internal friction’ that is a function of the mix itself. Some work will also be wasted trying to consolidate already consolidated concrete – meaning that only ‘useful’ work (i.e. work actually involved in compaction) should be considered when assessing workability, which can be defined as ‘the amount of useful internal work necessary to produce full compaction’ [1]. The American Concrete Institute (ACI 116R-00) defines workability as ‘that property of freshly mixed concrete or mortar that determines the ease with which it can be mixed, placed, consolidated and finished to a homogenous condition’.

A number of mix components affect the degree of ‘internal friction’, as described below.

Influence of Water Content – For given proportions of cement and aggregates in a concrete mix, the higher the water content, the more workable the concrete will be. However,

increased water content will increase the water/cement ratio and thereby reduce strength and durability. It will also increase the risk of cracking caused by drying shrinkage (**Figure 25.1**). Normally, therefore, only very minor adjustments to workability should be made by the addition of water alone.

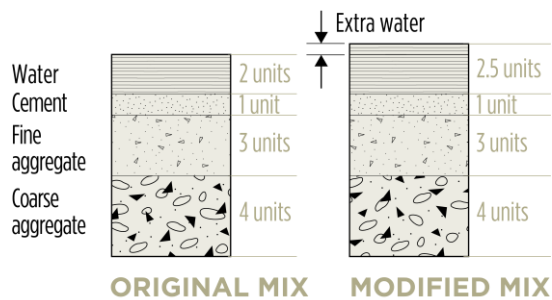

EFFECT	Water/cement ratio:	Increased
ADVANTAGE	Workability:	Increased
DISADVANTAGES	Strength and durability:	Decreased
	Shrinkage cracking:	Increased

Figure 25.1 – The Effects of Increased Water Content

Influence of Cement Content – Because the cement paste lubricates the aggregate particles when concrete is in the plastic state, the higher the cement content at a fixed water/cement ratio, the more workable the concrete will be. Therefore, adjustments to workability made by the addition of water should always be accompanied by an addition of cement to maintain the water/cement ratio (**Figure 25.2**).

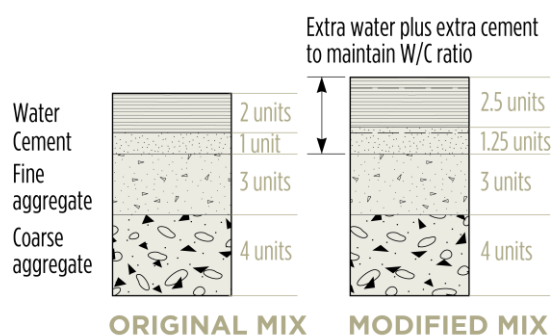

EFFECT	Water/cement ratio:	Same
ADVANTAGES	Workability:	Increased
	Strength and durability:	Same
	Shrinkage cracking:	Same

Figure 25.2 – The Effects of Increased Water and Cement Contents

Influence of Aggregate Particle Size Distribution (Grading)

– The combination of fine and coarse aggregates in the concrete mix provides a grading of particles from large to small, and a combined grading curve describes the proportion of aggregate of each particle size in a mix (see Part II, Section 3 of this Guide). The overall grading will affect workability because the amount of water (or paste) necessary to wet all the solids in the mix will depend on the surface area of the aggregates. Sieving (**Figure 25.3**) is used to determine the combined grading curve.



Figure 25.3 – Aggregate Combined Grading determined by Sieving

It is usual to aim for a smooth combined grading curve to achieve optimum workability. Nevertheless, within quite wide limits, a variety of aggregate gradings may be used satisfactorily.

Influence of Aggregate Particle Shape and Size

– The shape of the aggregate can have an effect on workability. For similar mix proportions, rounded or roughly cubically shaped aggregates will produce more workable concrete than that produced from flaky or elongated aggregate particles. A proportion of flaky or elongated particles is permissible but they will increase the amount of cement paste required to achieve the required workability. The maximum size of particles also has an effect – the larger the particle size, the greater the workability for a given cement content and water/cement ratio.

2.2 CONSISTENCY

‘Consistency’ is a term used to describe the ease with which concrete will flow and is often used to reflect the ‘degree of wetness’ of the

concrete. Although it is a different characteristic from workability, in practice the two terms are often confused and merged into one descriptor – the 'slump' of concrete.

This 'slump' term is derived from the standard test procedure for determining the consistency of concrete, known familiarly as the 'Slump Test', which is described generally in 2.4 and in more detail in Section 26.

In general, 'high' slump concretes are wetter than 'low' slump concretes and are more workable. However, concretes of the same slump can have varying degrees of workability.

Table 25.1 provides an indication of the appropriate slump for various construction elements.

Table 25.1 – Typical Ranges of Slump for Various Elements (except super-plasticised concrete)

Element	Typical range of slump (mm)
Mass concrete	30-80
Plain footings, caissons and substructure walls	50-80
Pavements and slabs	50-80
Beams	50-100
Reinforced footings	50-100
Columns	50-100
Reinforced walls	80-120

2.3 COHESIVENESS

General – The cohesiveness of concrete is a measure of its ability to resist segregation into its separate components during handling, placing and compacting.

Segregation can occur as the separation of coarse aggregates from the cement mortar, or as 'bleeding' –the displacement of water to the surface of the concrete as the heavy materials settle towards the bottom of the element. Bleeding generally occurs after compaction and bull floating and continues until the mix stiffens sufficiently to prevent further settling.

There are several factors that can affect the cohesiveness of concrete, as follows:

Influence of Specific Gravities of the Constituents – The typical specific gravities of materials in a normal- weight concrete mix are shown in **Table 25.2**.

Table 25.2 – Typical Material Specific Gravity Values

Material	Specific Gravity
Water	1.00
Fine aggregate	2.5-2.7
Coarse aggregate	2.5-3.0
Cement	3.15
Fly Ash	2.1-2.5
GGBFS	2.9

Jolting of the mix, or sudden changes of velocity and direction of the concrete during the placing operation can cause particles of different specific gravities to dislodge from the plastic mass. This is commonly referred to as 'segregation' and can result in honey-combed or 'boney' areas in compacted concrete. In flowing concretes, it can mean the separation of the mortar and aggregate components as the concrete flows within the forms (or in the Slump Flow Test as described in 2.4).

Influence of Consistency – The higher the water content in the mix (which usually means higher slump) the greater is the risk of segregation and bleeding occurring.

Adding water leads to thinning-out of the cement paste which reduces its capacity to hold aggregate particles apart during the handling and placing processes. In addition, a higher water content delays the stiffening of concrete during its very early life, allowing sedimentation of heavier particles in the mix to continue for a longer period resulting in more bleeding. Cold weather also retards stiffening/setting and allows bleeding to continue for a longer time.

Dry mixes, which can be friable, are also prone to segregation.

A very useful indication of the cohesiveness of concrete can be gained by lightly tapping the side of the slump-test specimen with the tamping rod after the slump measurement has been made (see 2.4). If the cone breaks up, the mix may be prone to segregation.

Influence of Aggregate Grading – Mixes that are deficient in very fine aggregate tend to segregate more readily during handling. Bleeding can also be increased due to a lack of fines. On the other hand, excessive fines (e.g. High-Volume Fly Ash Concrete, concrete containing silica fume) make the concrete 'sticky' and, although very cohesive, it will be difficult to move, place and compact.

In mixes where there is a deficiency in very fine particles, issues with excessive bleeding may be reduced by the use of air-entraining agents. The microscopic air bubbles act like a fine aggregate by increasing surface area which limits the movement of water to the surface (See Part II, Section 5 'Admixtures').

2.4 TEST METHODS

General – Procedures used for the testing of plastic concrete have been published by Standards Australia within the AS 1012 set of Standards. They range from procedures for sampling the fresh concrete to those for determining its consistency, setting times and other plastic properties. They are described in more detail in Section 26 of this Guide.

The strict application of standard procedures for testing concrete – both in the laboratory and the field – is of great importance. Such procedures are designed to eliminate, as far as possible, the operator-induced variability that may otherwise occur with test results. On construction sites, testing variability can result in a lower standard of quality control test results which may lead to unnecessary disputes about the quality of concrete and increased costs to all parties.

The Slump Test – The slump test is fully described in AS 1012.3.1. The equipment required to conduct the test is relatively simple. It comprises a Slump Cone – a mould (the hollow frustrum of a cone 200 mm in diameter

at the bottom, 100 mm diameter at the top, and 300 mm high) made of galvanised sheet metal and fitted with handles and foot-pieces; a steel tamping rod; a ruler; and auxiliary equipment such as a scoop, a steel tray and a container in which to collect the sample(s) to be tested.

The test is conducted by first obtaining a representative sample of the concrete to be tested. This should be done in accordance with AS 1012.1 if the concrete is to be sampled in the field; or AS 1012.2 if the test is to be done in a laboratory.

The slump cone is filled with the concrete to be tested in three approximately equal layers – each layer being rodded to compact it before the next layer is added. Surplus concrete is struck off the top of the mould before removing the mould from the concrete by lifting it slowly (in 3-4 seconds) and allowing the concrete to subside. The distance by which it subsides is then measured, with the result (expressed in mm) being reported as the slump value (**Figure 25.4**).

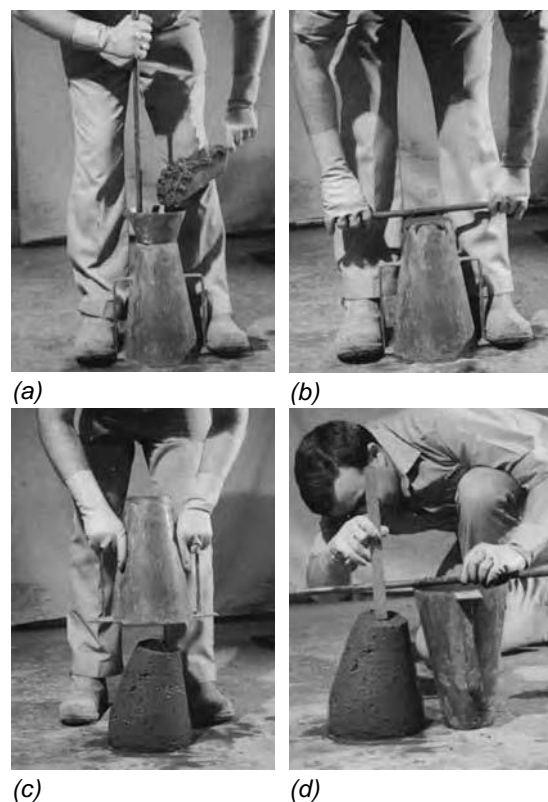
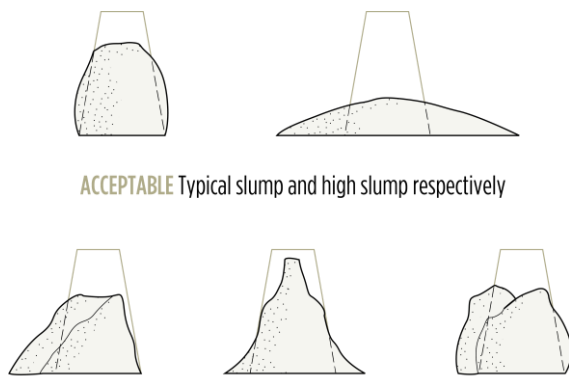

Figure 25.4 – The Slump Test (mould filling; surface struck-off; mould lifted; measure slump)

If, in subsiding, the concrete cone shears or collapses, the test should be repeated using a fresh portion of the sample (**Figure 25.5**). If on retest the concrete again shears or collapses, this fact should be recorded as it indicates a lack of cohesiveness in the mix.



ACCEPTABLE Typical slump and high slump respectively

NON-ACCEPTABLE, REPEAT TEST Shear failures (lateral collapse)

Figure 25.5 – Examples of ‘Slumped Concrete’ after Testing

The slump test has another important role to play in the control of concrete quality. Slump measurements taken from successive batches of the same concrete mix indicate whether a consistent product is being produced and provide an assessment of the degree of control being achieved during manufacture at the concrete plant.

Variations in slump for a given mix indicate that some changes have occurred in either the batching or mixing processes. While changes in water content (e.g. due to changes in aggregate moisture contents) are an obvious possible cause, other factors which affect workability (e.g. cement content, aggregate grading and particle shape) may also require investigation.

As slump testing is not very precise, AS 1379 allows some variation between measured slump and specified slump when testing slump at site. If measured slump varies by more than the allowed tolerance from the specified slump, that may be cause for rejection of the load from site. Note that the allowable variability increases as the slump value increases. In part this is due to the higher sensitivity of slump to water addition at the higher slump levels (**Table 25.3**).

Table 25.3 – Permissible Tolerances on Slump (AS 1379)^{25.1}

Specified Slump (mm)	Tolerance (mm)
< 60	±10
≥60 ≤80	±15
>80 ≤110	±20
>110 ≤150	±30
>150	±40

Gross batching errors will usually result in dramatic changes to the slump and should be readily apparent.

Compacting Factor Test – A test procedure described in AS 1012.3.2 is the Compacting Factor Test. Although not widely used in Australia, it provides a better measure of the workability of concrete than the slump test (which really measures consistency) and is better suited to controlling the production of low-slump concrete mixes.

The test measures the compaction achieved in a sample of concrete by performing a standard amount of work on it. The ‘standardised work’ component is achieved by allowing an ‘amount’ of concrete to fall (defined distances) from an upper sample hopper into a lower hopper and then into a cylindrical container (**Figure 25.6**). The ‘amount’ of concrete is such that the cylindrical container will be overfilled. After the excess concrete has been struck off, the mass of concrete in the cylinder is determined by weighing, and this portion of the sample is then discarded.



Figure 25.6 – The Compacting Factor Test Apparatus

A fresh portion of the test sample is then used to refill the cylinder, with the concrete on this occasion being fully compacted by rodding or by vibration. The mass of compacted concrete in the cylinder is determined by weighing.

The ratio of the mass of concrete contained in the cylinder partially compacted by the fall through the two cones to the mass contained in the cylinder when fully compacted is the Compacting Factor. The higher the Compacting Factor ratio, the more workable is the concrete.

The Vebe Test – The Vebe Test, also described in AS 1012.3.3, determines the consistency of concrete by measuring the time taken for a cone of concrete (moulded with a standard slump cone) to completely subside in a cylindrical mould under the action of vibration (**Figure 25.7**). The conditions of test are not unlike those experienced in the actual placement of concrete.



Figure 25.7 – The Vebe Test

The test is most useful in laboratory investigations, and particularly for very dry mixes. It is more sensitive to changes in material properties than the slump test. Indeed, it can be sensitive to changes in the early hydration rate of cements and is therefore not particularly suitable for controlling consistency in the field.

Workability Tests for Flowing Concrete – The (now) common use of flowing concrete mixes has led to the development of a number of ‘workability’ tests that are useful for the assessment of flowing or Self Compacting (SCC)

or Super Workable Concretes (SWC). Some of the tests that are in common use are:

- Slump Flow test;
- T-500 test;
- Visual Stability Index;
- L-Box; U-Box and J-Ring;
- Orimet Test Method.

While workability tests for flowing concrete are described more fully in Part VI, Section 22 and Part VIII, Section 26 of this Guide, a brief description of several is given below.

Slump Flow Test – The Slump Flow Test, also described in AS 1012.3.5, uses a standard slump cone. The slump cone is filled with the flowing concrete mix (no compaction step is necessary) and then lifted as is done in a normal slump test. Two measures of the flow characteristics of the concrete can be obtained from this test, namely (1) the final diameter of the concrete after flowing can be measured and the resultant ‘spread’ expressed in mm; and (2) using a marked ring at 500 mm diameter, the time taken from when the slump cone is lifted until the flowing concrete reaches the 500 mm line gives a value known as the T-500 value. For SCC or SWC, a typical ‘spread’ might be 600 mm; while a T-500 value of 2-10 seconds is typical (**Figure 25.8**).

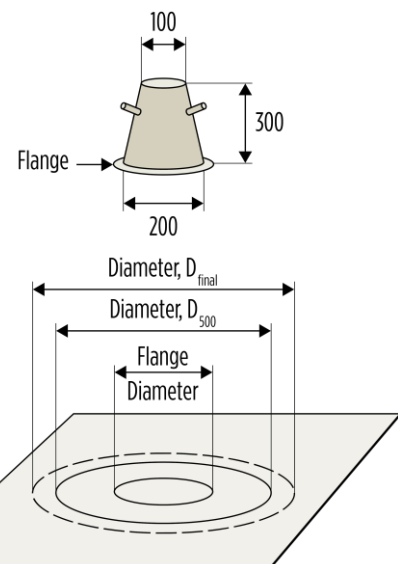

Figure 25.8 – Slump Flow Test (all dimensions are in millimetres)

Visual Stability Index (VSI) – The VSI, also described in ASTM C1611, is established by observing the presence or otherwise of bleed water at the leading edge of the concrete or if aggregate remains in the middle of the concrete sample after the Slump Flow Test. VSI values range for '0' for highly stable to '3' denoting unacceptable stability.

L-Box; U-Box and J-Ring Tests – These tests are used to measure the flow of a fluid concrete, under its own mass, through various types of impediments typical of what might be encountered as flowing concrete moves through congested reinforcement or around other components in a structure (Figures 25.9 and 25.10).

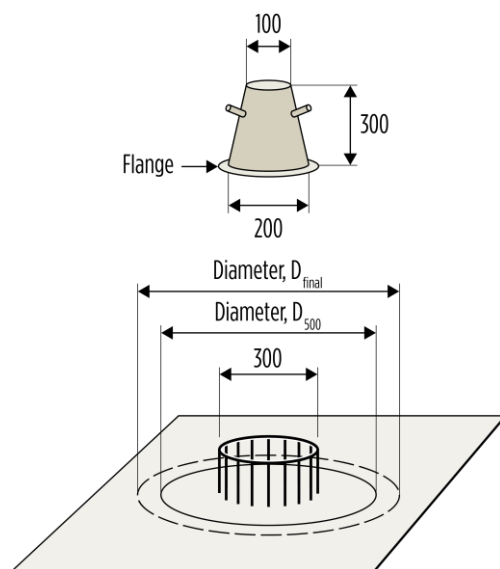

Figure 25.9 – Slump Flow and J-Ring Method (all dimensions are in millimetres)

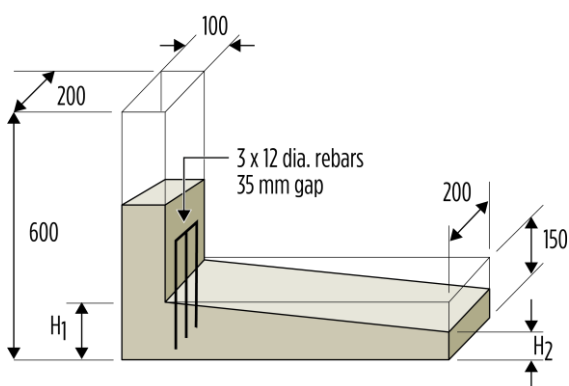

Figure 25.10 – L-Box Method (all dimensions are in millimetres)

Orimet Test Method – The Orimet test Method provides an indirect measure of the ability of a concrete to flow into a confined space under its own mass. The funnel is filled with concrete, and after the trapdoor is released, the time taken for the concrete to flow fully out of the funnel is determined and used as a measure of fluidity (Figure 25.11).

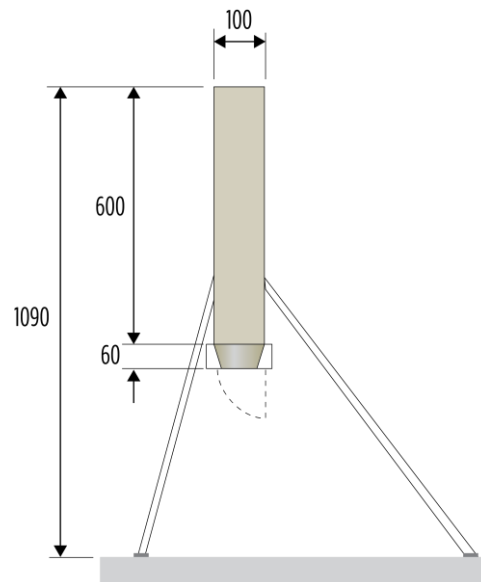

Figure 25.11 – Orimet Test Method (all dimensions are in millimetres)

3. HARDENED STATE PROPERTIES

3.1 STRENGTH

General – Concrete is a strong material in compression (i.e. it can resist quite high crushing loads) but it is relatively weak in tension (i.e. it cracks readily if stretched or bent). To improve its resistance to tensile (and shear) stresses concrete is normally reinforced with steel – as was discussed in Part I of this Guide.

Concrete has tensile strength at a level of about one-tenth of its compressive strength. Its tensile and flexural strengths are important properties of the material when it is used in pavements, slabs on the ground and similar applications. In such cases, the tensile strength of the concrete must be sufficient to resist any bending actions that are applied when the concrete member is loaded.

Because compressive strength is readily determined, and because most of the desirable

hardened-state properties of concrete improve as compressive strength increases, compressive strength is the parameter commonly used as a measure of the overall quality of concrete. In AS 1379, the grade of concrete is a primary descriptor – with characteristic strengths of the various grades ranging from 20-100 MPa.

Types and Test Methods – Compressive Strength: The compressive strength of concrete is a measure of its ability to resist loads which tend to crush it. It is assessed by measuring the maximum resistance to crushing offered by a standardised test specimen (**Figure 25.12**).

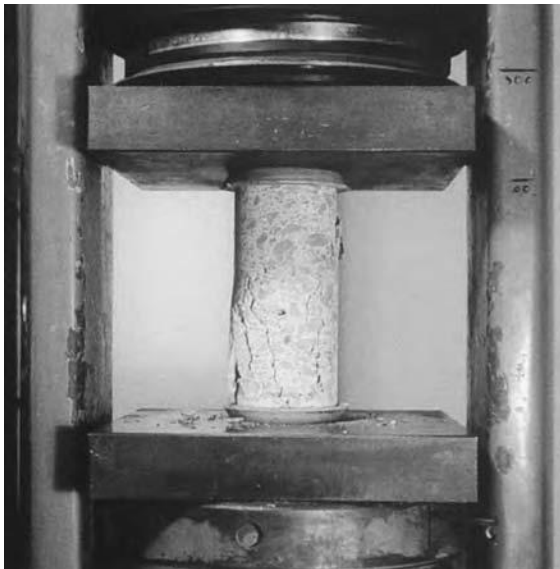

Figure 25.12 – Testing a Cylinder for Compressive Strength

In Australia, specimens used for compressive strength testing may be either 150 mm diameter x 300 mm high cylinders; or 100 mm diameter x 200 mm high cylinders – with the latter size being most commonly used. Note that the length : diameter ratio is 2 : 1.

Concrete may also be tested using a cube specimen with 150 mm sides – this being common practice in many other countries (e.g. the UK and USA).

It should be noted that different sized and shaped test specimens will give different results for a given concrete and that strength comparisons are only valid if test specimens of the same shape and dimension are used.

The compressive strength difference when using the two cylinders size options is slight and AS 1012.8.1 allows either to be used for determining compressive strength – but data from the two groups may not be combined. The 150 mm cube specimens give higher values than those obtained from cylinder specimens, and appropriate conversion factors must always be applied to allow results to be compared.

(NOTE: When evaluating compressive strength data reported from other countries, care should be taken to ensure that the size and dimensions of the test specimen are known, and suitable conversions made if required.)

When test specimens are prepared and cured in accordance with AS 1012.8.1 and crushed in accordance with AS 1012.9 it is expected that any variation in compressive strength results should reflect (almost entirely) variations in the properties of the concrete, rather than variability due to the specimen shape and size or the test procedures used. It is important to ensure that the procedures described in the Standards are followed exactly so that unwanted variations do not affect the results obtained.

Characteristic Strength: The characteristic strength for a concrete mix is the strength level above which 95% of the 28-day compressive strength results lie. The characteristic strength is determined by carrying out a statistical analysis of the 28-day test results obtained for a given mix (**Figure 25.13**).

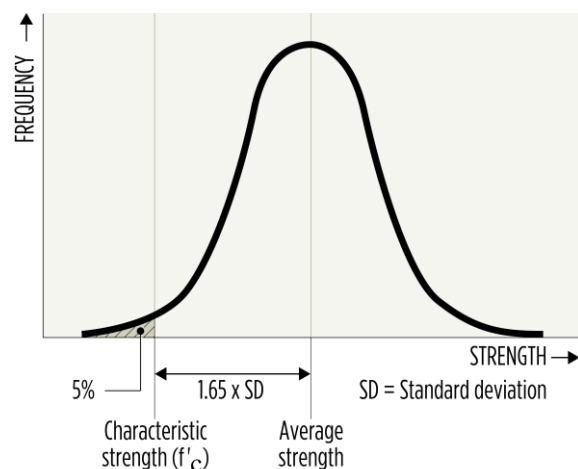

Figure 25.13 – Graphical Representation of Characteristic Strength

The 'characteristic strength' is used in the design of structures, in the ordering of concrete and in its acceptance on delivery to the construction site. It is the characteristic strength of concrete which must be specified for projects undertaken to meet the requirements of AS 3600 and is the strength on which AS 3600 bases many of its design calculations.

The 28-day characteristic compressive strengths of the standard strength grades specified in AS 1379 are 20, 25, 32, 40, 50, 65, 80 and 100 MPa.

It should be noted that the characteristic strength is determined from samples which have undergone laboratory curing and testing and effectively gives a 'potential' strength of the concrete. It does not imply that this is the strength which is actually achieved in the structure. The strength achieved in a structure is dependent, amongst other things, on the level of compaction achieved and the curing given to the concrete after it has been placed in position.

Tensile Strength: The tensile strength of concrete is a measure of its ability to resist forces which stretch or bend it. As has been noted previously, concrete is relatively weak in tension. Nevertheless, it is an important property in many applications.

There are three methods of assessing the tensile strength of concrete. These involve the application of either direct or indirect tensile forces on a test specimen.

The testing of specimens in pure tension is very difficult and it is usual nowadays to determine the tensile strength of concrete by indirect means – either by 'splitting' a cylindrical specimen along its axis or by testing a rectangular beam specimen in flexure.

Indirect Tensile Strength: The determination of the indirect tensile strength of concrete, sometimes known as the Brazil or splitting test, is described in AS 1012.10. It involves (a) making a 150 mm x 300 mm test cylinder, and (b) after curing, placing the cylinder in a rig between the platens of a compression testing machine. Load is then applied across a diameter through two bearing strips until the

specimen splits down its length (Figure 25.14).

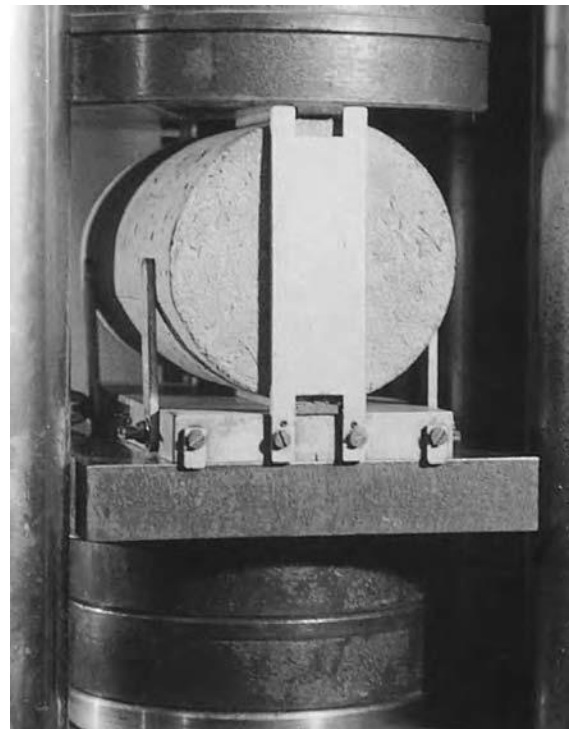

Figure 25.14 – The Indirect Tensile / Brazil / Splitting Test

The indirect tensile strength of the specimen may then be calculated using the equation provided in AS 1012.10, viz:

$$f_{ct} = 2000P/\pi LD \quad \dots \text{Eq.25.1}$$

where:

- f_{ct} = indirect tensile strength (MPa);
- P = maximum applied force indicated by the testing machine (kN);
- L = cylinder length (mm);
- D = cylinder diameter (mm).

Flexural Strength: The flexural strength of concrete, a measure of its ability to resist bending, may be determined by the method described in AS 1012.11. A plain beam of concrete is prepared using the methods described in AS 1012.8. It may be either 150 mm x 150 mm in cross-section by 500 mm in length; or 100 mm x 100 mm by 350 mm in length. After appropriate curing and (if necessary) conditioning to ensure that its surfaces are saturated, the specimen is subjected to bending, using loading at the

one-third points on the top of the beam until it fails (**Figure 25.15**).

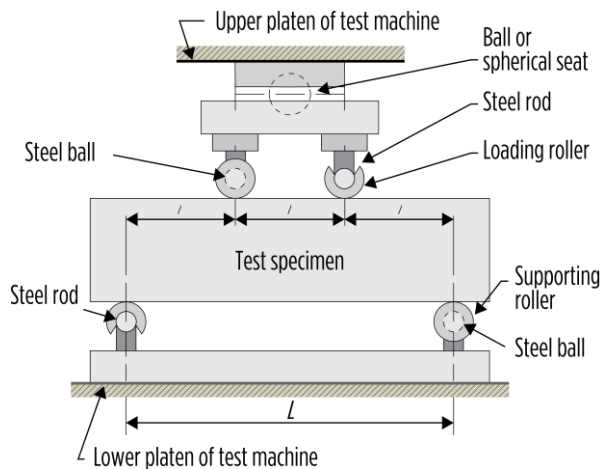

Figure 25.15 – Flexural Strength Test

The flexural strength of the specimen, or more properly, its modulus of rupture, is then calculated using the equation given in AS 1012.11, viz:

$$f_{cf} = PL(1000)/BD^2 \quad \dots\dots \text{Eq.25.2}$$

where:

- f_{cf} = modulus of rupture (MPa);
- P = maximum applied force indicated by the testing machine (kN);
- L = span length (mm);
- B = average width of the specimen at the section of failure (mm);
- D = average depth of specimen at the section of failure (mm).

For a given concrete, the flexural strength test gives a considerably higher value of tensile strength than the splitting test, and there is not a direct relationship between them. In AS 3600, the characteristic flexural strength can be calculated as $0.6\sqrt{f_c}$ and this value is used for design purposes.

(NOTE: f_c is the characteristic compressive strength.)

There is also no fixed relationship between average compressive and average tensile strength. This relationship has been widely investigated and a number of authorities have proposed bands within which such a relationship might be expected to fall. One example of the relationship is illustrated in **Figure 25.16**. It can

be seen that there is a different relationship for compressive strength versus either flexural strength or indirect tensile strength. All strength properties are affected by the water/cement ratio of the mix and by the level of compaction and nature of curing. It has also been found that (a) the tensile strength of concrete increases more slowly than its compressive strength, (b) air content has a greater effect on compressive strength, (c) the size, shape and surface texture of coarse aggregates has a greater effect on tensile strength, and (d) the variability (Standard Deviation) of tensile strength testing is about twice that of compressive strength testing.

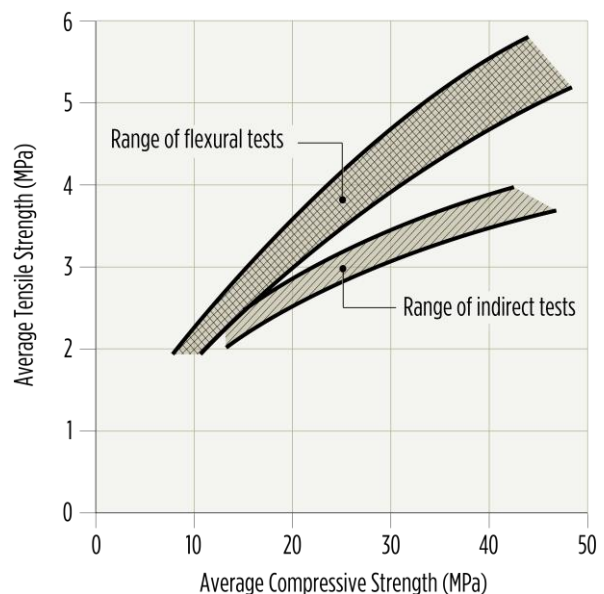

Figure 25.16 – Relationships between Compressive and Tensile Strength^{25.2}

The design of concrete pavements is typically based on the flexural strength of concrete. From a practical perspective, given the relative simplicity of compressive strength testing, it is usual practice to determine the relationship between the flexural strength and compressive strength for the particular concrete mix being used and to control the quality of the concrete produced for the project by controlling its compressive strength. The higher precision of compressive strength testing is also of assistance in these situations.

Factors Influencing Strength – Water/cement Ratio: The water/cement ratio of a concrete mix is one of the most important influences on concrete strength since it is one of the factors

which governs the porosity of the cement paste and, consequently, its strength. W/C ratio is calculated by dividing the mass of 'free' water in the concrete mix by the mass of cementitious material. Thus:

$$\text{Water/cement ratio (W/C)} = \frac{\text{mass of free water}}{\text{mass of cementitious material}}$$

[NOTES: (1) Where cement only is used, the W/C ratio calculation uses only the mass of cement. Where SCM's are also used, the W/C ratio calculation uses the sum of the masses of cement + SCM(s). (2) 'Free water' is water which is available to combine chemically with the cement and to increase workability and excludes the water which is absorbed into the aggregates.]

The influence of the water/cement ratio on the strength of concrete is illustrated in **Figure 25.17**. As can be seen, compressive strength increases as the W/C ratio decreases.

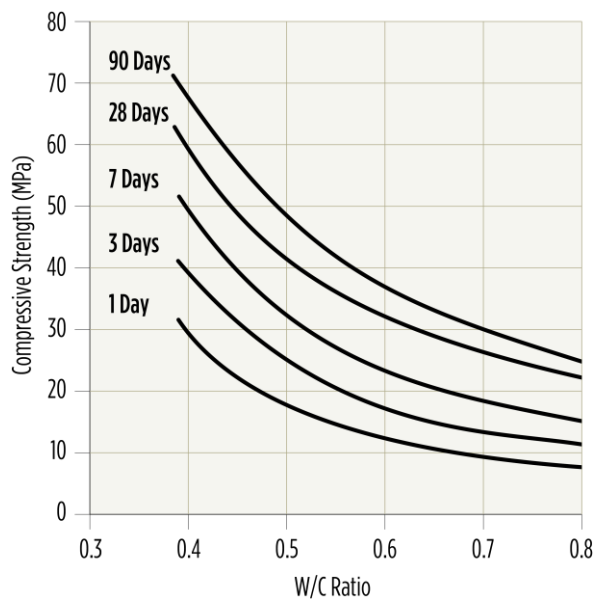

Figure 25.17 – The Influence of W/C on Compressive Strength at Various Ages

In calculating and in controlling this ratio, it is important to be aware of the 'free water' which is normally present in the aggregates, particularly in the sands. This can be a very significant amount in the context of the whole mix. Conversely, it is important to realise that dry aggregates can absorb water. In both cases, appropriate adjustments should be made to the calculation of the amount of 'free water' available in the mix.

Standard compaction and standard (i.e. extended moist) curing are essential for the relationship to be definitive. Normally, water/cement ratio curves are produced for concretes that have been cured for 28 days but can be produced at all ages.

Similar curves can be produced for different types of cement and aggregates, for different curing regimes and for different ages. They are extremely useful in predicting the potential strength of a concrete (when the free water and cement content of the mix are known) and are essential in any mix-design process.

Extent of Voids: The presence of voids in concrete can occur in several ways. Poorly compacted concrete has void spaces due to the presence of entrapped air (air not removed during compaction), and voids are also present due to intentionally entrained air when AEA's are used in the concrete mix. At the micro-scale, high levels of capillary porosity are present in mixes with high W/C ratios.

For a given concrete mix, the maximum potential strength will be achieved only with full compaction – i.e. if all voids or spaces between the particles of aggregate are filled with cement paste and all entrapped air is expelled from the concrete during placing. The influence of voids on the compressive strength of concrete can be seen in **Figure 25.18**.

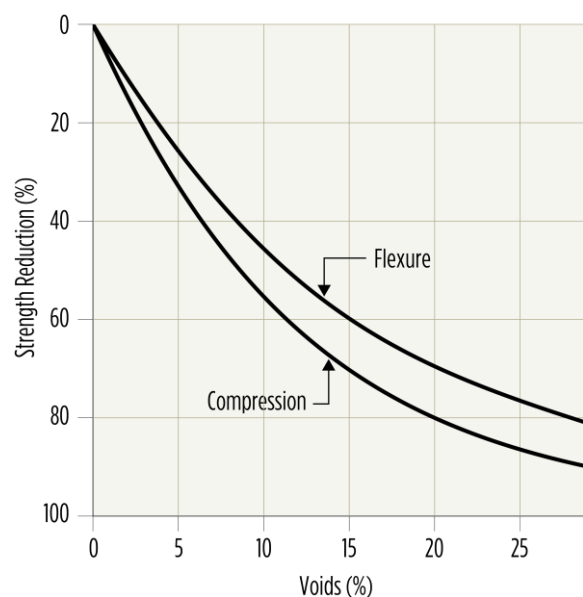

Figure 25.18 – The Effect of Air Voids on Compressive and Flexural Strengths of Concrete

Degree of Hydration: Because the reaction between cement and water is time-dependent, it is essential that moisture is present for a sufficient time to allow the reaction to proceed and for full strength to develop. The effect on compressive strength when different curing regimes are used can be seen in **Figure 25.19**. The substantial reduction in potential strength which results from inadequate curing is obvious. In the case of ‘air curing’, there is total reliance on the water included initially in the mix and which has not been evaporated from the surface of the concrete, for ongoing hydration and strength development.

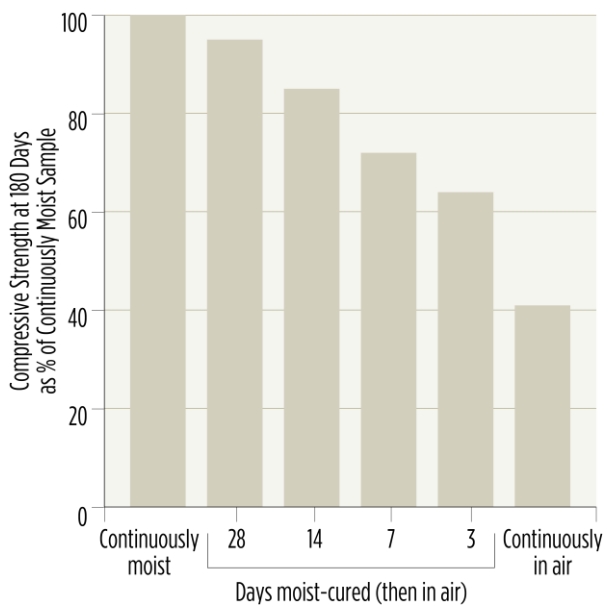

Figure 25.19 – The Influence of Moist Curing on the Strength of Concrete

The hydration reaction and consequent strength development can continue for significant periods of time. The reaction is most vigorous in the first week, but then slows progressively. Hydration and strength development may continue for long periods when water is present – particularly if SCM’s are included in the mix.

Type of Cement: The rate of strength development will depend on the type of cement used.

Figure 25.20 illustrates the effects of cement type and age on the strength of concrete. It can be seen that, in general, Type GB cements produce concretes that gain strength more slowly during the first few days relative to Type

GP cements. After 28 days the strength of mixes containing Type GB cements generally increases more substantially.

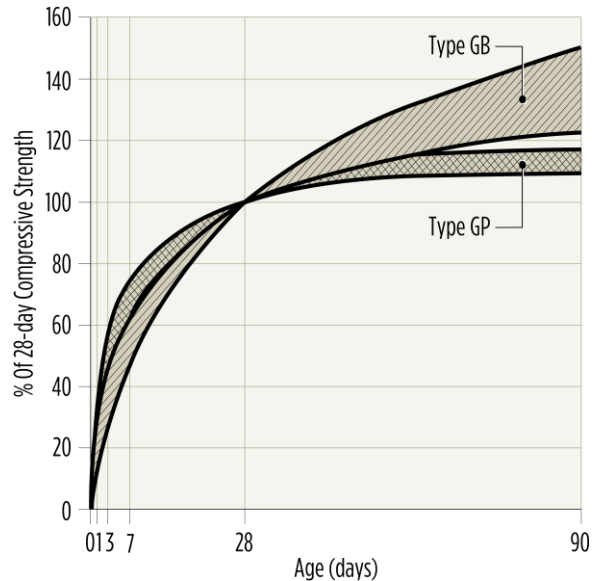

Figure 25.20 – Concrete Strength Development – Type GP and Type GB Cements

Curing Temperature: The cement hydration reaction is a chemical reaction, and like any chemical reaction the rate of reaction is influenced by temperature. Higher temperatures (either ambient temperatures or steam curing) accelerate the rate of strength gain and initial compressive strengths are higher than would otherwise be expected. It is also noted that 28-day strengths with high temperature curing are lower than when the same mix is cured at (say) 23°C. Low temperature environments lower the rate of strength gain and can be problematic when trying to place concrete in cold environments (see Part V, Section 18 of this Guide ‘Hot- and Cold-Weather Concreting’).

Other Factors: Other factors which may affect the strength of concrete, either directly or indirectly, include the quality of the aggregates, the quality of the mixing water, the type of admixture used (if any) and density. These factors are discussed more fully in other Sections of this Guide, but their effects can be summarised as follows:

Aggregate Quality: Almost any rock or stone which is sound and durable can be used to make good concrete. However, those which are

weak and friable (e.g. sandstones), or those which expand and contract when wetted and dried (e.g. those containing clays and clay minerals) should be avoided.

Particle shape and surface texture are also important, particularly where high tensile strength is being sought. Approximately cubical aggregate particles are to be preferred to flat 'slivery' particles; and a slightly rough texture, which binds well with the cement paste, is to be preferred (in general) to smooth, glassy surfaces. However, it needs to be emphasised that good concrete can be made from a wide range of rocks/stones. Whilst it is appropriate to exercise care in the selection of aggregates, specification and use of only the 'best' materials can lead to uneconomical use of what is becoming a limited resource.

Water Quality: In general terms, any water which is suitable for drinking, and which has no marked taste or odour, is suitable for use in making concrete. Water which is contaminated with organic matter, or which contains dissolved salts, may be unsuitable because the contaminant may affect the strength of the concrete or lead to corrosion of embedded reinforcement. Where any doubt exists, testing of the water in concrete should be carried out. Testing of samples from a concrete mix made with the unknown water and comparison with samples from concrete of known performance should be undertaken and any effect on compressive strength and setting time noted. AS 1379 sets limits for the allowable effects on these properties.

Admixtures and Additives: A wide range of admixtures may be used in concrete – ranging from air-entraining agents used to enhance the resistance of concrete to alternating cycles of freezing and thawing to high-range water-reducers (superplasticisers) used to make flowing concrete. Additives may include simple oxide colourants through to highly reactive pozzolanic materials like silica fume that vastly improve strength and durability performance. Almost all are likely to have some effect on concrete strength – either to reduce it or to increase it – although some admixtures are carefully formulated to have minimal effect. In all cases, the effect of an admixture or additive

should be investigated by trial mixes before being used.

Density: The Standards AS 1379 and AS 3600 generally relate to 'normal weight' concrete mixes, although AS 3600 does include reference to 'lightweight' concretes with a density range of 1,800-2,100 kg.m⁻³. If concrete density is reduced by using any of a variety of means – e.g. foaming, using light-weight aggregates or using polystyrene beads as a partial aggregate replacement – then lower compressive strengths will be achieved.

3.2 DURABILITY

General – The permeability and absorptivity of concrete are important properties that impact the durability performance of concrete. These properties of concrete directly impact watertightness and directly and indirectly they affect (a) the ability to protect steel reinforcement from corrosion, (b) the resistance to chemical attack and (c) resistance to other deteriorating influences. In addition, any internal or external agent that can result in a concrete volume change can have a significant impact on concrete durability.

These properties and the material attributes affecting them are discussed below. These properties contribute to the ability of concrete to resist various in-service conditions which are also discussed.

Permeability and Absorptivity/Sorptivity – Broadly speaking, the sorptivity of concrete is a measure of the amount of water (or other liquid) which the concrete will absorb when immersed in it – in circumstances where no head of water (or other liquid) exists. This absorption, due to capillary suction, occurs through the surface of the unsaturated concrete element. The permeability of concrete is a measure of its resistance to the passage of fluids (gases or liquids) through it under pressure. Both properties are affected by similar factors, namely (a) the porosity of the concrete (i.e. the volume of voids or pores in the concrete) and (b) whether these voids or pores are separated (discrete) or interconnected. There is no direct relationship between porosity and permeability – it is possible to have concrete which has a

high porosity, but a relatively low permeability (if the pores and voids in it are relatively large but disconnected). Similarly, it is possible to have concrete with a high absorptivity but low permeability. However, in practice, concrete with a high absorptivity will generally have high permeability.

The main material attributes affecting permeability and absorptivity are:

Water/cement Ratio: The permeability of cement paste is directly related to its water/cement ratio. High W/C ratio mixes have high levels of capillary porosity and, while up to a point this porosity can be filled by ongoing hydration reaction product, long periods of water curing are required for this to occur. To achieve reasonably low levels of permeability, the W/C ratio of a mix should be less than 0.5 (**Figure 25.21**).

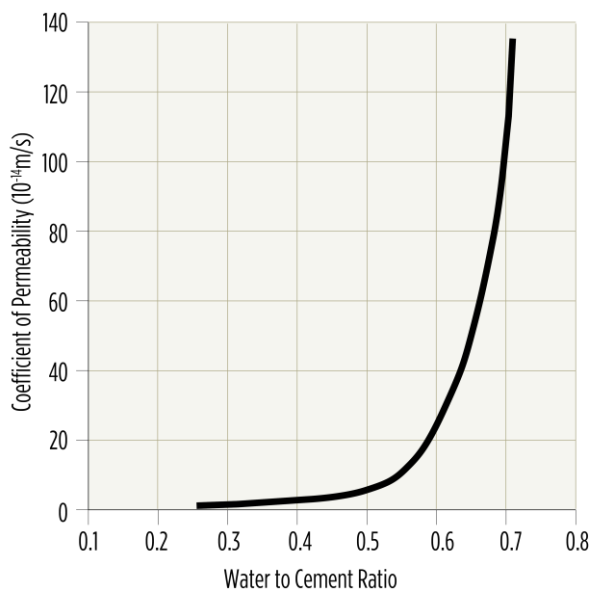

Figure 25.21 – The Effect of Water/Cement Ratio on the Permeability of Concrete^{25,3}

Extent of Voids and Capillaries: Incomplete compaction of concrete results in comparatively large (entrapped) air voids being present after it has hardened. In most cases, incomplete compaction will also result in water being trapped under aggregate particles, leaving further voids as it dries out. Incomplete compaction results, therefore, not only in lower concrete strengths but also in higher permeability.

Although low water/cement ratios are necessary to achieve low-permeability concrete, any reduction below that needed for good workability (and therefore ease of compaction) can have contrary effects. In modern concrete technology, the use of admixtures (and particularly HRWR) has allowed low W/C ratio mixes with good workability to be produced.

The hydration of cement produces products that not only bind the aggregate particles together but also reduce the size of voids and capillaries within the paste, thereby reducing its permeability. Curing the paste for a sufficient period of time is important in the production of low-permeability concrete. As can be seen in **Table 25.4**, this time is a function of the water/cement ratio of the paste, which helps to explain why limiting the water/cement ratio to a figure below 0.5 is so often recommended for the achievement of low-permeability concrete. It is difficult to practically cure concrete for a sufficient length of time to achieve capillary discontinuity at water/cement ratios greater than 0.5.

Table 25.4 – Curing Time required for Capillary Discontinuity of Cement Paste

Water/cement ratio (by mass)	Curing time required for capillary discontinuity
0.40	3 days
0.45	7 days
0.50	14 days
0.60	6 months
0.7	1 year
over 0.7	Impossible

The effectiveness of curing in practice is shown in **Figure 25.22** which illustrates how a significant reduction in water sorptivity of a nominal 25 MPa concrete is achieved in over as little as three days when cured in timber formwork.

Type of Cement: Pozzolanic materials incorporated in concrete tend to reduce its

permeability by reacting with cement hydration products to form additional cementitious products which are then deposited in the pores and capillaries, reducing their size, volume and continuity.

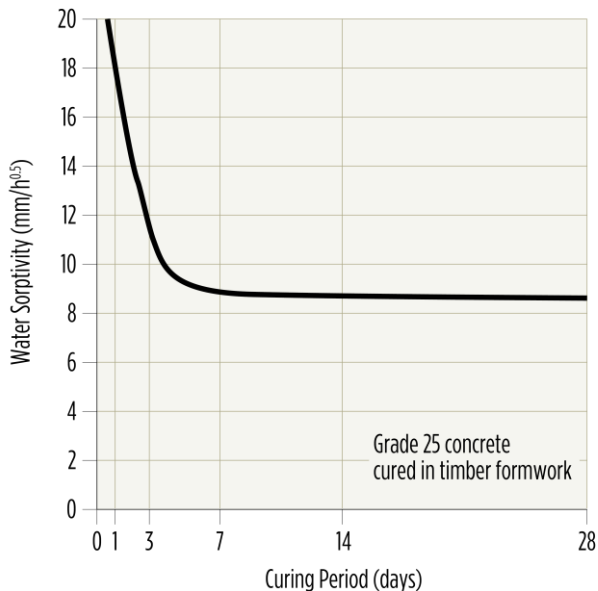

Figure 25.22 – The Effect of Curing Time on Water Sorptivity

Blended cements (e.g. Type GB cements or Type GP cement + SCM's) are often used in the production of concrete with low permeability. Curing is especially important with blended cements, as the pozzolanic reaction occurs over a much longer time period.

Admixtures and Additives: Chemical admixtures may help reduce the permeability of concrete. Water-reducing agents – by permitting a reduction in the water/cement ratio of the paste for a given workability – help reduce the permeability of the paste.

Volume Change – During its life cycle, concrete may undergo many changes to its initial volume. Initially, there is a reduction in volume (or contraction) as the concrete is compacted and air and moisture are expelled from it. Later, there is the slight expansion which takes place as the cement hydrates. Eventually there is further contraction (or shrinkage) which occurs when the hardened concrete dries out through evaporation of moisture from its surface.

Subsequent cycles of wetting and drying will cause it to expand and contract as it gains and

loses moisture. Indeed, these cycles continue throughout the life of the concrete as it gains and loses moisture with changes in the relative humidity of the atmosphere (**Figure 25.23**).

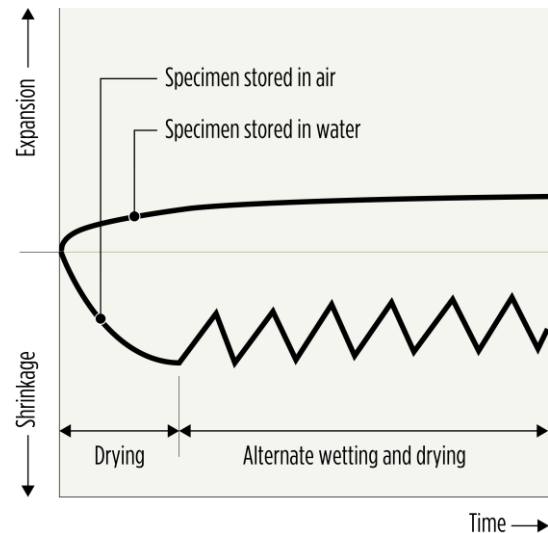

Figure 25.23 – Diagrammatic Illustration of Moisture Movement in Concrete

In addition, there is movement which occurs when concrete is heated and cooled (i.e. thermal expansion and contraction).

If concrete was free to move without restraint these changes would be of little concern. However, this is rarely the case as most concrete elements are normally restrained in one way or another (e.g. by friction between a slab and the ground or by adjoining/attached elements).

Volume changes under restraint conditions can create significant stresses – particularly tensile stresses. It is important, therefore, to minimise these changes to prevent cracking. In some cases, it may also be important to reinforce the concrete to help resist these stresses.

For convenience, it is normal to measure movements in concrete as a change in length per unit length, rather than as a change in volume. Movements may be expressed as a coefficient in (a) parts per million, (b) as a percentage change in length or (c) as a movement in millimetres per metre. In concrete technology, movement is typically reported using the term *microstrain* which is *parts per million* (e.g. a change in length described as

being 850 microstrain is 850 parts per million, which is equivalent to a change in length of 0.085% or 0.85 mm/m).

Drying Shrinkage: Volume change due to drying shrinkage is an important property as excessive drying shrinkage can lead to cracking that is detrimental to performance, durability and/or appearance (e.g. in pavements, cracking must be strictly controlled to ensure the integrity of the pavement as well as limit ingress of materials that might cause corrosion of reinforcement).

Figure 25.24 illustrates the drying shrinkage that occurs when concrete dries out over a period of three months. Concrete drying shrinkage is measured on beams in a laboratory test environment and results are reported after 56-day drying at a temperature of 23°C and at 50% RH. Specifications are generally written on the basis of drying shrinkage values determined using this test, however the laboratory results are generally much higher than those found in concrete exposed in the field. Drying shrinkage will continue for years, but when considered after 20 years, it is found that about 65% of the total (20-year) drying shrinkage occurs in about 3 months and 75% in the first year.

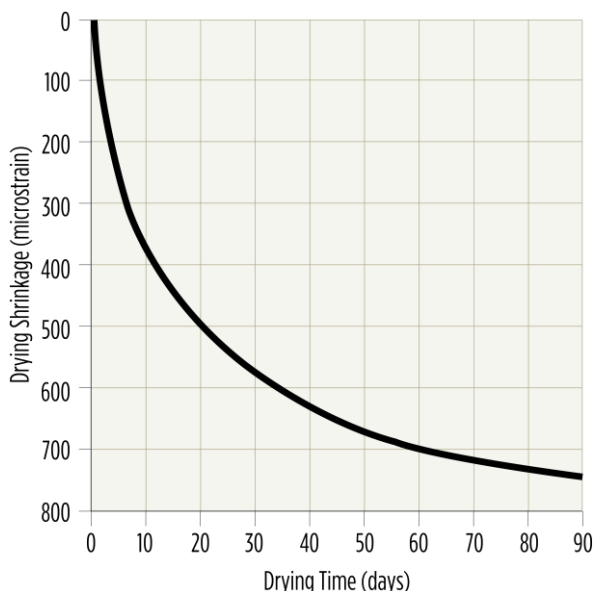

Figure 25.24 – Drying Shrinkage vs. Time Curve for a Typical Concrete Specimen

Research has shown that the major factor influencing levels of drying shrinkage is the total

amount of water in the concrete. This should be kept to the minimum amount necessary to achieve adequate workability.

Other factors which can affect drying shrinkage include:

Proportion and Nature of Aggregates: The higher the volume proportion of aggregates in a mix, the lower will be the drying shrinkage because (1) the aggregates tend to restrain drying shrinkage, and (2) more aggregates means less cement paste – and it is the paste that shrinks. Aggregates which themselves exhibit significant moisture movement characteristics will adversely affect drying shrinkage performance.

Contamination of Aggregates: Aggregates contaminated with clay or very fine material increase the water demand of the concrete which may lead to increased drying shrinkage.

Maximum Aggregate Size: Larger-sized aggregates tend to reduce drying shrinkage through being more effective in restraining shrinkage.

Cement Content: High cement contents mean higher paste contents which leads to higher levels of drying shrinkage. Almost invariably, water loss contributing to drying shrinkage comes from the paste and not from the aggregates.

Creep – Creep is a form of concrete deformation that occurs over long periods of time – namely years. Examples of the effects of concrete creep include the shortening of building columns, deflection of floors or beams and loss of strength in prestressed concrete. While it can be detrimental, concrete may be too brittle if there was no creep. Some creep is desirable.

Figure 25.25 shows how creep increases slowly after load is applied to a concrete element, and then decreases to an extent when the load is removed. However, the element does not recover to its initial state as a proportion of the creep is 'residual'. Creep can be related to the stiffness and permeability of concrete, and consequently the factors that affect these properties also affect creep. The concrete strength and modulus of elasticity at

the time of loading also affect the amount of creep deformation as do the applied load and conditions such as moisture content and RH.

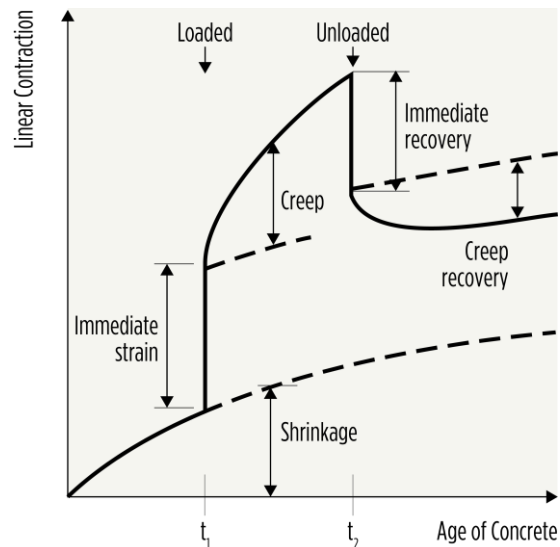

Figure 25.25 – Creep Deformation of Concrete

Thermal Movement – Concrete moves with changes in temperature – expanding when heated and contracting when cooled. While the amount of movement is not great (ranging from 5-12 microstrain per °C) stresses induced by thermal expansion can be significant. As a result, it is normal practice to introduce control joints into concrete structures at appropriate intervals.

The type of aggregate used in the concrete is the major factor influencing thermal expansion (**Table 25.5**).

Table 25.5 – Coefficients of Expansion resulting from Use of Different Aggregate Types

Aggregate type	Coefficient of expansion of resulting concrete (microstrain/°C)
Quartz	11.9
Sandstone	11.7
Gravel	10.8
Granite	9.5
Basalt	8.6
Limestone	6.8

In-Service Durability Properties – Resistance of Reinforcement to Corrosion: Perhaps the most common (and obvious) form of deterioration in concrete is that caused by the corrosion of reinforcement. This is normally accompanied by cracking and spalling and ultimately, by disintegration of the member. Under normal circumstances concrete protects steel embedded in it in two ways. It encloses the steel in an alkaline environment (with a pH >12) that 'passivates' the steel (by allowing the formation of a thin, resistant iron oxide film on the surface of the steel) and prevents it from corroding. It also minimises the movement of moisture and oxygen through the concrete – both of which are necessary for corrosion to occur.

This passivation protection can be breached in two ways, viz:

Carbonation: Carbon dioxide from the atmosphere reacts with the lime that creates the high concrete paste pH. The result is that concrete pH is reduced, with the consequence being that the steel can be 'depassivated' and corrosion initiated.

Chloride Ion Penetration into the Concrete: Chloride ions can destabilise the passivating oxide layer on the reinforcement even though the alkalinity may not have been reduced. Chloride ions may be present in the concrete materials and slowly act on the steel. Chloride ions may also be introduced to the concrete by exposure to sea water or from other salt-containing environments and these chloride ions can then slowly diffuse through the concrete until they reach the steel. To minimise the likelihood of chloride containing materials being incorporated in concrete, Standards (for cement, SCM's and admixtures) now contain strict chloride limits.

The effects of both carbonation and chloride ion diffusion can be managed by the use of low-permeability concrete [i.e. concrete with a low water/cement ratio and generally containing SCM(s)]. The benefits of using SCM's are shown in **Figure 25.26** and **Figure 25.27**. In addition, concrete with low volume-change characteristics (i.e. concrete that is less susceptible to cracking) is also beneficial. As well as using high quality concrete, adequate

concrete cover is necessary to protect the reinforcing steel, with guidance in relation to cover depths being provided in AS 3600 in the form of a table that defines the minimum requirements for cover depth which are dependent on the local exposure classification (see **Figure 25.32**) and the grade of concrete being used (**Table 25.6**).

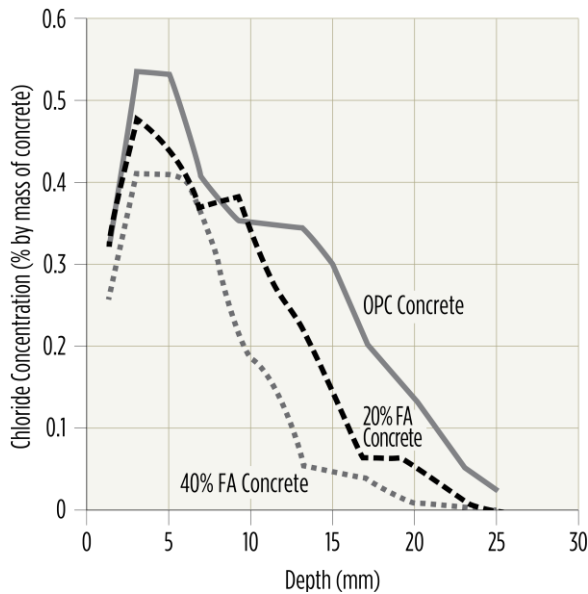

Figure 25.26 – Chloride Ingress reduced by Fly Ash

Resistance to Chemical Attack – Concrete, or, more specifically, the cement paste in concrete, is susceptible to attack by a variety of common chemical species.

In some circumstances, the chemical agent converts the constituents of the cement paste

into a soluble salt, which can then be dissolved and removed by water.

The intensity of the attack will depend on:

- The nature of the chemical and its concentration;
- Ambient conditions; and
- The type of exposure (e.g. Intermittent or continuous; in a static or flowing environment).

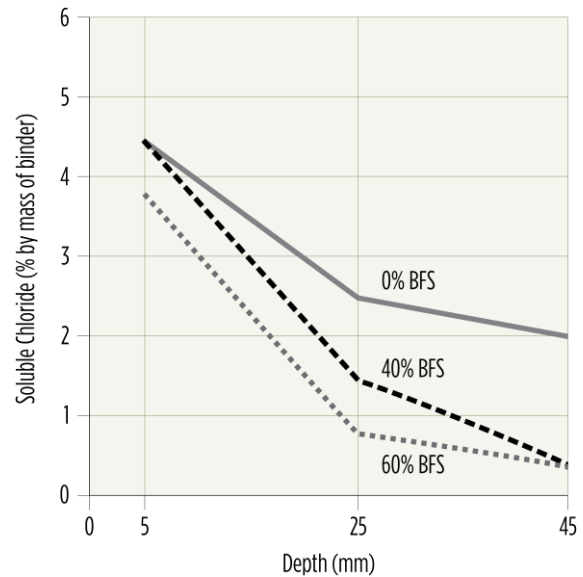

Figure 25.27 – Chloride Ingress reduced by GGBFS

Table 25.6 – Concrete Cover Requirements – AS 3600^{25.4}

Exposure classification	Required cover (mm)				
	Characteristic strength f_c (MPa)				
	20 MPa	25 MPa	32 MPa	40 MPa	≥50 MPa
A1	20	20	20	20	20
A2	(50)	30	25	20	20
B1		(60)	40	30	25
B2			(65)	45	35
C1				(70)	50
C2					65

Notwithstanding these factors, the rate of attack by any particular chemical agent is determined significantly by the permeability of the cement paste. Without exception, low water/cement ratio pastes with corresponding low permeabilities will perform better than those with higher permeabilities as reactions may be able to be confined to the surface of the concrete.

The effects from a number of common materials are discussed below.

Acids: Most acidic (low pH) materials will attack the (high pH) cement paste by converting the lime and CSH into readily soluble salts. (e.g. hydrochloric acid, which is commonly used to etch or to clean cement-based product surfaces, forms chloride salts which are readily soluble in water.)

Similar effects occur with other strong acids including sulfuric and nitric acids. Oxalic, tartaric, and hydrofluoric acids are unusual in that the products of their reactions with cement are almost insoluble. They are sometimes used, therefore, to provide a measure of chemical resistance or 'hardening' to concrete surfaces. Their application produces a layer of insoluble reaction product which helps to protect the surface from further attack.

Naturally occurring waters (e.g. ice melt) are sometimes acidic due to dissolved carbon dioxide, but attack in such cases is usually slight. Where such water is flowing at high velocity there can be significant deterioration of the concrete over time.

Soft Waters: Very pure (or soft) water can attack concrete by leaching out calcium-bearing compounds from the cement paste (e.g. calcium hydroxide) leaving behind material with reduced strength. Such attack can occur in areas of high rainfall or with melting snow. Again, a dense low-permeability concrete will help resist this form of attack. The use of pozzolanic materials, to help reduce permeability and to reduce the free calcium hydroxide in the hydrated paste, is also of value.

Sulfates: Solutions containing soluble sulfates can attack concrete vigorously. In some cases, the reactions result in the formation of reaction

products with higher volumes than the original material which causes an expansion of the paste and cracking and (potentially) disintegration of the concrete.

Sulfates are found in industrial effluents, in sewerage and in some soils and groundwaters. Sodium sulfate reacts with lime to form expansive calcium sulfate, resulting in concrete cracking.

The resistance of concrete to sulfate attack can be improved by the use of dense, low-permeability concrete (**Figure 25.28** and **Figure 25.29**) which restricts ingress of the sulfate solutions to the interior of the element. It may also be improved by the use of sulfate-resisting (Type SR) cements and SCM's in the concrete mix (**Figure 25.30** and **Figure 25.31**).

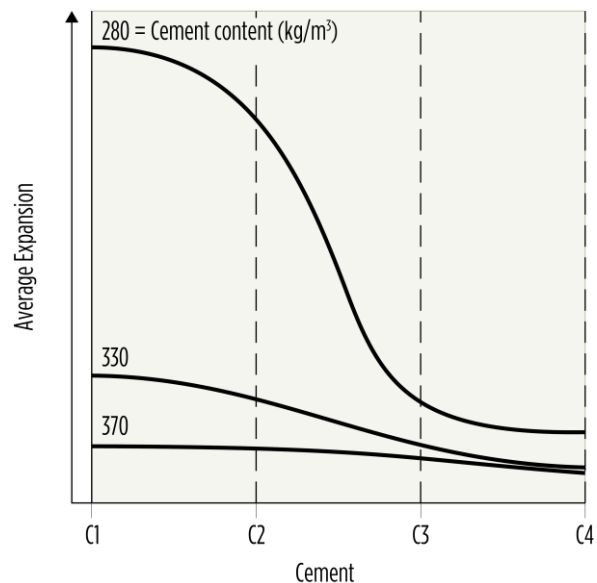

Figure 25.28 – Cement Content and Sulfate Attack

Seawater: Seawater contains about 3.5% of dissolved salts, primarily sodium and magnesium chloride, as well as dissolved sulfates (e.g. magnesium, calcium and potassium sulfates).

The chlorides in seawater do not attack concrete directly but exposure can lead to corrosion of any reinforcing steel embedded in the concrete. The sulfates in sea water, and particularly magnesium sulfate, will cause damage to immersed concrete elements, and more-so if the water flows at a reasonable velocity. Magnesium sulfate will actually attack the CSH and cause the body of the concrete to

disintegrate. In general, as well as using concrete with low permeability, 'Marine Cement' (typically a cement containing Type GP + 65% GGBFS) is used for concrete intended for this type of environment.

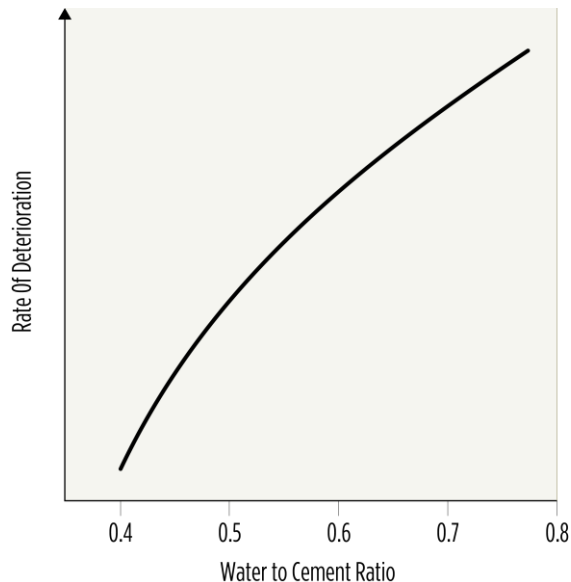

Figure 25.29 – W/C Ratio and Sulfate Attack

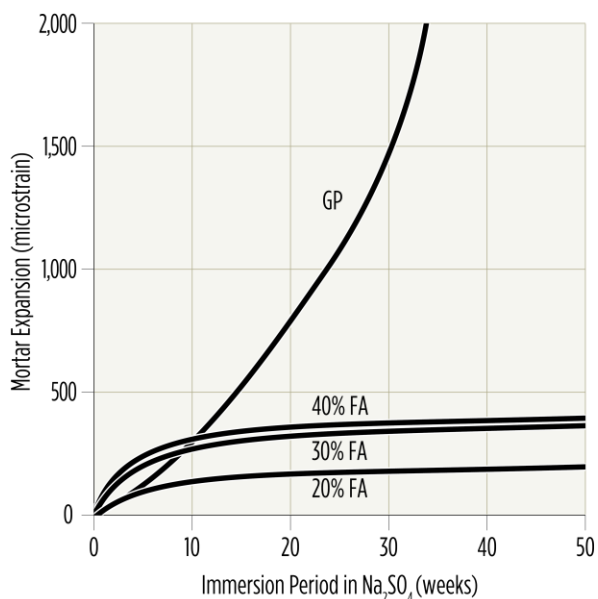

Figure 25.30 – Fly Ash Use and Sulfate Attack

Concrete partially immersed in seawater which undergoes wetting and drying cycles (e.g. in the inter-tidal zone) can be damaged by the crystallisation of salts inside the concrete surface in zones subject to the continual wetting and drying. The permeability of the concrete is a critical factor if damage is to be avoided in these situations. The more permeable the

concrete, the more rapid will be the deterioration.

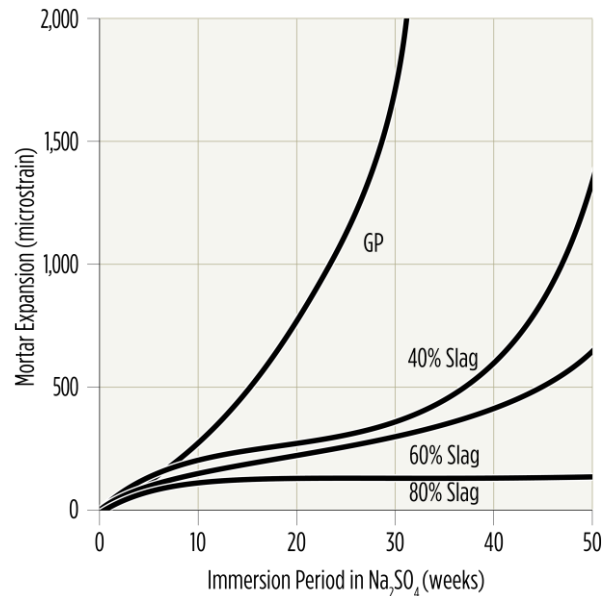

Figure 25.31 – GGBFS Use and Sulfate Attack

Abrasion Resistance – In many applications, such as industrial floors, concrete surfaces are subjected to wear or some form of attrition from things such as vehicular traffic, sliding/scraping objects or repeated blows. In hydraulic structures, wear can also be caused by the action of abrasive material in water or by cavitation.

Foot traffic can be one of the most damaging sources of abrasion, and areas where a concentration of pedestrians occur (e.g. shopping malls) are subject to very high levels of wear.

Because the actual abrasion which occurs in a given situation depends so much on the exact cause, it is impossible to be precise regarding the characteristics required of concrete to resist wear. However, tests have shown that, in general, the higher the compressive strength, the better is the wear resistance of concrete. With lower concrete compressive strength, the wear-resistance properties of the aggregates become important as they will eventually need to provide the wearing surface.

Guidance regarding the required grade of concrete for various wear situations is provided in AS 3600 and shown in **Table 25.7**.

Proprietary topping and shake mixtures are commonly added to the surface of floors to increase improved wear resistance. In effect, these materials provide a thin, high-strength layer which may also incorporate very hard-wearing aggregates. Steel fibres are also sometimes added to increase resistance to abrasion in industrial situations.

Freeze-Thaw Resistance – As the temperature of saturated concrete is lowered below freezing point, the water held in the capillary pores freezes and expands. The force which the expanding ice exerts may then exceed the tensile strength of the concrete and cause the surface layer to scale or flake off. Repeated cycles of freezing and thawing cause

successive cycles of scaling and, ultimately, complete disintegration of the surface of the concrete.

To increase the freeze-thaw resistance of concrete it is normal practice to incorporate entrained air in the mix (i.e. create discrete, evenly distributed microscopic air bubbles in the cement paste). These small voids relieve the hydraulic pressure which is built up during the freezing process by providing space into which the frozen water can expand to help prevent the surface-scaling which would otherwise occur. AS 3600 provides guidance as to the levels of air entrainment required (**Table 25.8**).

Table 25.7 – AS 3600 Recommended Concrete Strengths for Abrasion Resistance^{25.5}

Member and type of traffic	Characteristic compressive strength (MPa)
Footpaths and residential driveways	20
Commercial and industrial floors not subject to vehicular traffic	25
Pavements or floors subject to:	
• Pneumatic tyred traffic	32
• Non-pneumatic-tyred traffic	40
• Steel-wheeled traffic	To be assessed – not <40

Table 25.8 – AS 3600 Requirements for Freeze-thaw Resistance

Exposure condition	Min f'_c (MPa)	Entrained air for nominal aggregate size	
		10-20 mm	40 mm
<25 cycles per annum	32	8%-4%	6%-3%
>25 cycles per annum	40	8%-4%	6%-3%

Table 25.9 – AS 3600 Strength and Curing Requirements for Durability^{25.6}

Exposure classification	Minimum f'_c (MPa)	Minimum initial curing	Minimum average compressive strength at stripping (MPa)
A1	20	3 days continuous	15
A2	25		
B1	32	7 days continuous	20
B2	40		25
C1	50		32
C2	50		

It is also normal practice to reduce the W/C ratio and to extend curing times, thereby reducing the number and volume of capillaries and pores in which water may be retained. Reducing the water/cement ratio also increases the tensile strength of the concrete, allowing it to better resist scaling and surface disintegration.

AS 3600 Durability Provisions – AS 3600 provides its durability provisions in Section 4 of the Standard. These procedures require that (1) the exposure classification be determined, (2)

the minimum concrete quality required to meet that exposure classification be determined, and (3) the minimum concrete cover to the reinforcement be chosen from tables for the exposure condition, the concrete location, the level of compaction and the concrete strength.

Guidance is provided on climatic zones as they affect durability exposure conditions – as shown in the zones A1 (Arid) – B2 (Coastal) on the map of Australia (**Figure 25.32**) [2].

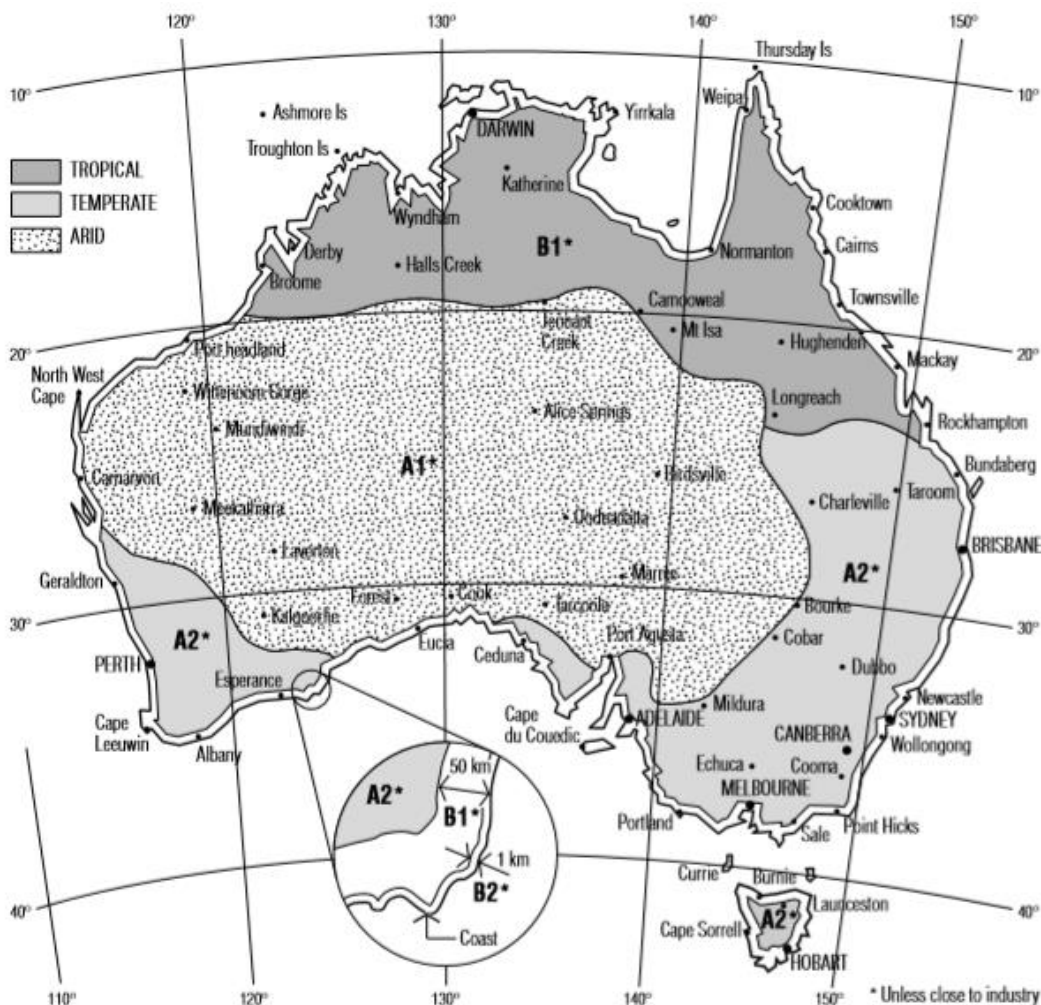

Figure 25.32 – Australian Climatic Zones^{25.7}[2]

In a marine environment (Zones C1 and C2 – Sea Water exposure), the worst conditions for the corrosion of steel are those in the tidal zone or atmospheric zone as shown in **Figure 25.33**.

In the submerged zone in **Figure 25.33**, there are unlikely to be serious corrosion conditions, but the concrete could still be subject to attack from sulfates in the seawater. In the tidal zone

there are a number of factors likely to create issues including attack from sulfates, chloride ion ingress and physical abrasion from the movement of water and suspended materials. The atmospheric zone also has some potentially serious issues including ongoing wetting and drying cycles with sea water containing soluble salts.

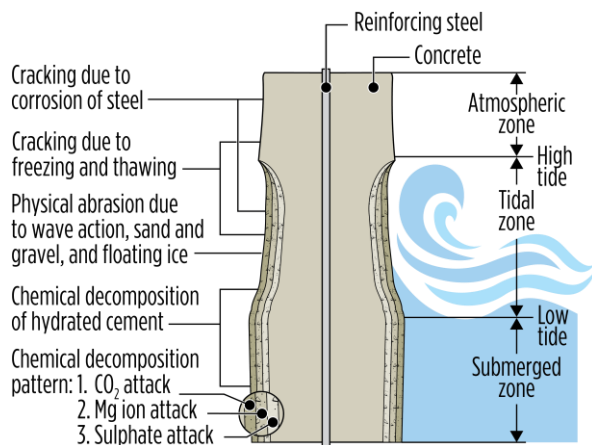

Figure 25.33 – Marine Exposure Conditions

Local environmental factors need to be taken into account when determining the minimum characteristic strength to be used and the curing time required to accommodate the relevant environmental issues. These are shown in **Table 25.9** (from AS 3600).

A series of documents on concrete durability has been prepared by the Concrete Institute of Australia [2-5]. These documents cover a wide range of important aspects related to the understanding of concrete durability, designing durable structures and carrying out durability-related testing of concrete and concrete structures.

4. RELEVANT AUSTRALIAN STANDARDS

- 1) AS 1012 – *Methods of testing concrete*
- 2) AS 1012.1 – *Sampling of fresh concrete*
- 3) AS 1012.2 – *Method for the preparation of concrete mixes in the laboratory*
- 4) AS 1012.3 (Parts 1-5) – *Methods for the determination of properties related to the consistence of concrete*
- 5) AS 1012.8 (Parts 1&2) – *Method for making and curing concrete compression, indirect tensile and flexure test specimens, in the laboratory or in the field*
- 6) AS 1012.9 – *Methods of testing concrete Compressive strength tests – Concrete, mortar and grout specimens*

- 7) AS 1012.10 – *Method for the determination of indirect tensile strength of concrete cylinders (Brazil or splitting test)*
- 8) AS 1012.11 – *Method for the determination of the flexural strength of concrete specimens*
- 9) AS 1379 – *Specification and supply of concrete*
- 10) AS 3600 – *Concrete structures*

5. OTHER REFERENCES

- 1) Neville, A.M. *'Properties of Concrete'* (4th Edition), Longman Group Limited, ISBN 0-582-23070-5 (1995), p. 185
- 2) Concrete Institute of Australia, *'Durable Concrete Structures'*, Recommended Practice Z-07, ISBN 0 909375 55 0 (February 2001)
- 3) Concrete Institute of Australia, *'Durability Planning'*, Recommended Practice Z-07-01, ISBN 978 0 9941738 0 5 (2014)
- 4) Concrete Institute of Australia, *'Durable Exposure Classifications'*, Recommended Practice Z-07-02, ISBN 978 0 909375 01 0, (September 2018)
- 5) Concrete Institute of Australia, *'Performance Tests to Assess Concrete Durability'*, Recommended Practice Z-07-07, ISBN 978 0 9941738 2 9 (2015)
- 6) ASTM C1611/1611M-18 – *Standard Test Method for Slump Flow of Self Consolidating Concrete*, ASTM International, West Conshohocken, PA (2018), www.astm.org

End Notes:

- 25.1 Based on Table 5.1 in AS 1379
'Specification and Supply of Concrete'
- 25.2 Based on Figure C6.1. in AS 3600
'Concrete Structures', Supplement 1 –
Commentary (2009)
- 25.3 Based on Figure 6 in Journal ACI 51
(November 1954)
- 25.4 Based on Table 4. 10.3.2 in AS 3600
'Concrete Structures' (2018)
- 25.5 Based on Table 4.6 in AS 3600 *'Concrete
Structures'* (2018)
- 25.6 Based on Table 4.4 in AS 3600 *'Concrete
Structures'* (2018)
- 25.7 After Figure A.1 (page 45) of *'Durable
Concrete Structures'*, reference [2], used with
permission of the Concrete Institute of
Australia

CONTENTS

1. OUTLINE	2	6 QUALITY CONTROL OF TESTING OTHER THAN COMPRESSIVE STRENGTH.....	16
2. SAMPLING OF CONCRETE.....	3	6.1 GENERAL.....	16
2.1 GENERAL.....	3	7. REFERENCES	19
3 TESTS ON FRESH CONCRETE	3		
3.1 GENERAL.....	3		
3.2 THE SLUMP TEST.....	4		
3.3 THE COMPACTING FACTOR TEST.....	4		
3.4 THE VEBE TEST	5		
3.5 AIR CONTENT OF PLASTIC CONCRETE.....	5		
3.6 MASS PER UNIT VOLUME OF CONCRETE.....	6		
3.7 BLEEDING OF CONCRETE	6		
3.8 SETTING TIME OF CONCRETE.....	7		
4 TESTS ON HARDENED CONCRETE	7		
4.1 GENERAL.....	7		
4.2 TEST SPECIMENS.....	7		
4.3 COMPRESSIVE STRENGTH TESTING	7		
4.4 INDIRECT TENSILE STRENGTH TESTING	8		
4.5 FLEXURAL TENSILE STRENGTH TESTING	9		
4.6 DRYING SHRINKAGE TESTING	9		
4.7 CREEP TESTING	10		
4.8 OTHER HARDENED CONCRETE TESTS.....	10		
5 QUALITY ASSURANCE OF CONCRETE	11		
5.1 GENERAL.....	11		
5.2 CONCRETE QUALITY CONTROL..	11		
5.3 STATISTICAL CONTROL MEASURES.....	12		
5.4 PRODUCTION ASSESSMENT OF CONCRETE.....	14		
5.5 PROJECT ASSESSMENT OF CONCRETE.....	15		
5.6 CONCRETE SUPPLIER MIX STRENGTH CONTROL	15		

1. OUTLINE

Tests are carried out on concrete, either in the laboratory or in the field, to determine its properties. This information may then be used in a number of ways: to determine whether the concrete complies with the requirements of a specification; to forecast how it will perform in service; to determine the effect of different materials; or simply to determine whether some change is necessary in the mix proportions, e.g. the water content.

Unless these tests are conducted strictly according to standardised procedures, the results will be of little value because they will not be comparable with results generated within a given laboratory at a different time or between different laboratories.

Whatever the purpose of the testing, it is imperative that concrete testing be conducted in accordance with standard or otherwise agreed procedures so that there can be confidence that the material meets the specified requirements, and that the results are not affected by (a) variable testing equipment performance, (b) variable testing procedures, (c) capability of testers and/or (d) chance or random factors which would make results meaningless.

This section describes the common methods used to sample and test concrete, highlighting the principal precautions which should be taken to ensure comparable (i.e. repeatable) results. It also describes the more common tests used to determine the properties of concrete and highlights the more important precautions which need to be taken in carrying them out. Full details of the various test methods are to be found in the relevant Australian Standards listed in the references to this section.

2. SAMPLING OF CONCRETE

2.1 GENERAL

It is essential that the test results (whatever use is to be made of them) are representative of the concrete being tested. Hence, it is essential that the test sample be representative of the concrete from which it is taken. AS 1012.1 sets out procedures for obtaining representative samples from freshly mixed concrete for either consistency (slump) tests or the moulding of specimens for other tests.

AS 1379 also imposes a number of requirements on the sampling of concrete. Where the sample is being taken to check the quality of the concrete being supplied to a project, it requires that samples be taken after completion of mixing but prior to site handling. Generally, this means that the concrete is sampled at the job site from the delivery truck, although sampling at the concrete plant after mixing is permitted.

Sampling at the point of placement in the forms may also be specified on occasions, generally to check on-site delivery methods, e.g. where concrete is being pumped long distances. Whilst sampling at this point is perfectly proper, the information obtained from such samples cannot be used to determine the quality of the concrete delivered to the site. The point at which concrete is sampled is an important factor in determining the use to which test information may be put.

To ensure that samples are representative of the concrete being delivered to the site, it is first necessary to ensure that they are collected in a random manner, i.e. the batches of concrete or delivery units from which the individual samples are taken must be selected randomly, e.g. by using a list of random numbers to select batches. Selection should never be made on what the concrete looks like as it is being discharged.

Secondly, the actual sampling must be done in the prescribed manner. When a consistency or slump test only is to be performed, the test sample will normally be taken from the delivery or mixer truck immediately after the first 0.2 m³ of concrete has been discharged.

For other tests, including consistency tests on concrete sampled from non-agitator delivery units or from other locations on the site, composite samples are used. These are samples obtained by taking three or more approximately equal increments during the whole of the discharge. (Increments are not taken during the first nor the last 0.2 m³ of the batch.) The increments are then mixed together to form a composite whole from which the sub-samples are taken for (consistency) testing and/or moulding of test specimens.

AS 1012.1 should be consulted for details of a number of other specific precautions which must be taken to ensure that composite samples are representative of the batch.

3 TESTS ON FRESH CONCRETE

3.1 GENERAL

A number of tests are carried out, more or less routinely, on fresh concrete. These are tests for its consistency, its air content, its mass per unit volume and, perhaps less routinely, its bleeding characteristics. Consistency does not refer, as might be supposed, to the uniformity of concrete, but rather to the ability of the concrete to hold its shape when unsupported and to do so without segregating or falling apart. The most commonly used test for this is the slump test.

The consistency of concrete is closely related to its workability, i.e. the ease with which it can be moulded and compacted. Since it is really the workability in which we are interested a range of tests have been devised to measure this property – but they are generally more difficult to carry out than the slump test. The latter has therefore retained its popularity although it measures only indirectly the workability of concrete.

Because the various test procedures used to determine the consistency and/or workability of concrete actually measure different parameters, it is not advisable to compare directly the results of one procedure with another. Certainly, the results obtained by one test procedure cannot be used to determine

compliance with a specification requirement based on another test procedure.

3.2 THE SLUMP TEST

The slump test is described in Section 25 'Properties of Concrete' and detailed in AS 1012.3.1. The test is carried out by filling a mould, in the shape of a truncated cone, with concrete and then withdrawing the mould. The amount by which the concrete subsides or 'slumps' is then measured (**Figure 26.1** and **Figure 26.2**).

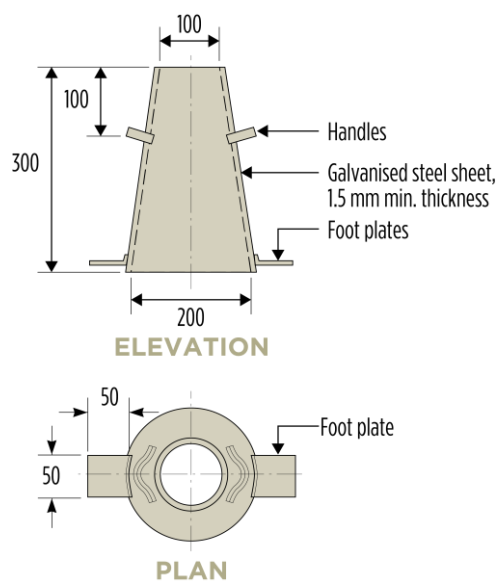

Figure 26.1 – Typical Mould for Slump Test

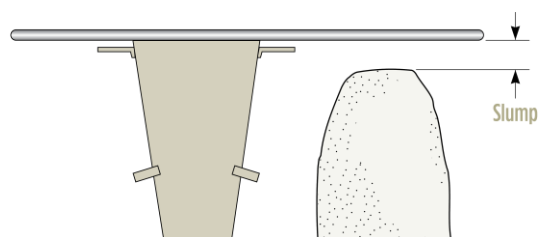

Figure 26.2 – Measuring the Slump

After the slump has been measured, the concrete is tapped gently on the side to obtain an indication of the cohesion of the mix. Mixes which are well proportioned and cohesive tend to subside a little further. Poorly proportioned, harsh mixes tend to fall apart.

The test does not work well for concrete with either very high or very low workability. Very

workable concretes may simply lose their shape completely by subsiding and flowing, while concretes of very low workability may not subside (slump) at all.

Some mixes may lack sufficient cohesion for the test to be carried out properly. The cone of concrete may shear or otherwise collapse as the mould is withdrawn. If this occurs, the test must be repeated with another part of the sample. If the concrete shears or collapses, the slump is not measured but a shear or lateral collapse is recorded (see **Figure 26.3**).

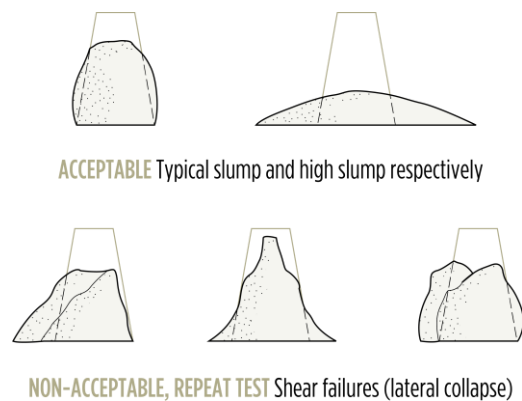

Figure 26.3 – Examples of Slump

3.3 THE COMPACTING FACTOR TEST

The compacting-factor test is generally regarded as a more direct indicator of the workability of concrete than the slump test. Moreover, it can be used on concretes for which the slump test is not suitable, e.g. concretes with very little or no slump. It is, however, quite sensitive to the early stiffening of concrete as hydration of the cement commences. In the laboratory it is normally carried out within four minutes of water being added to the mix. Obviously, this is not practical on site, but the sensitivity of the test to this factor should be recognised in interpreting the results.

The test is described in AS 1012.3.2 and is carried out by measuring the compaction achieved in a sample of concrete by performing a fixed amount of work on it. The apparatus is illustrated in **Figure 26.4**. The upper hopper is filled with concrete and then the trapdoor in the hopper opened, allowing the concrete to fall freely into the second or lower hopper. The trapdoor in this hopper is then opened, allowing

the concrete to fall into the cylinder. Excess concrete is struck off and the mass of concrete in the cylinder is determined. The cylinder is then emptied and refilled with a fresh portion of the sample under test, rodding or vibrating each layer of the concrete as it is placed in the cylinder to ensure that it is fully compacted. The mass of fully compacted concrete in the cylinder is then determined and the compacting factor calculated as the mass of concrete in the cylinder (when filled by falling from the hopper above) divided by the mass of concrete in the cylinder (when fully compacted). The higher this ratio then the more workable the concrete is.

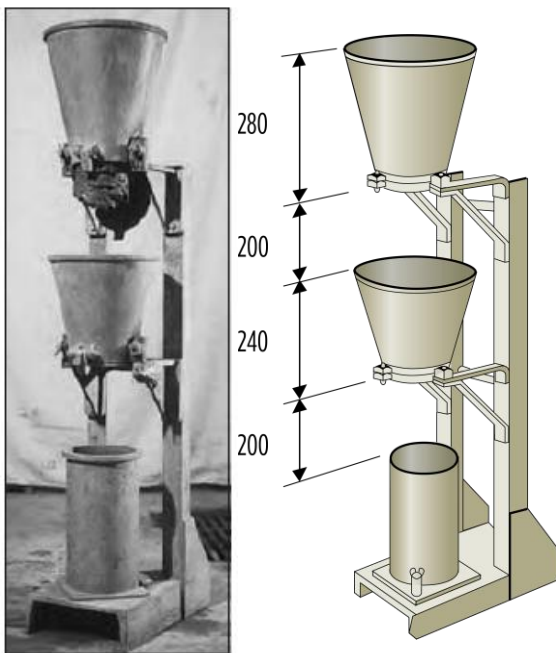

Figure 26.4 – Compacting Factor Test Apparatus

As was noted above, the test is quite sensitive, not only to early stiffening of the concrete but to the method of compaction used to fill the cylinder. This should be kept in mind when comparing results.

3.4 THE VEBE TEST

The 'Vebe' test is described in AS 1012.3.3. The equipment consists of a vibrating plate or table on which is mounted a metal cylinder inside which a conical mould or slump cone is placed (**Figure 26.5**).



Figure 26.5 – Vebe Consistometer

The test is carried out by determining the time taken for a cone of concrete (moulded with the slump cone) to subside completely inside the cylindrical mould when subjected to vibration. Whilst the test is sensitive to changes in materials, early stiffening of concrete and other factors which affect its workability, it is not easy to carry out with consistent results. Its application in the field is therefore limited but it has been used quite widely in the laboratory to investigate materials and their impact on workability. It works well for concrete having either very high or very low workability.

3.5 AIR CONTENT OF PLASTIC CONCRETE

Determination of the air content of plastic concrete may be necessary when the purposeful entrainment of air has been specified to enhance the durability of concrete or when it is desired to check the amount of air being entrained by admixtures used for other reasons, e.g. to improve workability.

Three methods of determining the air content of plastic concrete are described in AS 1012.4.1, AS 1012.4.2 and AS 1012.4.3. Two of these, based on determining the change in volume of a given quantity of concrete when subjected to

an increase in air pressure, are suitable for normal-weight, relatively dense aggregates. The third method, based on displacing the entrained air with water, is suitable when using lightweight and porous aggregates.

The two methods that apply pressure to the concrete, measure the reduction in the volume of air entrained within the concrete. From this figure and the pressure applied, the actual air content can be calculated. However, the equipment must be calibrated for the height above sea level at which it is being used and a correction may have to be applied for air contained within the aggregates. For this reason, it is not suitable for mixes containing porous aggregates **Figure 26.6**.

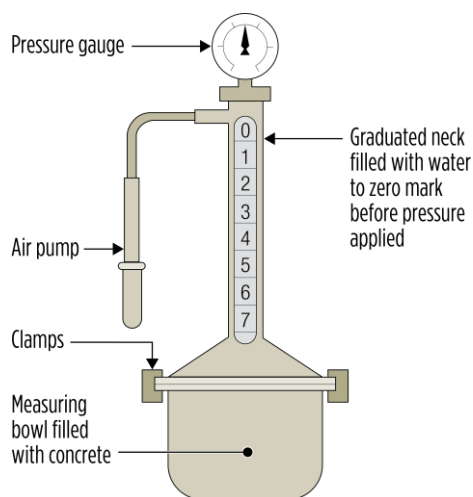

Figure 26.6 – Typical Arrangement of Apparatus for Determining Air Content of Concrete by Applied Air

The volumetric method entails the displacement of the entrained air with water. It is not necessary to calibrate the equipment for height above sea level or to correct for the air content of the aggregate. The test does, however, take longer to perform than the pressure methods (see **Figure 26.7**).

3.6 MASS PER UNIT VOLUME OF CONCRETE

The mass per unit volume (also called ‘plastic density’), of freshly mixed concrete is determined by a simple test in which the mass of concrete in a container of known volume is

measured. The standard procedure for conducting this test is described in AS 1012.5.

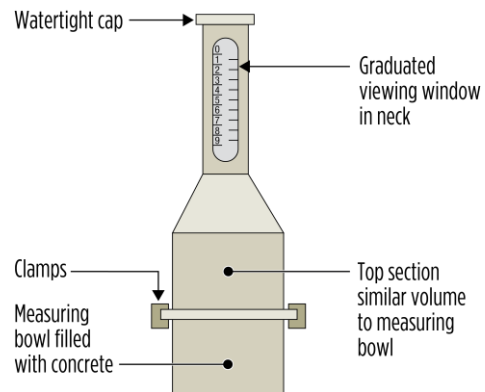

Figure 26.7 – Apparatus for Measuring Air Content of Fresh Concrete by Volumetric Method

Its principal application is the determination of the volume of plastic concrete produced from a given mass of constituent materials. The method for determining the volume of plastic concrete from the mass per unit volume of batches of a concrete mix is provided in AS 1379.

3.7 BLEEDING OF CONCRETE

Tests for the bleeding characteristics of concrete are normally carried out in the laboratory to evaluate trial mixes or to evaluate the influence of different materials, e.g. for the evaluation of admixtures under AS 1478.1. The actual procedure is described in AS 1012.6. A sample of the concrete to be tested is placed in a cylindrical container and compacted, either by rodding it or by vibration. The container is then covered and placed on a level surface. Bleed water is drawn off with a pipette at regular intervals until the amount collected during a 30-minute period is less than 5 mL.

The results may be expressed either as the volume of bleed water collected in a given time per unit surface area of the container, or as a percentage of bleed water to total mixing water if the latter is known.

3.8 SETTING TIME OF CONCRETE

Tests for the setting time characteristics of concrete are normally carried out in the laboratory to evaluate trial mixes or to evaluate the influence of different admixtures or binders on hardening rate.

4 TESTS ON HARDENED CONCRETE

4.1 GENERAL

A variety of tests may be carried out on hardened concrete to determine its properties or to measure its performance under different service conditions. They range from relatively simple tests to determine (say) the strength of the concrete to more-sophisticated and more expensive tests to determine (say) its fire resistance; and from tests which can be carried out quickly and without damage to the concrete, e.g. the Schmidt Rebound Hammer test, to those which may take months or even years to complete, e.g. long-term creep tests.

Viewed in another way, tests on hardened concrete fall into four groups, viz:

- Tests on specimens moulded for the purpose;
- Tests on cores taken from hardened concrete;
- Tests on concrete in situ;
- Tests on concrete elements.

Only tests in the first two categories are considered in any detail in this Guide. Tests in the other two categories usually require special equipment and special skills not normally found on a construction site. Three forms of concrete strength tests are described in AS 1012 Parts 9, 10 and 11 (the compressive strength test, the indirect tensile strength test, and the flexural strength test).

The first two are carried out on concrete cylinders and the last on concrete beams. Casting and curing of test specimens for these tests are described in AS 1012.8.1 (first two) and AS 1012.8.2 (for flexural test beams).

Also included are methods for determining the drying shrinkage and creep of concrete as well as a number of other tests.

4.2 TEST SPECIMENS

The need to standardise procedures for testing hardened concrete is every bit as important as that for testing plastic concrete. Thus, in addition to the care which must be taken in sampling concrete, care must also be taken in the preparation of test specimens. AS 1012.8.1 and AS 1012.8.2 describe the necessary procedures for moulding and curing compression, indirect tensile and flexural test specimens made from plastic concrete, respectively.

There is a common view that the making of test specimens is a simple procedure which can be entrusted to any site personnel. This is not so. Proper preparation requires proper training. It is therefore not unusual to find in concrete specifications a requirement that all site testing be carried out by a laboratory registered for the purpose by the National Association of Testing Authorities (NATA). Whilst it is not a mandatory requirement of the Standard, it helps to ensure that personnel making test specimens are trained for the task. NATA also manages a scheme for certifying personnel properly trained in sampling and testing concrete.

4.3 COMPRESSIVE STRENGTH TESTING

The determination of the compressive strength of concrete is described in AS 1012.9. It makes provision for two sizes of concrete cylinder to be used – either 150 mm-diameter × 300 mm-high, or 100 mm-diameter × 200 mm-high (see **Figure 26.8**). The smaller cylinder may be used provided the maximum aggregate size does not exceed 20 mm and the designer's permission is obtained. Whilst the two cylinder sizes tend to give the same average compressive strength, and hence may be used to determine compliance with the concrete specification, the coefficient of variation of the individual results may be different. Hence, results from the two

specimen sizes cannot be combined when determining the average strength.



Figure 26.8 – Moulds for the Two Standard Sizes of Concrete Test Cylinders

Cylinder tests are quite sensitive to the planeness of the ends and to the capping material used to ensure plane surfaces (see **Figure 26.9**). AS 1012.9 devotes considerable attention to this, setting quite stringent limits on the condition of the cylinder ends before capping and then on the materials and methods which may be used to cap cylinders. Alternative methods for treating the ends of cylinders are (a) to mill the cylinder ends, or alternatively (b) to use standard rubber caps. Reference should be made to the Standard for full details of each of these methods. The Standard also sets down requirements for testing machines (see **Figure 26.10**) and testing procedures to ensure that test results from a single batch of concrete are as uniform as possible.



Figure 26.9 – Sulphur Capped Concrete Test Cylinders in the Two Standards Sizes



Figure 26.10 – Test in Compression Machine

4.4 INDIRECT TENSILE STRENGTH TESTING

The indirect tensile strength, the Brazil or splitting test, is conducted on a standard 150 mm x 300 mm concrete cylinder (held in a jig – see **Figure 26.11**) by placing it horizontally in a testing machine and applying a compressive force to it. When tested in this way, the cylinder splits, enabling the tensile strength of the concrete to be determined. AS 1012.10 describes the procedure.

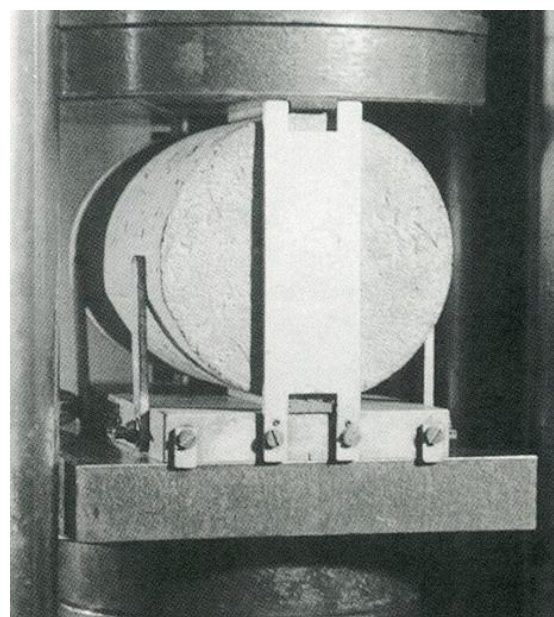

Figure 26.11 – Concrete Cylinder in Jig Ready for Indirect Tensile Strength Testing

4.5 FLEXURAL TENSILE STRENGTH TESTING

The specification of concrete flexural tensile strength is quite commonly used in pavements (aircraft pavements, concrete roads and some industrial pavements) where the strength of concrete in flexure, or bending, is of prime importance.

The most common test method is described in AS 1012.8.2 (for casting and curing) and AS 1012.11 (for flexural testing). The specimens are generally cast on site and the early curing of the specimens is critical to obtaining reliable test information. AS 1379 provides some guidance on the methods of assessing flexural strength data.

Test specimens are in the form of beams. The two common test beam sizes are provided in the Standard. The testing of the beams takes place in a 'four-point' test rig with the beam breaking between the two central loading points (see **Figure 26.12**).



Figure 26.12 – Flexural Testing Beam in Test Rig

For a given concrete, the flexure test gives a higher value for the tensile strength than the indirect tensile strength test and there is not a direct relationship between the two values. In specifying tensile strengths of concrete, care should therefore always be taken to nominate the method by which the value has to be obtained.

Further information on the tensile strength of concrete is provided in Part VIII, Section 25 of this Guide 'Properties of Concrete'.

4.6 DRYING SHRINKAGE TESTING

Limits on the drying shrinkage of concrete are commonly specified by designers in an attempt to limit both short-term and long-term movements in buildings and other structures and, thereby, the undesirable effects of such movements. For example, drying shrinkage can lead to unsightly cracking and, in extreme cases, loss of structural integrity.

Drying-shrinkage specimens may be prepared in the laboratory but are routinely prepared in the field to check the characteristics of concrete being delivered to the site.

Methods for the preparation and testing of drying shrinkage specimens are set out in AS 1012.8.4 (for casting and curing) and AS 1012.13 (for testing drying shrinkage).

The specimens required for the determination of drying shrinkage are prisms 75 x 75 x 285 mm with gauge studs set in either end (see **Figure 26.13**). The drying shrinkage of the specimen over time is determined by measuring the change in distance between the gauge studs after initial wet curing is complete and the specimens are placed in a standard drying environment (23°C and 50% relative humidity – similar to that in the interior of an air-conditioned office). Since drying shrinkage is susceptible to the initial curing of the specimens, particularly once they have been demoulded, it is essential that their curing is maintained in accordance with the testing Standard.



Figure 26.13 – Three Drying Shrinkage Specimens Cast in a Mould

4.7 CREEP TESTING

Limits on the creep of concrete may also be specified by designers in an attempt to limit both short- and long-term movements in buildings and other structures.

Whilst most creep specimens are prepared in the laboratory, they can be prepared in the field.

Methods for the determination of concrete creep are set out in AS 1012.16. The test is conducted on standard cylinders prepared in accordance with AS 1012.8.1. After a specified preliminary curing period a constant load is applied to the cylinders, which are stored in a controlled drying environment that is similar to that used in the drying shrinkage test. The change in their length with time is compared with that of companion cylinders which are unloaded (and subject to drying shrinkage). Both sets of specimens shrink. Hence, the difference between the two movements gives an estimate of the extent of creep in the loaded specimens (see **Figure 26.14**).

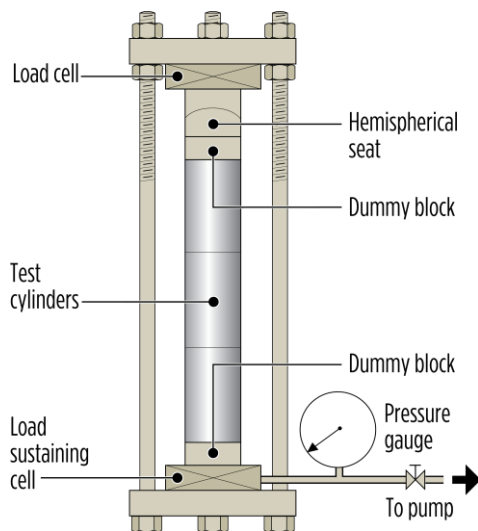

Figure 26.14 – A Typical Arrangement for Loading and Testing the Creep of Concrete Specimens

4.8 OTHER HARDENED CONCRETE TESTS

A number of other tests may be carried out on hardened concrete. These include the determination of its density (mass per unit volume) as a measure of its compaction, and the static-chord modulus of elasticity and Poisson's ratio (see **Figure 26.15**). All these

tests are based on the use of standard compression test cylinders, although the Standard does provide a method for determining the density of irregularly shaped specimens.



Figure 26.15 – Test Rig for Modulus of Elasticity

A chemical test, introduced in recent years to provide for requirements given in AS 3600 and AS 1379, is covered in AS 1012.20.1. Where aggregates contain chloride ions that are 'locked up' inside minerals that are part of the aggregate matrix then it is also useful to assess the water-soluble chloride of these aggregates using the method of AS 1012.20.2. This is intended to provide a method to demonstrate compliance with the requirements of AS 3600.

The requirements for the maximum chloride and sulfate content of hardened normal class concrete are detailed in AS 1379. The limits are:

- Sulfate: <50 gm per kilogram of cement;
- Chloride: <0.80 kg/m³.

In order to calculate these values, the tested mix needs to have a known cement content (kg/m³) and a tested mass per unit volume (see sub-section 3.6).

As mentioned earlier in this section, concrete may also be tested in-situ by means of a number of non-destructive tests. These range from the Schmidt rebound hammer (a device

which measures the surface hardness of concrete and thereby provides an estimate of its strength), to ultrasonic pulse velocity tests (which measure the time taken for an ultrasonic pulse to travel a measured distance through the concrete). An estimate of the strength of the concrete can be obtained given some knowledge of its constituent materials, their proportions and the moisture content of the concrete at the time of test.

Other tests are available to estimate the position of reinforcement in concrete and its potential to corrode.

In general, non-destructive tests are seldom used to ensure compliance with a specification. Nevertheless, they can be useful on occasions to provide information on the behaviour of the member and/or its condition. Further information can be obtained from various sources.

5 QUALITY ASSURANCE OF CONCRETE

5.1 GENERAL

The terms Quality Assurance (QA) and Quality Control (QC) are frequently confused as the activities do overlap. Quality Control is more about inspection and testing of a product. Quality Assurance is more about proving to the customer that adequate systems and processes are in place to ensure a product is fit for purpose, with consistent and predictable properties.

Quality Assurance may be defined as:

All those planned and systematic actions necessary to provide adequate confidence that the customer is supplied a quality product or service.

Quality Control may be defined as:

The operational techniques and activities which achieve and sustain a quality of goods or services that will satisfy a given requirement.

The majority of companies producing concrete have a certified Quality Assurance (QA) system in place and have organised appropriate staff

training in that system. As a result, this section will not explore aspects of QA in detail, but will concentrate more on the quality control aspects and briefly touch on the statistical concepts that are used as part of the control of concrete supply in accordance with AS 1379.

5.2 CONCRETE QUALITY CONTROL

Concrete suppliers will typically have two systems used for QA. The general QA system that applies to the majority of supplied concrete that is largely targeted at compliance with the two key Standards, AS 3600 and AS 1379. Contained under the suppliers general Quality Assurance system there may also be 'Quality Plans' that are typically specific plans with details of procedural variations for specific customers or projects. This section will be focused on quality control for the more general QA system.

AS 3600 largely re-directs to AS 1379 for quality control of concrete. AS 1379 provides requirements that must be met for:

- Control of concrete ingredient quality;
- Process control;
- Product acceptance control.

Each of the normal ingredients are controlled through their individual standards such as cementitious material quality standards (AS 3972, AS 3582 Parts 1 to 3), aggregate quality standard (AS 2758.1), admixtures/additives quality standard (AS 1478.1) and mixing water impurities control (AS 1379). (Refer also to this Guide, Part II, Sections 1 to 5).

The requirements for process control are set out in AS 1379 and include – calibration of batching equipment, batching accuracy, uniformity of mixing and delivery time control.

Acceptance control measures are set out in AS 1379 and include plastic concrete properties (slump, air content, workability, temperature, yields etc.), hardened concrete properties (compressive strengths, acid-soluble chloride content, sulfate content, drying shrinkage etc.).

If the control of concrete ingredient quality and the process controls are functioning effectively

then action on acceptance control measures should be minimal. This is critical in the case of hardened concrete properties where some testing may not provide results for more than 28 days. Plastic property acceptance control can generally be acted on more immediately (e.g. concrete mix adjustment for unacceptable slump or air content variations).

5.3 STATISTICAL CONTROL MEASURES

Batches of a particular concrete mix are not identical due to variations in testing, the concrete ingredients and the amounts of ingredients measured into a batch. There are inherent variations in any manufacturing operation that must be recognised. Testing variations add to this and for testing, consideration must be given to both equipment and operator variations.

Therefore, it is understood that the results of concrete testing will vary, and the aim of good quality control is to minimise this variation. Analysis of the results statistically assists this process.

Statistical analysis forms the basis of the assessment of the acceptance of concrete compressive strength sample test results to the Australian Standards. Statistical analysis is characterised by two factors:

- Average compressive strength of samples being assessed;
- Standard Deviation of the strength of samples being assessed.

For example, the average (or mean) strength of 15 samples is simply the sum of all the strengths divided by 15. The Standard Deviation is a measure of the variation of the sample strengths from the average strength using a statistical formula provided in AS 1379 and based on formulae derived from use of the 'Normal Distribution'. A larger variability in test results will produce a higher standard deviation.

When carrying out statistical analysis on test data that varies randomly around an average value, it is common to use the principal and formulae associated with the 'Normal

Distribution' to estimate the acceptance of that data compared to a minimum or maximum limit. For example, where a large population of tests distributed around an average test result are plotted by graphing the number of tests with equal strength against the strength value, then a plot similar to that shown in **Figure 26.16** is obtained.

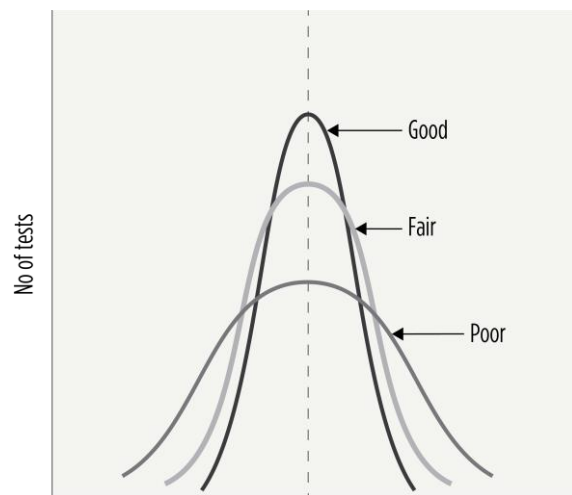

Figure 26.16 – Normal Distribution Related to QC

In **Figure 26.16** the graphs of three different Normal Distributions of test data are shown. The three distributions represent a 'good' (tight distribution around the mean) level of control, a 'fair' (moderate distribution around the mean) level of control and a 'poor' (wide distribution around the mean) level of control. Each of the three curves show a similar trend in that the frequency of occurrence of the same test results falls away as the test value is further away from the average (mean) value (i.e. the vertical line in the middle). The higher proportion of all test data is also closer to the average value in the case of 'good control' than it is for 'poor control'.

The structural designer is unlikely to be interested in the mean strength of concrete, as it is the characteristic strength (f'_c) that is of importance for design. Designers want some assurance that their concrete will not fail and that no more than 5% of compressive strength test results will be below f'_c .

To verify that concrete of a given grade strength meets the requirements of AS 1379, the average compressive strength (F_{cm}) of a set of

random samples of the concrete mix must be in excess of that required to achieve a specified characteristic strength – as defined in AS 1379. There is a complex relationship between the number of samples being assessed for a controlled strength grade (see sub-section 5.4), the estimated standard deviation of the sample strengths and the average of the sample strengths. This relationship is defined in AS 1379 and detailed further in the AS 1379 commentary – Supplement 1.

In simple terms the relationship is defined in the following equation:

$$F_{cm} \geq f'_c + k_c \times S \quad \dots \text{Eq.26.1}$$

Where:

- f'_c = Characteristic compressive strength;
- F_{cm} = The minimum average compressive strength of the sample;
- k_c = The statistical constant (Assessment Factor) based on the number of test samples being assessed for the controlled grade test samples;
- S = The standard deviation of the controlled grade sample being assessed.

From **Eq.26.1** it can be seen that a 'target' average strength for a concrete mix can be set by a supplier to ensure that random sets of compressive strength tests can be assessed as complying. This 'target' strength will be higher than the characteristic compressive strength for the grade. It can also be seen that a higher standard deviation will lead to a higher value for the minimum average strength and to a higher 'target' strength.

The values of k_c for differing numbers of controlled strength grade test samples are provided in **Table 26.1**.

The 'Target' compressive strength for a concrete mix is of more interest to the concrete supplier or mix designer. In applying quality control measures to concrete compressive strength at 28 days (or other age) the variation between the average strength of concrete over time is compared to the target strength to assess trends in the mix. The target strength is

always greater than the minimum average compressive strength but assumes that 15 or more tests are being assessed for the controlled grade (see sub-section 5.4).

The minimum 'target' compressive strength of a concrete mix is generally based on the following equation:

$$F_{ct} \geq f'_c + 1.65 \times S \quad \dots \text{Eq.26.2}$$

Where:

- f'_c = Characteristic compressive strength;
- F_{ct} = The minimum target compressive strength of the sample;
- S = The standard deviation of the controlled grade sample being assessed.

Table 26.1 – AS 1379 Assessment Factors for Different Numbers of Test Samples in a Controlled Grade

ASSESSMENT FACTOR k_c	
No. of test samples in controlled grade	Factor k_c
4 or less	3.2
5	2.5
6	2.1
7	1.9
8	1.7
9	1.5
10	1.5
11	1.4
12	1.4
13	1.3
14	1.3
15 or more	1.25

The value of '1.65' in **Eq.26.2** is derived from the normal distribution statistical formulae and approximates a value of F_{ct} where 95% of test data in a large population of tests will exceed f'_c .

If less than 15 tests are used to assess the controlled grade average strength and standard deviation, then the target strength of the mix will need to be increased to account for the uncertainty in standard deviation and average strength.

In summary, **Eq.26.1** is used for assessment of concrete compressive strength test data for acceptance and **Eq.26.2** is used by the supplier for setting the target strength for the compressive strength of each mix.

5.4 PRODUCTION ASSESSMENT OF CONCRETE

In AS 1379 there is recognition that a concrete supplier needs to be able to evaluate all strength grade concrete mixes supplied for compliance of compressive strength. Unfortunately, in any production interval, it is likely that very low volumes of some mixes may be produced and so very few test samples can be taken. In order to reduce the impact of this on the consistency of target strengths and mix design more generally, as well as better utilising the test data that is available, several concepts are built into AS 1379 production assessment requirements:

- Controlled grades and Associated grades;
- Grouping of supply plant test data;
- Estimation of Standard Deviation for associated grades;
- Minimum test frequency.

Controlled Grades

Where two or more mixes in a concrete plant or a grouped concrete plant have the same strength grade and are sufficiently similar in terms of ingredient sources, then the test data can be grouped together to calculate the average strength and standard deviation of what is referred to as the 'controlled grade' for a concrete plant or group of plants. The mix selection for this grouping will typically be the most commonly supplied or tested grades for the plant or group of plants. Assessment of controlled grade is made using **Eq.26.2** with S being equal to the controlled grade calculated standard deviation (S_c).

Grouping of Concrete Plants Test Data

Where two or more concrete plants use the same or very similar concrete mix ingredients and are subject to the same quality control procedures then it is possible to combine the data of mixes of the same strength grade to calculate the controlled strength grade standard deviation and various strength grade average strengths. This grouping is allowed provided each supply plant in the group provides a minimum of five test samples for each grade.

Associated Grades

All strength grade mixes in a concrete plant or group of concrete plants, other than the Controlled Grade, become what is referred to in AS 1379 as Associated Grades. The assessment of associated grades is carried out using a standard deviation that is derived from the plant or grouped plants-controlled grade standard deviation using the following equations:

$$F_{cm} \geq f'_c + k_c \times S_a \quad \dots \text{Eq.26.3}$$

$$S_a = R_f (\text{Associated grade}) \times S_c / R_f (\text{Controlled grade}) \quad \dots \text{Eq.26.4}$$

Where:

- f'_c = Characteristic compressive strength;
- F_{cm} = The minimum average compressive strength of the sample;
- k_c = The statistical constant (Assessment Factor) based on the number of test samples being assessed for the controlled grade test samples;
- S_a = The standard deviation of the associated grade sample being assessed;
- S_c = The standard deviation of the controlled grade sample being assessed;
- R_f = The 'Relative Factor' derived from AS 1379 and as shown in **Table 26.2** in this section with the R value for the Associated grade strength being divided by the R value for the Controlled strength grade.

Table 26.2 – Relative Factor for Calculation of the Associated Grade Standard Deviation

RELATIVE FACTOR R_f	
Strength Grade (MPa)	Factor R_f
20	1.0
25	1.1
32	1.2
40	1.3
50	1.4

Minimum Testing Frequency

AS 1379 requires that production control testing of concrete compressive strength is carried out at a frequency greater than 1 test per 100 m³ of each strength grade concrete produced over the production interval.

Production Interval

The production interval is the maximum period of time over which a supply plant test results can be assessed. AS 1379 indicates the production interval should be within a range of two weeks to three months and such that at least 10 samples from a plant or group of plants are available in that interval. For plants with production <1,000 m³ per three months the production interval used may be three months and the assessment based on the number of samples available in that interval.

Where there has been a considerable change in the mix designs or plant performance or upgrade, the supplier needs to start a new production interval from that date.

5.5 PROJECT ASSESSMENT OF CONCRETE

In AS 1379 it is also recognised that a project site owner, specifier, builder or contractor may wish to assess the concrete supplied specifically to that project site. In this case an underlying assumption of AS 1379 is that all strength grade concrete supplied to the site is subject to production assessment of concrete (even though it may not have been sampled on that site).

In this case there are three simple steps for assessment of compliance of project assessment of samples for each strength grade of concrete supplied during the project construction:

- Concrete is tested at a frequency of at least one test per 50 m³ of each strength grade of concrete;
- For each mix or strength grade of concrete, the average 28-day strength of any three consecutive test samples of concrete is equal to or greater than the characteristic strength of the concrete specified;
- If less than three test samples are available, then each test sample strength is greater than $0.85f_c$. Where test sample strengths are between $0.85f_c$ and f_c the supplier should be contacted for Production Assessment information to ensure that the concrete supplied was assessed as conforming during that period of supply and that there are no reasons for results below f_c other than random variations.

5.6 CONCRETE SUPPLIER MIX STRENGTH CONTROL

The concrete supplier will normally set up a system of early warnings based on predicted and actual 28-day compressive strength for groups of mixes that are similar and have the same target strength.

Often 1-day (accelerated curing), 3-day or 7-day strengths are used to predict trends in strength grade of these mixes.

Charting of strength results often includes predicted 28-day strength and actual 28-day strength. It gives a visual comparison of the accuracy of the formulae used for prediction as well as overall statistical compliance.

Individual test results are of little value in this process and it is common practice to use systems such as 'Shewhart Charts' or 'Cusum charts' to check that running averages of 5, 10 or 15 data points remain within acceptable ranges of the target strength. Both systems can be set up electronically to verify test data compliance within acceptable limits. A

characteristic of Shewhart charts is that running averages of test sample strength can be compared against the target strength as well as a statistically based upper control limit and lower control limit. The control limits vary depending on the number of tests assessed in determining the average value. Programming of the supplier's system can notify the supplier when action is required on the mix design to re-

align the mix strength to target (See **Figure 26.17**).

Details of the setup of Shewhart Charts and Cusum charts can be found in AS/NZS 3944 and AS 3940.

N32 GRADE COMPRESSIVE STRENGTH Vs. TIME SAMPLED (including moving average of 5 tests line)

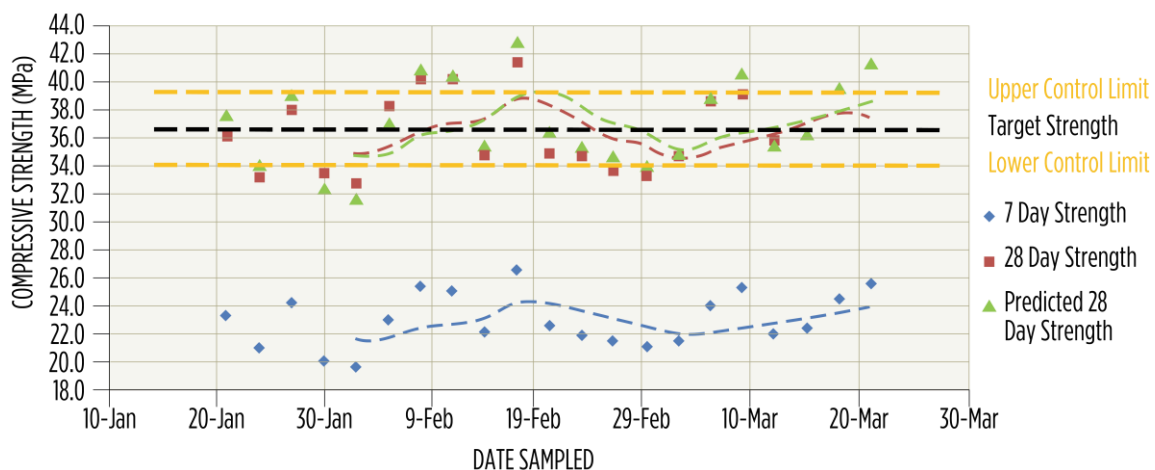

Figure 26.17 – Example of Shewhart Chart Analysis of N32 Grade Mix Test Data

6 QUALITY CONTROL OF TESTING OTHER THAN COMPRESSIVE STRENGTH

6.1 GENERAL

Any testing of concrete for plastic or hardened properties can be part of the quality control program of the concrete supplier. Such tests can include any of those discussed in this section, however AS 1379 refers to the following tests as having defined requirements:

- Slump Test;
- Mass per unit volume;
- Concrete compressive strength (7-day and 28-day);
- Indirect tensile strength;
- Modulus of rupture (Flexural tensile strength test);
- Air content;
- Sulfate and chloride content of concrete;

- Drying Shrinkage.

As noted, there are numerous other tests used to assess properties of concrete including many tests for durability of hardened concrete. The tests other than those specified in AS 1379 should be clearly specified by a designer and include a means of assessing the test results and any additional quality control requirements (such as control of W/C ratio during supply). The supplier will need to provide a quality plan to demonstrate the method of quality control proposed.

AS 3600 and AS 1379 assume a relationship between concrete strength and reinforcement cover in providing adequate durability of the concrete structure in a particular environment and so control of compressive strength is critical for durability performance under these standards.

The following sub sections discuss the specification of each test method provided in AS 1379.

Slump Test Specification

AS 1379 requires 'normal class' concrete to be specified by a 'target slump' or 'specified slump' between 20 mm and 120 mm (in 10 mm increments) as delivered to the customer's site. Slumps outside of this range may be specified but will then cause the concrete mix to be 'special class'.

The acceptable deviation in measured slump and target slump depends on the value of the target slump and the requirements of AS 1379 are shown in **Table 26.3**.

Table 26.3 – Permissible Tolerance on Slump for Ranges of Target or Specified Slump (as per AS 1379)

PERMISSIBLE TOLERANCE ON SLUMP	
Specified Slump, mm	Tolerance, mm
<60	±10
≥60 to ≤80	±15
>80 to ≤110	±20
>110 to ≤150	±30
>150	±40

A slump test measurement on site indicating an out-of-tolerance slump may lead to the rejection of the concrete unless re-testing or adjustment to the batch (addition of admixture or water within approved limits) produces a complying slump. Additions of water must be within agreed limits based on the supplier's quality control system and as allowed by the project specification.

Mass per Unit Volume Specification

The mass per unit volume test is called up in AS 1379 in several areas:

- The definition of normal class concrete;
- The assessment of the volume of concrete supplied;
- The mixer uniformity test.

The mass per unit volume of normal class concrete must be assessed and remain within

a range of 2,100 kg/m³ and 2,800 kg/m³. Concrete with a mass per unit volume exceeding this range will automatically become special class dense weight concrete. Concrete with a mass per unit volume lower than 2,100 kg/ m³ will be special class light-weight concrete.

The volume of plastic concrete delivered must be as per the supplier's certificate (docket or ticket with each delivered batch). AS 1379 requires that the combined total mass of all ingredients that are contained in a batch of concrete, divided by the supplier's certificate volume, must be more than 98% of the average mass per unit volume of the concrete mix measured using the mass per unit volume of three samples of the same concrete mix. The value of this calculation is often referred to as the 'yield' of the concrete mix. Concrete suppliers are required to carefully monitor yield to ensure compliance with AS 1379. Non-conforming yields are simply remedied by proportionately increasing or decreasing all of the ingredients in an otherwise acceptable mix design.

AS 1379 provides a measure of the performance of a concrete mixer following a standard mixing cycle by comparing two samples of concrete during discharge from the mixer (ideally in the first 10% and last 10% of a discharge stream). A number of factors are assessed including slump, air content, coarse aggregate content and plastic concrete mass per unit volume. The acceptable range in mass per unit volume between the two samples is 'not greater than 50 kg/m³'.

Compressive Strength at 7-Days

The assessment of 28-day strength of concrete has been covered in clause 5 of this section. AS 1379 does have requirements for minimum strength at 7 days as well as requirements for compressive strength compliance at 28 days.

The early strength requirements of AS 1379 were introduced to ensure that minimum early strength was achieved for a given characteristic 28-day strength so as to support minimum curing and stripping requirements of AS 3600. In previous standards the alternative method used was to limit the use of SCM's as they have an impact on early strength growth.



The requirements of AS 1379 are based on a limit to the average (or 'mean') 7-day compressive strength of a normal class strength grade. These limits are repeated in **Table 26.4**. This approach allowed concrete producers to better optimise the use of SCM's in their mix design.

Table 26.4 – Minimum Average 7-Day Strength for f_c Required by AS 1379

MINIMUM MEAN 7-DAY COMPRESSIVE STRENGTH FOR NORMAL CLASS CONCRETE	
Grade Designation	Mean 7-day strength (MPa)
N20	9
N25	12
N32	16
N40	20
N50	25

Flexural and Indirect Tensile Strength

The assessment of both of the tensile strength tests are discussed in AS 1379. The recommended method in the Standard is to carry out an assessment of the tensile and compressive strengths on a range of concrete compressive strength mixes to capture the specified characteristic tensile strength of the required concrete. At least three different mixes using the same types of binder, coarse aggregate, sand and admixtures as proposed to be supplied in the final concrete mix are required for this test program. A 'best fit' relationship is determined between the tensile strength and compressive strength from this testing. From this relationship an equivalent 'characteristic' compressive strength for the specified characteristic tensile strength is estimated. Using this method allows for the compressive strength to be monitored on the mix so as to assure that the specific tensile strength has been achieved.

For example, the relationship between average compressive strength (f_{cm}) and average flexural tensile strength (f_{tm}) has been determined from tests on a set of materials to be as shown in **Eq.26.5**:

$$(f_{tm}) = 0.665 \times (f_{cm})^{0.5} \quad \dots \text{Eq.26.5}$$

If the specified characteristic flexural strength was specified as 4.0 MPa, then the equivalent characteristic compressive strength can be calculated as 36.2 MPa from **Eq.26.5**.

Alternative methods of assessing the compliance of a set of tensile strength testing data need to be carefully considered as determining the correct balance between supplier and consumer risk need to be taken account of and tensile strength testing is notoriously imprecise. (The typical coefficient of variation for tensile strength testing ranges from 50% to 100% greater than for compressive strength testing, and pair differences can be as high as 15-20% of the average tensile strength with no obvious reason for the difference. For compressive strength testing, pair differences are typically less than 5-10% of the average strength).

Air Content of Concrete

The air content of normal class concrete is required to have air content less than 5.0%. When air content is specified the concrete mix is automatically a special class. The measured value of air content must be within $\pm 1.5\%$ of the specified value.

In cases where an entrained air content of the concrete is critical (e.g. slip-form concrete) it is not abnormal for a specifier to limit the air content variation from the target value to $\pm 1.0\%$.

Air content of concrete is significantly impacted by ultra-fines in the concrete mix and particularly some organic materials in sand, active carbon in fly ash or silica fume and some clays present in aggregates (coarse and fine). Ensuring a high level of control on mix air content requires careful selection, monitoring and control of mix ingredients.

Correction to air content of a batch of concrete on site may be possible by increasing air entraining agent dose rate to increase air content or using an air de-training admixture to decrease excessive air content (e.g. tri butyl phosphate or similar but note that material safety issues and safe handling requirements are critical for this chemical). Where air content

of a concrete mix is critical the testing frequency may need to increase until stable air content is achieved. AS 1379 recommends a test frequency of at least 1 test per 100 m³ but in some cases testing may need to be more frequent, particularly in the first batches supplied to a site.

Sulfate and Chloride Content of Concrete

AS 1379 and AS 3600 set limits on the maximum chloride and sulfate content of concrete. Testing of hardened concrete is generally carried out to AS 1012.20.1 or AS 1012.20.2 (see sub-section 4.8).

AS 1379 requires the concrete supplier to assess the sulfate and chloride content of concrete on the controlled grade concrete mix in a supply plant at least once every six months.

Drying Shrinkage of Concrete

AS 1379 requires that testing drying shrinkage at 56 days is carried out on the controlled grade concrete mix in a supply plant at least once every six months. The maximum individual test sample drying shrinkage at 56 days is 1,000 microstrain. In order to guarantee this the average or target drying shrinkage will need to be much less than 1,000 microstrain.

AS 3600 predicts that the average drying shrinkage value at 56 days (when tested to AS 1012.13) will range from 750 microstrain to 800 microstrain depending on the strength grade. These values are not out of step with those of AS 1379 as the standard deviation of drying shrinkage testing at 56 days may range from 80 microstrain to 150 microstrain. In view of this a maximum individual test sample having a probability of exceeding 1,000 microstrain at 56-day drying is less than 5%.

More information on drying shrinkage is provided in Part VIII, Section 25 of this Guide.

7. REFERENCES

- 1) AS 3600 – *Concrete structures*
- 2) AS 1379 – *Specification and supply of concrete*
- 3) AS 1012, Parts 1 to 20 – *Methods of testing concrete*:
 - Part 1 – *Sampling of concrete*
 - Part 3.1 – *Slump test*
 - Part 3.2 – *Compacting factor test*
 - Part 3.3 – *Vebe test*
 - Part 4.1 – *Determination of air content of freshly mixed concrete – Measuring reduction in concrete volume with increased air pressure*
 - Part 4.2 – *Determination of air content of freshly mixed concrete – Measuring reduction in air pressure in chamber above concrete*
 - Part 4.3 – *Determination of air content of freshly mixed concrete – Measuring air volume when concrete dispersed in water*
 - Part 5 – *Method for the determination of mass per unit volume of freshly mixed concrete*
 - Part 6 – *Method for the determination of bleeding of concrete*
 - Part 8.1 – *Method for making and curing concrete – Compression and indirect tensile test specimens*
 - Part 8.2 – *Method for making and curing concrete – Flexure test specimens in the laboratory or in the field*
 - Part 8.4 – *Drying shrinkage specimens prepared in the field or in the laboratory*

- Part 9 – *Compressive strength tests – Concrete, mortar and grout specimens*
 - Part 10 – *Determination of indirect tensile strength of concrete cylinders*
 - Part 11 – *Determination of the modulus of rupture*
 - Part 13 – *Determination of the drying shrinkage of concrete for samples prepared in the field or in the laboratory*
 - Part 16 – *Determination of creep of concrete cylinders in compression*
 - Part 20.1 – *Determination of chloride and sulfate in hardened concrete and aggregates – Nitric acid extraction method*
 - Part 20.2 – *Determination of water-soluble chloride in aggregates and hardened concrete*
- 4) AS 1478.1 – *Chemical admixtures for concrete, mortar and grout – Admixtures for concrete*
 - 5) AS 3972 – *General purpose and blended cements*
 - 6) AS 3582, Parts 1 to 3 – *Supplementary cementitious materials for use with Portland and blended cement*
 - 7) AS 2758.1 – *Aggregates and rock for engineering purposes – Concrete aggregate*
 - 8) AS/NZS 3944 – *Shewhart control charts*
 - 9) AS 3940 – *Quality control – Guide to the use of control chart methods including Cusum techniques*
-

GUIDE TO CONCRETE CONSTRUCTION

T41



CEMENT CONCRETE
& AGGREGATES AUSTRALIA

PART IX - Related Site Practices

Formwork has a dual function in concrete construction – it supports the plastic and hardening concrete until it is sufficiently strong to support the actions/loads imposed upon it, and it imparts a finish to the concrete surface. This Section describes the different types of formwork used in modern concrete construction and outlines the requirements which must be met for formwork to perform satisfactorily. The special requirements associated with the achievement of visually satisfying surface finishes are discussed in Part V, Section 16 ‘Control of Surface Finishes’ in this Guide.

CONTENTS

1. INTRODUCTION	2	7.2 UNDISTURBED SHORES.....	12
2. BASIC COMPONENTS OF FORMWORK	3	7.3 RESHORING SYSTEMS.....	13
3. REQUIREMENTS FOR FORMWORK ...	4	8. CONSTRUCTION OF FORMWORK ...	13
3.1 GENERAL	4	8.1 ERECTION	13
3.2 STRENGTH.....	4	8.2 PREPARATION FOR CONCRETING.....	13
3.3 STIFFNESS.....	5	8.3 EXTERNAL VIBRATION	14
3.4 ACCURACY	5	8.4 STRIPPING FORMWORK.....	15
3.5 WATER-TIGHTNESS	5	9. FORMWORK DOCUMENTATION	15
3.6 PERMEABILITY.....	5	10. SUMMARY – CONSTRUCTION CHECKLIST	17
3.7 ROBUSTNESS.....	5	11. RELEVANT AUSTRALIAN STANDARDS	18
3.8 EASE OF STRIPPING.....	6		
3.9 STANDARDISATION.....	6		
3.10 SAFETY	6		
4. MATERIALS FOR FORMWORK.....	6		
4.1 GENERAL	6		
4.2 CHOICE OF MATERIALS.....	6		
4.3 FORM LINERS.....	7		
5. FORMWORK SYSTEMS	8		
5.1 MODULAR FORMWORK	8		
5.2 GANG FORMS.....	8		
5.3 TABLE FORMS.....	8		
5.4 JUMP/CLIMB FORMS	9		
5.5 SLIP-FORMS.....	9		
5.6 PERMANENT FORMWORK.....	10		
6. DESIGN OF FORMWORK.....	10		
6.1 GENERAL	10		
6.2 LOADS ON FORMWORK.....	10		
7. FALSEWORK.....	12		
7.1 DESIGN OF SUPPORT STRUCTURES.....	12		

1. INTRODUCTION

Formwork is the temporary structure which (a) moulds concrete into the desired shape and (b) holds it in the correct position until it is able to support the loads imposed upon it. It also imparts the required surface finish. Importantly, formwork also provides safe working areas and access ways for construction personnel. Formwork and its supports (known as falsework) is a structural system and must be designed and built accordingly. The actions (loads) imposed on it may be temporary, but they can be extremely large. Frequently they are different in nature to those imposed on the finished concrete structure.

Concrete is an extremely plastic and mouldable material which will accurately reflect the shape, texture and finish of the surface against which it is cast. Any imperfection or inaccuracy in this surface will be indelibly inscribed onto the concrete surface. Form-face materials must therefore be chosen both to achieve the required surface finish and, in conjunction with all the supporting elements, to maintain

accuracy and stability under all of the loads imposed during erection and placing – typically for at least several days into the life of the concrete structure.

At early ages, the concrete will not be able to support the loads imposed on it. Until the concrete is able to support the imposed loads the formwork (and falsework) will be the primary loadbearing structure. Only when the concrete has achieved sufficient strength can the formwork be removed without detriment to the safety or performance of the concrete structure.

Failure to meet accuracy, stability and strength requirements will lead to formwork failures in the form of bowing, warping or misalignment which will be reflected in the final structure. Such problems could even lead to the catastrophic collapse of part (or all) of the formwork.

The cost of formwork is generally a very significant item in the overall cost of a project. The formwork system should be the most economical available – but cost concerns should never be permitted to overrule the criteria governing safety, strength and stability. In reality, the initial cost of formwork may be a very poor guide to its suitability for a project. Multiple uses of good quality formwork can result in improved overall project economies. Formwork design and selection of materials should therefore always be approached on the basis of ‘cost per use’.

2. BASIC COMPONENTS OF FORMWORK

The basic components of formwork for typical concrete elements are shown in **Figures 27.1 to 27.4**.

The basic structure of almost all formwork is the same. It comprises:

- Form-face – which creates the surface finish e.g. metal or plywood sheet, sawn timber;
- Studs, or joists – lengths of sawn timber or (sometimes) metal sections which support the form-face and prevent it from bulging or bowing in one direction; and

- Walers or bearers – which brace the studs or support the joists and prevent bulging or bowing in the other direction.

An important facet of formwork design and construction is the choice of spans (or centres) between studs, and also centres between walers or bearers – both of which are important in preventing bulging and bowing.

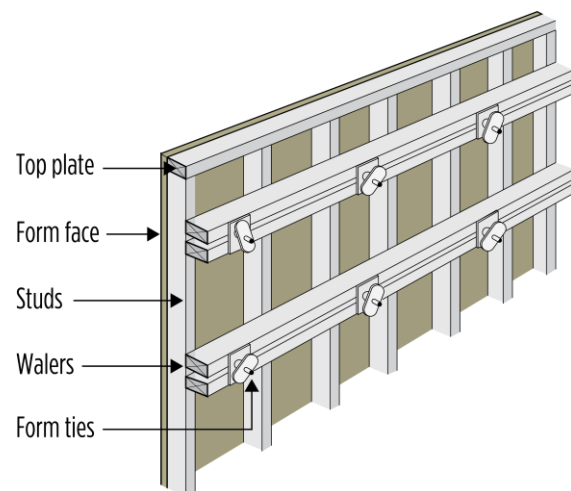

Figure 27.1 – Wall Forms

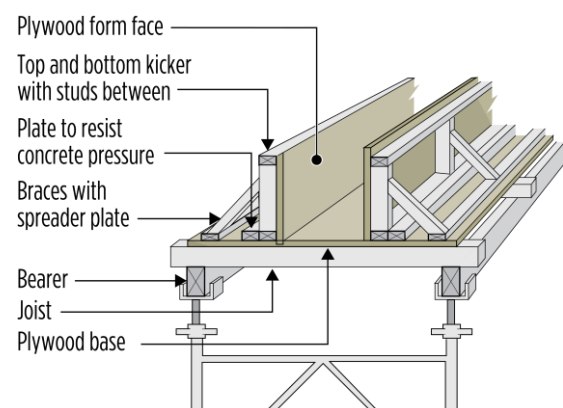

Figure 27.2 – Beam Form and Supports

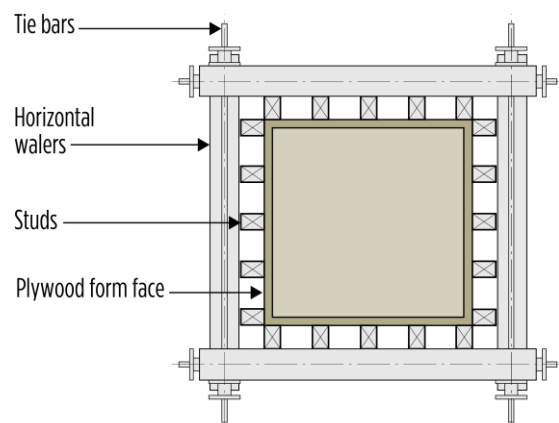

Figure 27.3 – Column Forms

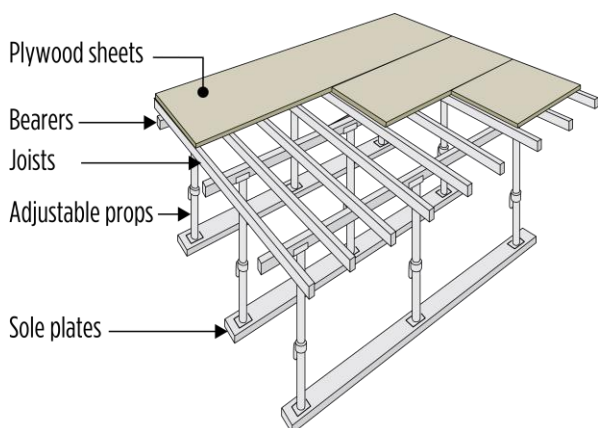

Figure 27.4 – Typical Soffit Forms and Falsework (diagrammatic only; bracing not shown)

3. REQUIREMENTS FOR FORMWORK

3.1 GENERAL

Although formwork is constructed only to contain and support concrete until the cast structure is strong enough to support the imposed loads itself, it must provide a safe environment for all those working on or around it. In addition to being strong enough, it must also be stable against overturning, uplift, and sideways movements. It must also meet all statutory requirements for access ladders, guardrails, working platforms, etc. Where Importance Level II and Importance Level III criteria (see AS 3610.1 – Appendix A) are met, formwork documentation that (a) sets out the requirements of the formwork design, (b) states that the design conforms with AS 3610 requirements, and (c) allows the formwork to be verified and inspected, is a mandatory requirement of AS 3610. Where proprietary formwork systems are used, formwork documentation can contain brochures describing the formwork – provided these contain a suite of information described in AS 3610 (see also sub-section 9).

The general requirements for formwork are summarised in **Table 27.1**. Additional information is contained in AS 3610.

With new materials, these requirements may be readily met. With re-use, all materials (except perhaps metal components) may be weakened.

However, even metal components may become loose fitting or broken due to wear. All formwork materials and components must be checked regularly to ensure that they are sound and safe.

Table 27.1 – Requirements for Formwork

Property	Purpose
Strength	Carry imposed loads
Stiffness	Maintain specified shape and avoid distortion of concrete elements
Accuracy	Ensure shape and size of concrete elements; Ensure specified cover to reinforcement.
Watertightness	Avoid grout loss and subsequent honeycombing of the concrete
Permeability	When used, permeable formwork allows water and air to be removed from the formed surface
Robustness	Enable re-use
Ease of stripping	Avoid damage to concrete surfaces
Standardisation	Promote economy
Safety	Ensure a safe working environment

3.2 STRENGTH

All components should be designed to cater for the most severe loads that are likely to be imposed on the formwork. To achieve this, the formwork design should be carried out by a person experienced and competent in such design.

Care should then be taken to ensure that the design details are met and that the construction loads imposed on the formwork are within the limits nominated by the designer.

Sound materials should always be used. Re-used material may be satisfactory but should be checked regularly to ensure it is in good condition and adequate for the job in hand. The strength of each item of formwork material contributes to the overall safety of the temporary structure.

Particular care is required with formwork design and application where flowing concrete (also known as Super Workable Concrete or Self Compacting Concrete – see Section 22 ‘*Super-Workable Concrete*’ in this Guide) as these materials can exert full hydrostatic pressure on the formwork, resulting in significantly higher pressures on the formwork than are seen with conventional ‘slumped’ concrete. This is particularly the case for formwork in vertical structures such as columns and walls.

3.3 STIFFNESS

Formwork should not bow, bulge, sag or otherwise move to the extent that the completed concrete element falls outside the tolerances specified for the work.

The formwork designer should detail the formwork elements to have adequate stiffness, but site personnel are responsible for ensuring that (a) the correct materials are used, (b) they are of adequate quality, and (c) they are used in the proper manner. For example – plywood sheeting for general formwork use has a greater strength in one direction relative to the other. It should always be used in the correct orientation, as shown in **Figure 27.5**.

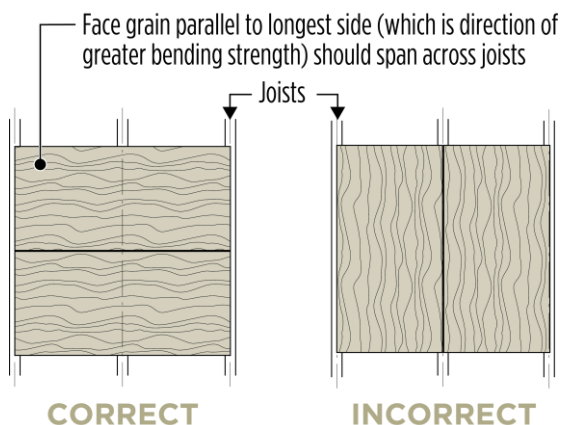

Figure 27.5 – Orientation of Plywood

3.4 ACCURACY

In general, formwork should always be built to an accuracy greater than that desired in the finished concrete structure or element. All support structures should be sufficient to ensure that this accuracy is maintained until the concrete has hardened.

The accuracy required may affect the selection of the material from which the formwork is to be built, as some materials may be able to be assembled to tighter tolerances than others.

3.5 WATER-TIGHTNESS

All joints should be sealed to stop grout (cement and water) leaking from the formwork. Grout loss causes ragged edges, hydration staining and honeycombing which can affect strength, durability and appearance in the final structure. These issues can be exacerbated when using flowing concretes of the types described in sub-section 3.2.

3.6 PERMEABILITY

Systems using formwork with high permeability have some advantages. There are several systems available, but they may be as simple as a fabric material attached to plywood backing which contains drain holes. This type of formwork allows ‘bleed’ water and air to escape through the formed faces with the effects of (a) lowering W/C ratio in the areas adjacent (to a depth of about 20 mm) to the formwork, (b) increasing the strength and reducing sorptivity and permeability in these outer areas, and (c) improving the finish at these surfaces.

3.7 ROBUSTNESS

Formwork should be robust enough to withstand repeated stripping, storing and erection. Re-use of formwork is an important element in improving the overall economy of the structure. The extent of possible re-use varies with formwork materials – with ranges from ‘up to 5 times’ for plywood to 20-30 times for fibreglass and 50-100 times for steel. For form liners (see 4.3), re-use can vary from 1-20 times

for timber (with varying surface treatments) to up to 100 times for rubber.

3.8 EASE OF STRIPPING

Formwork should be easy to remove – to avoid or minimise damage to the concrete and/or to the forms. Consideration should therefore be given to providing adequate draw (taper) on vertical faces and also to the movement which must be allowed in supports to facilitate easy removal of horizontal soffit forms and specialist systems such as table forms.

3.9 STANDARDISATION

As far as possible, formwork components should be standardised in size to avoid unnecessary cutting. They should be able to be stripped, shifted and re-erected rapidly if speed of construction is to be maintained. This necessitates a system that comes apart easily, has a minimum of elements needing to be replaced (i.e. those damaged during removal) and is easily shifted with the available equipment. On small jobs this will involve 'manhandling', but on large jobs crane capacity may be used to improve efficiencies.

Standardisation for speed of construction frequently requires more expensive formwork but, once re-use is taken into account, lower overall project costs can be achieved.

3.10 SAFETY

Formwork must provide a safe working environment for all those working on and around it. In addition to being of adequate strength, it must also be stable against overturning, uplift, and sideways or sliding movements. Properly guarded walkways should be provided around all areas of suspended work to provide safe access to them during construction, as should a safe means of withdrawal as concreting progresses. All statutory requirements must be met.

The tightness of all components must be thoroughly checked prior to pouring concrete.

The stripping procedures (see 8.4) specified must not be modified and limits placed on stacked materials anywhere on the formwork must not be exceeded.

4. MATERIALS FOR FORMWORK

4.1 GENERAL

Formwork can be constructed in a variety of ways and from a number of materials. The size and nature of the project will most likely determine which materials and which systems are likely to maximise technical and economic imperatives. For example, on some projects, particularly small ones, certain formwork elements are likely to be used only a relatively small number of times. Considerable cutting and fitting may be involved with consequent wastage of materials. The use of lower grade/cost materials may then be justified – provided safety is not jeopardised.

On larger projects, or with multiple projects, the use of specifically designed and constructed formwork elements can lead to improved economy. Standardisation and interchangeability then become particularly important selection criteria.

4.2 CHOICE OF MATERIALS

Many materials may be used for formwork. **Table 27.2** provides a brief overview of the characteristics of those in common use.

Before the final selection of the formwork material is made for a particular project, a number of factors should be considered, including:

- The size of the forms;
- The shape of the forms;
- The surface finish quality required;
- The accuracy required;
- The number of re-uses required;
- The handling methods proposed;
- The methods of compaction proposed;
- The methods of curing proposed; and
- Safety.

The weighting given to each factor will vary from project to project. On small projects, where multiple uses of formwork elements are unlikely and a great deal of cutting and fitting may be required, timber sections may well be appropriate. On major projects, where standardised components can be employed and multiple re-use achieved, heavier steel sections may well be warranted. Modular units may also be viable in such circumstances. In the final analysis, the choice of formwork materials is a matter of cost, suitability and availability. Most of the commonly accepted materials can be made to work in most situations. The quality of the finish required, and the overall cost of the formwork, are likely to be the principal determinants in choosing materials.

4.3 FORM LINERS

Form liners are effectively a mould placed on the inside of formwork and are used to create simple or complex designs or textures on the surface of concrete (Figure 27.6). The use of form liners has expanded the architectural applications of concrete hugely, and it is really open to the designer to create as complex a pattern as can reasonably be imposed on a concrete surface. When combined with coloured concrete the architectural scope expands even further. A wide variety of materials can be used as form liners, with important considerations being (a) the complexity of the design required, and (b) the extent of re-use of the form liner that is required. For low levels of re-use materials like cardboard, rigid plastics, polystyrene or tempered hardboard have been used. These will generally only provide one or two castings. For high levels of re-use, rubbers and synthetic polymers are common. Patterns can also be created when form liners are coated (partially) with a retarding agent to create different

textures and patterns on the concrete surface – typically a scene or portrait.

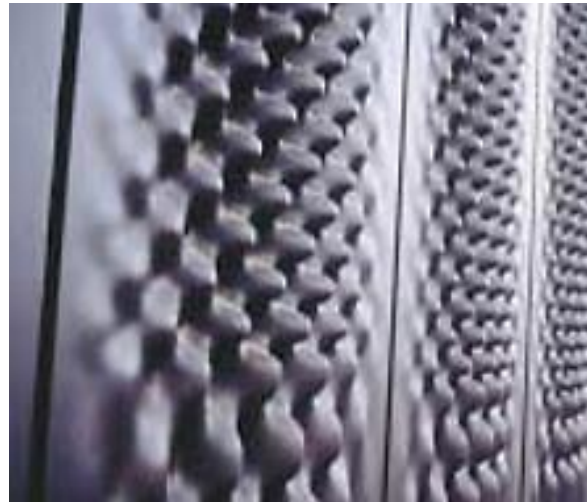

(a)

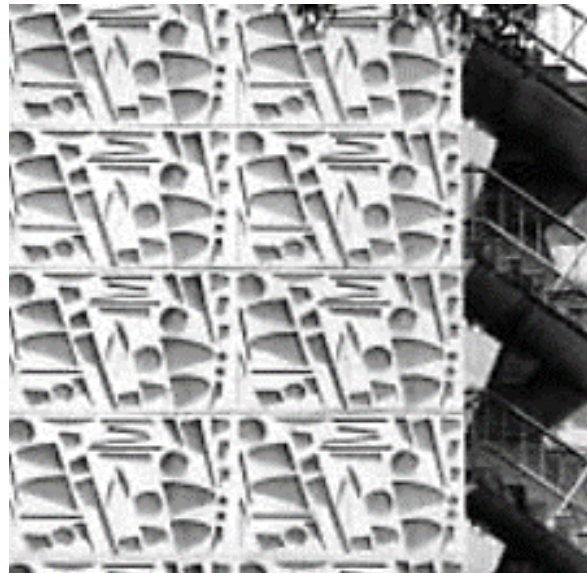

(b)

Figure 27.6 – Variety of Textures and Patterns achieved by Using Form Liners

Detailed information on the use of form liners and their range of applicability is given in the CCAA Briefing 06 'Form Liners – Achieving Surface Relief and Texture' (June 2002).

Table 27.2 – Formwork Materials

Material	Uses
Timber	Commonly used for studs, bearers, joists, walers etc. as it is readily available and easily worked with conventional tools. Has good load-carrying capacity and some suitable species are relatively light-weight, e.g. Oregon. Australian hardwoods tend to be heavier and more susceptible to warping. Some species of pine also tend to splinter or split when nailed.
Steel	Steel sections are used in formwork framing, particularly in patented systems. Strong and robust, steel-framed formwork is capable of multiple re-uses but requires a degree of standardisation to warrant its additional cost. It is commonly used in precasting yards, particularly for repetitive work.
Coated plywood	Commonly used for soffits or as form liners in beams, columns and similar elements. Readily worked, coated plywood (properly handled) is capable of multiple re-uses.
Cardboard	Has been used in column and waffle forms. Normally suitable for one-off use only.
Glass reinforced concrete (GRC) or plastic	Commonly used as permanent formwork, where it provides a decorative finish, or in moulds to achieve intricate shapes – particularly for precast elements. Generally, it is relatively durable and capable of multiple re-uses.
Concrete	Precast concrete elements are used as permanent formwork – where the precast element is exposed to view in the completed structure. Also used to provide permanent forms in precast concrete factories where it is very economical for standard elements or components.
Rubber, thermoplastic and polystyrene materials	Used as form liners to provide intricate effects and for decorative finishes. Rubber and thermoplastic sheeting are used for decorative finishes and are suitable for multiple uses.

5. FORMWORK SYSTEMS

5.1 MODULAR FORMWORK

A number of formwork systems comprising modular units are available on a sale or hire basis. The systems generally incorporate modular panels so that they can be re-used on a wide variety of jobs. Panels may use a steel frame with plywood facing which can be replaced when necessary. Generally, such systems incorporate simple but effective means of support and fixing.

5.2 GANG FORMS

Gang forms are individual components, often modular, made up into large panels that are then tied and braced so that they can be moved as a complete unit.

Adequate crantage is essential for handling gang forms but the cost of the crantage is offset by the increased speed of construction offered by moving large units of formwork from one location to another.

5.3 TABLE FORMS

Table forms are a type of gang form used to form soffits. Large sections of soffit form, complete with propping and bracing elements, can be fabricated into a single unit which, after use, can be lowered from the soffit, transported to the edge of the floor, lifted to the next level by the crane and realigned ready for the next concrete placement (**Figure 27.7**).



Figure 27.7 – Typical Use of Table Forms

A 'transporter' is often used to wheel the table forms to the edge of the building, where a special rig enables the crane to handle them efficiently.

Table form systems are of particular use in multi-storey building construction where speed is important, adequate cranning is available and the initial cost of formwork can be offset by multiple re-uses.

5.4 JUMP/CLIMB FORMS

Jump or climb forms are gang forms for casting vertical elements such as walls and shafts. They are equipped with simple and rapid mechanical means of handling, require a minimum of labour and do not rely on the availability of cranning (Figure 27.8).

The system strips the form, shifts it to the new position and then re-aligns it using its own inbuilt jacking system. Daily casting cycles are common.

Jump or climb form systems are capable of producing a high-quality finish with good colour control.

5.5 SLIP-FORMS

Slipform systems incorporate continuously moving formwork to speed construction and to eliminate the need for large areas of formwork. The concrete being 'extruded' must have adequate stiffness to hold its shape once it is

free from the slipform. Slip-forming can be undertaken either vertically (e.g. for silos, towers and lift shafts) or horizontally (e.g. for roads and safety barriers).



Figure 27.8 – Typical Self-climbing Formwork System

On vertical elements, the slipform has shutters on both faces that are lifted vertically, at a predetermined rate by a series of hydraulic jacks (Figure 27.9). Typical rates of slip-forming vary from 300-400 mm per hour. Some projects are slip-formed continuously, whilst on others the free-standing height is limited to a few storeys.

Slip-forming is not recommended where a high degree of colour control on the finished surface is necessary as colour banding is very difficult to avoid.

On horizontal construction, it can be used in its most simple form to construct kerbs and channels and, in the more sophisticated form, to construct roads or channel linings. Horizontal paving rates of up to 2 km per day have been achieved on large projects but an average rate of 300-500 m per day is more common. No edge forming is generally used for this work and the concrete must be made to a consistency sufficient to avoid slumping once it is free of the machine. Slip-forming is discussed in more detail in Section 19 'Slip-formed Concrete' of this Guide.



Figure 27.9 – Slip-forming a Vertical Element

5.6 PERMANENT FORMWORK

Permanent formwork is a type of formwork which is left in place to become part of the finished structure (**Figure 27.10**). It may assist in taking some of the structural load or simply provide a permanent decorative finish.

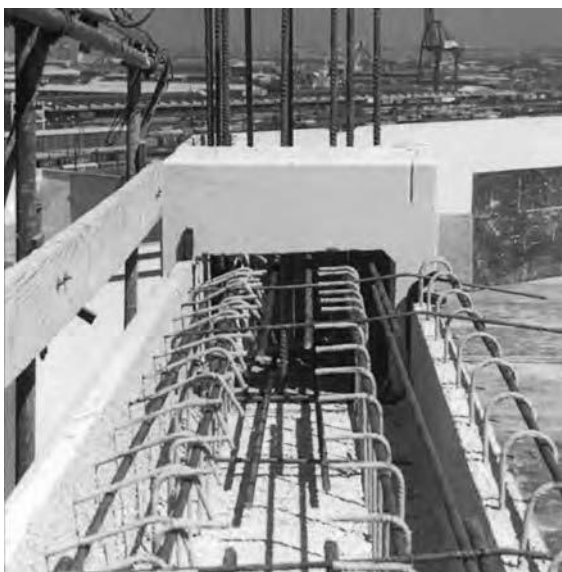

Figure 27.10 – Precast Permanent Formwork used for an Edge beam of a Multi-storey Building

Precast concrete and glass reinforced concrete (GRC) are commonly used for permanent formwork – the former being used where the form takes part of the structural loads and the latter where decorative finishes only are required. The use of permanent forms minimises subsequent finishing operations and often reduces the scaffolding and falsework required for these operations.

6. DESIGN OF FORMWORK

6.1 GENERAL

The design of formwork, particularly on large projects, calls for a considerable degree of skill and experience. Not only can the loads on it be both large and complex, but stripping procedures, and the way they cause loads to be transferred to the concrete structure, are of considerable complexity and importance.

Whilst the actual design should always be undertaken by a specialist formwork designer, all involved with either the erection or removal of formwork on the construction site should be aware of the factors which affect its performance, and in particular its strength and stability – and hence its safety. AS 3610.1 sets out requirements for the design and construction of formwork which are aimed at ensuring its effectiveness and safety.

6.2 LOADS ON FORMWORK

Formwork should be designed to support both the vertical and horizontal loads which are imposed on it whilst it is being erected and while it is in position. In supporting these loads, the formwork should not deflect excessively, buckle, bulge or otherwise move out of position.

The most severe loading generally occurs when the concrete is being placed. However, this is not always the case, so it is common to consider the loads on formwork at three stages of construction:

During Erection – Loads on formwork during erection can arise from two principal sources, (a) the weight of material, equipment etc. which may be stacked on it prior to concreting; and (b)

the effect of wind which may exert both vertical and horizontal forces on the formwork and its supports. Care should therefore be taken to avoid excessive load concentrations and to ensure that bracing is installed as early as possible, and certainly before the formwork is used as a working platform (**Figure 27.11**).

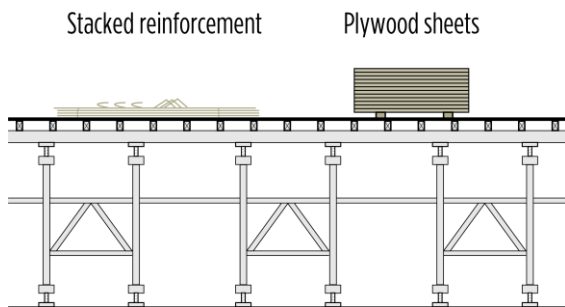
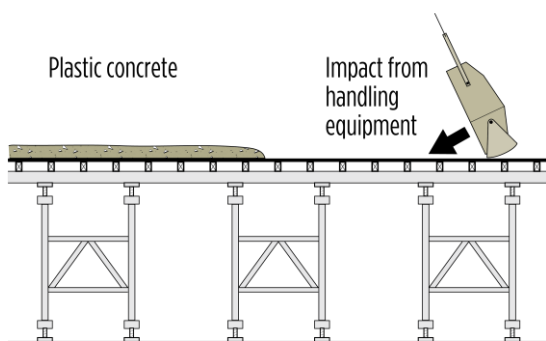

Figure 27.11 – Loads on Formwork prior to Construction

During Concreting – During concreting, the concrete itself imposes a considerable dead weight on the forms. In addition, the weight of men and equipment on the platform should be taken into account. At this stage, lateral stability should also be considered. The formwork with its load of plastic concrete is inevitably top-heavy and therefore particularly susceptible to sideways movement. The possibility of impact arising from a wayward concrete bucket or similar mishap should also be considered (**Figure 27.12**).



NOTE: Lack of continuous bracing

Figure 27.12 – Loads on Formwork during Construction

After Concreting – On multi-storey projects, it is usual for work to proceed on upper floors while the concrete structure below is still gaining strength. Consideration should therefore be given to these additional loads being imposed

on the formwork, and particularly on the props supporting lower floors (see 7.3).

Of prime importance, however, is the lateral pressure exerted on side forms during and after concrete compaction. Vibration liquefies the concrete and increases the pressure exerted on the forms (**Figure 27.13**). Due allowance should be made for this, particularly with deep pours, such as columns.

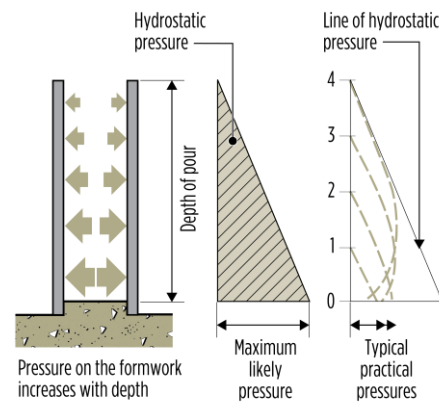

Vibration, which liquefies the concrete, INCREASES lateral pressure on the formwork. Stiffening of the lower layers of concrete, DECREASES lateral pressure on the formwork.

Figure 27.13 - Lateral Pressures on Formwork during Compaction

The lateral pressure exerted by fluid concrete during compaction is by far the most severe loading experienced by vertical forms. Problems such as form liners bulging and deflecting between supports frequently arise because the magnitude of the lateral pressure is underestimated. This is particularly the case with deep narrow forms, where it is often assumed the loads will be less than in (say) heavy columns. In fact, the width of formwork has little influence on lateral pressure, with the principal consideration being the height of the fluid concrete. Factors influencing lateral pressure are set out in **Table 27.3**.

In general terms, any factor which increases the fluidity of the concrete, or the height of fluid concrete, increases the lateral pressure on the formwork (see also comments about flowing concrete in sub-section 3.2). Conversely, any factor which reduces these, reduces lateral pressure (**Figure 27.13** and **Table 27.3**).

Table 27.3 – Formwork Materials

Factor	Effect on lateral pressure
Increasing concrete density	Increases
Increased rates of placing	Increases
Increased heights of pour	Increases
Internal vibration	Increases
Increased slump	Increases
Increased fluidity, e.g. flowing concrete	Increases
Increased concrete temperatures	Decreases
Faster setting cements (including use of accelerators)	Decreases

7. FALSEWORK

7.1 DESIGN OF SUPPORT STRUCTURES

All propping, bracing and fixing elements (collectively the ‘falsework’) that support the formwork and transmit load to the supporting foundation (usually the ground) – should be considered as part of the total formwork system.

NOTE: The term ‘shoring’ used below refers to the process of temporarily supporting a building or structure with ‘shores’ or props to prevent the structure from collapsing during construction or renovation.

Falsework must also be able to resist any tendency to overturn, i.e. the formwork system must be kept stable during erection and concrete placement. Assessments of falsework failures during construction show that the majority of failures occur during concrete placement. These failures can be a result of designers not properly estimating the loads (both live and dead loads) that the falsework structure must support – including additional loads and vibration effects that are experienced

during the placing activities. Problems during reshoring operations and premature falsework or formwork removal have also been significant causes of structural failures.

All support systems should be adequately braced to ensure stability and prevent progressive collapse. Bracing should be provided in two directions at right angles to each other and be provided near the edges of the system where concrete placement is likely to commence. All bracing should be between 30° and 60° to the horizontal.

Design of falsework systems should also take account of the final support conditions (e.g. the ground) and detail the size of base plates/spreader beams needed to take the loads without sustaining excessive deflections.

In multi-storey construction, the propping should extend down a sufficient number of floors to ensure the loads are supported without excessive stress on, or deflection of, the recently cast structure. This design should take account of the rate of concrete strength gain with age and the effect that local environmental conditions may have on it (e.g. concrete gains strength more slowly in cold weather).

The design of support structures should also consider the method to be used for stripping the formwork. It is normal practice to strip soffit formwork in two stages – (1) the sheet/form-face elements which are to be re-used quickly, and (2) the support structure which is to remain in place until the concrete can carry the loads.

7.2 UNDISTURBED SHORES

Proprietary systems are available that enable the support structure to remain in place while the form-face materials are removed for re-use.

In these systems the props (or shores) extend from the base to the soffit of the concrete slab and the deck system is removed around them. This is a preferred system, as the props remain untouched until removal at an appropriate later date. Thus, the risk of deflection and stress changes in the concrete slab during reshoring is eliminated. It also ensures that the props for successive storeys remain in vertical alignment and there is no chance of props being

overtightened, causing reverse stresses in the concrete slab.

7.3 RESHORING SYSTEMS

Reshoring systems involve the removal of a section of the formwork and support structure, following which the support structure is then replaced once the formwork is clear. With proper control and good supervision these systems can give acceptable results. Props must be replaced in the original pattern and not overtightened to avoid causing undesirable stresses in the concrete.

The three usual methods of reshoring are:

- Secondary reshoring – in which shores are placed before any formwork or props are moved. They are placed under the soffit form as close as possible to the original props. The original props and forms are then removed, taking care to mark the location of the original elements – as the final step is to replace the original props and remove the secondary props;
- Partial reshoring – in which the soffit is stripped, bay by bay, and props are replaced on the correct grid and retightened. Typical bays are 2-3 m in width;
- Total reshoring – which involves complete stripping of the soffit and subsequent replacement of the props. This is the least desirable method as it can impose severe stresses on the relatively immature concrete and give rise to excessive deflections.

8. CONSTRUCTION OF FORMWORK

8.1 ERECTION

On many projects the formwork is supplied and erected by a specialist subcontractor. While this has many advantages, it can also cause some problems if there is not good communication between the project designer, the main contractor and the formwork contractor.

Specific matters to which attention should be given include:

- Limitations on the stacking of materials on either partially completed formwork, completed formwork, or on freshly placed concrete. These loads can be substantial and, unless controlled, can lead to overloading of partially completed structures;
- Limitations on the bracing of formwork against concrete elements of the permanent structure. Depending on the age of such elements they may not be able to support such loading without damage;
- Protection of surface finishes on existing work;
- Safety – The maintenance of a safe working environment is the responsibility of all involved with the project. Attention may therefore need to be given to such matters as (a) the provision of access ladders, guardrails and working platforms; (b) safe-load areas and overhead protection for those working below; and (c) suitable lighting and similar facilities.

8.2 PREPARATION FOR CONCRETING

Cleanliness – Once the formwork is erected and set in the correct position, all enclosed areas and surfaces should be cleaned of all foreign debris that may affect the finished surface, including timber, reinforcing steel, tie wires, sawdust, sand, mortar etc. This may necessitate a 'window' at the base of the form through which such material can be discarded.

Where form faces will be inaccessible after erection (e.g. wall forms) release agents should be applied to them before they are erected.

Immediately formwork has been stripped, it should be cleaned without damaging the form face. If necessary, any repairs should then be made to restore the surface. Formwork should be stored to avoid damage and should be stored/stacked to enable easy retrieval.

Release Agents – Most surfaces require the application of a release agent to allow the formwork to part easily from the concrete after it has hardened – without damage to either

surface. However, there are a few specialist plastic form-liners that may not need a release agent.

Release agents permit easy separation of the formwork from the concrete and help to preserve the formwork. In selecting a release agent for a given project, care should be taken to check that it will not:

- Cause unacceptable discolouration to the concrete surface; and/or
- Leave any material on the concrete surface which will prevent bonding of subsequent coatings (e.g. Render, paint).

In the case of wall and column forms, release agents should be applied to clean formwork before it is erected. In the case of soffit forms, release agents are applied before the reinforcing steel is placed (**Figure 27.14**). The release agent(s) can be applied by spray, brush, roller, squeegee etc., depending on its characteristics, but on no account should it be allowed to coat reinforcing steel or any construction joint.



Figure 27.14 – Release Agent being applied to Soffit Form before Reinforcement is placed

Inspection – Formwork must be set accurately in plan and be capable of maintaining the correct line, level, plumb, shape and tolerance during concreting and until the hardened concrete can take the required loads. This requires a detailed inspection procedure to ensure that all elements of the formwork are adequate, clean, in the correct place and wedged/bolted tight.

Before the formwork is assembled it is necessary to check that:

- The forms are clean;
- Repairs have been completed;
- The correct release agent has been used and properly applied to vertical forms; and
- Joints have been sealed.

Before concreting commences it is important to check that:

- The line, level and plumb are correct;
- Dimensions are correct;
- All ties are at correct centres and tight;
- Props and supports are in the correct locations;
- All bracing systems are in place;
- All wedges are nailed;
- All clamps are tight;
- All bolts, jacks etc are tight;
- The supports are founded on a solid base;
- All foreign material has been removed from forms;
- Release agent has been correctly applied to soffits; and
- Joints are sealed and cramped/wedged tight.

During concreting checking is required for:

- Line, level, and plumb maintenance;
- Any settlement;
- Any leakage; and
- Any loosening of wedges, bolts, nails.

8.3 EXTERNAL VIBRATION

In some circumstances, external vibration may be applied to formwork – e.g. in some precast operations, or when placing concrete in thin sections. In these situations, both the formwork and the concrete are vibrated. Where external vibration is used, it is important that (a) the concrete is placed in controlled lifts so that when vibrated, the air can be expelled from the concrete, and (b) the formwork be very rigid and leak free. The formwork designer must be aware of the need to use external vibration when doing the design. External vibration can be used to obtain high quality off-form finishes and also when low slump concrete is being placed.

Vibrating tables constitute a form of 'external vibration'. In these situations, the formwork is attached to the vibrator (and not the vibrator to the formwork as above). The use of vibrating tables is common in the manufacture of concrete products (e.g. concrete blocks) and in precast operations and is used to obtain a consistent level of compaction.

8.4 STRIPPING FORMWORK

General – The project designer is normally required to provide a schedule of stripping times for formwork which is in accord with the requirements of AS 3600. Reference is also made in AS 3600 to the requirements for stripping detailed in AS 3610, and it notes that where stripping requirements in AS 3600 are more stringent than in AS 3610, then the AS 3600 requirements will prevail. The nominated times are minimum stripping times designed to ensure that the structure remains secure from collapse (under its own weight plus that from any additional super-imposed loads) and from damage which might affect its later performance (e.g. cracking or deformation in excess of that anticipated by the designer). Stripping must be carried out in a planned and controlled manner to ensure the proper and controlled transfer of loads from the formwork/falsework to the permanent or existing structure.

AS 3610.1 also provides guidance on stripping times, which, while compatible with AS 3600, refines the requirements to take account of the specified class of surface finish (**Table 27.4**).

The stripping times for formwork removal noted in AS 3600 and shown in **Table 27.4** shall be increased where $L_s/D > 280/\sqrt{(D + 100)}$ (where L_s is the span between formwork supports and D is the overall depth of the member); and the superimposed construction load is >2.0 kPa.

Subject to these general provisions, stripping of formwork should be done at the earliest time – provided that the concrete has developed sufficient strength to prevent damage to the surface of the element. For vertical surfaces, if formwork is stripped less than 18 hours after casting then special care needs to be taken to ensure the surface is not damaged. Where it is

desired to leave vertical formwork in place, either to assist in curing the concrete, or because it suits the construction sequence to do so, it is desirable to ease the forms from the concrete surface as soon as possible to minimise colour variations.

Multi-storey Construction – While the Standards provide some guidance on the minimum stripping times required for multistorey construction, they also point out that the construction and stripping of formwork systems which involve reshoring should be in accordance with the project and formwork documentation. Consequently, it is incumbent on the project designer to provide this information. Reshoring is a hazardous operation which, unless carried out in a correct and systematic manner, can lead to unacceptable loads being placed on the concrete at an early age.

This is particularly so for prestressed concrete as the stressing operations can cause quite substantial loads to be transferred to the shores, re-shores, back-props and other temporary supports.

The advice of the project designer should therefore always be sought for both reinforced and prestressed concrete construction before specified procedures are changed in any way. If specific procedures are not provided in the project documentation, they should be sought.

9. FORMWORK DOCUMENTATION

AS 3610.1 contains a number of requirements in relation to documentation including (a) documentation requirements will vary depending on the complexity of the project, (b) it is expected that all aspects of the formwork design, fabrication, stripping etc. will be included in the documentation which is to be prepared by 'competent persons' (as defined in section 1.5.1.5 of AS 3610.1), and (c) where elements of the design are done by different persons, or where proprietary information is included, all elements need to be collected and collated into a single comprehensive document that fully describes formwork requirements.

Table 27.4 – Minimum Formwork Stripping Times – In-situ Concrete (from AS 3600 and AS 3610.1)

Formed surface	Surface finish classification	Hot conditions > 20°C	Average conditions 20°C ≥ x > 12°C	Cold conditions 12°C ≥ x > 5°C
Vertical faces	Classes 1, 2, 3*	1 day	2 days	3 days
	Classes 4, 5	9 hours	12 hours	18 hours
<i>A minimum of one day applies to the stripping of vertical faces where frost damage is likely.</i>				
Beam and slab soffits elements – reinforced slabs of Normal Class concrete	Formwork removal of beams and slab soffits must be in accordance with AS 3600 section 17.6.2.3 and 17.6.2.4 (and not less than 3 days) as well as conforming to AS 3610.1 Appendix C3.			

NOTE: *Where colour control on surface finishes has been specified it is advisable to strip forms early, subject to the limitations given.

10. SUMMARY – CONSTRUCTION CHECKLIST

- **Loads**
 - What are the stacked load limits at all stages?
 - Are the stacked materials on spreaders?
 - Will the loads be exceeded by any construction procedure?
 - **Materials**
 - Are the correct form materials being used?
 - Is the form face appropriate for the finish required?
 - **Position**
 - Are the forms in the correct location?
 - Are they to dimension and within tolerance?
 - Are they accurate to line, level and plumb?
 - **Fixing**
 - Is the nailing/screwing adequate?
 - Are the ties the correct type?
 - Are they on the correct grid?
 - Are all ties, clamps and bolts tight?
 - Are wedges tight and nailed?
 - **Bracing/Props**
 - Are the props plumb?
 - Are all loads centrally placed?
 - Are supported elements wedged and nailed?
 - Are props straight?
 - Are base plates on adequate foundations?
 - Is the bracing correct?
 - Is the bracing firmly connected?
 - **Cleanliness**
 - Are the form faces cleaned?
 - Is any damage correctly repaired?
 - Is the correct release agent in use?
 - Is it being correctly applied?
 - Has all debris been removed from within the form?
 - **Watertightness**
 - Are all joints properly sealed and cramped?
 - Are the construction joints sealed?
 - **Reinforcing Steel/Inserts**
 - Is the reinforcement correct?
 - Are all inserts/blockouts in the correct location?
 - **Concrete/Concreting**
 - Is the mix design in accordance with the specification?
 - What is the maximum rate of placement permitted?
 - Are the forms maintaining line, level, plumb, shape etc. during concreting?
 - **Stripping**
 - What are the minimum stripping times?
 - Has the project designer permitted modification of these?
 - Do the procedures enable stripping without damage to form or concrete?
 - Are the provisions consistent with the re-use times required?
 - Has the crane the necessary slings etc. to move the forms quickly?
 - What curing methods are to be used once the formwork is removed?
 - Is the storage area for the formwork properly organised?
 - **Safety**
 - Are there adequate guardrails, handrails, walkways, signs etc. in position?
 - **Inspection**
 - Are there enough experienced inspectors on the job to provide appropriate supervision?
-

11. RELEVANT AUSTRALIAN STANDARDS

- 1) AS 3600 – *Concrete structures*
- 2) AS 3610.1 – *Formwork for concrete, Part 1: Specifications*

This Section describes important aspects of the nature, manufacture and use of concrete in relation to associated Occupational Health & Safety (OH&S) issues. Growing emphasis on the rights of workers and the reasonable expectation of being able to go home after a day's work in the same health condition as they arrived has led to a vast improvement in OH&S conditions at work sites and a much improved understanding of the properties of the materials people use during their work day. These good intentions have been supported by improved workplace laws which impose on both workers and employees quite substantial responsibilities for the management of worker and site safety in all workplaces. Employers and employees alike bear the responsibility for keeping workers safe and serious Court-imposed penalties await those who breach their 'duty-of-care'. Genuine OH&S is an issue that, it might be argued, was ignored for a long time. This is no longer the case.

CONTENTS

1. INTRODUCTION	2
2. CONCRETE INDUSTRY OH&S ISSUES	2
3. MATERIALS ISSUES	3
3.1 SAFETY DATA SHEETS (SDS).....	3
3.2 CONCRETE RAW MATERIALS.....	3
4. CONCRETE PLANTS.....	4
5. TRANSPORTING CONCRETE.....	4
6. SITE ISSUES	5
7. SUMMARY	6
8. SUPPORTING DOCUMENTS (AT CCAA.COM.AU)	7
9. REFERENCES	7

1. INTRODUCTION

As an important element of the construction industry, the concrete industry needs to have a high level of awareness of OH&S issues that apply in the industry and must have all industry players contributing to improved understanding and more rigorous processes to ensure worker safety.

Both Federal and State laws cover OH&S requirements and the growing tendency for litigation means that all players – employers, unions and workers – must have awareness of their rights and responsibilities in relation to OH&S. These rights and responsibilities are underpinned by a basic requirement known as a 'Duty-of-Care'.

Duty-of-Care:

- Is a legal obligation on an individual;
- Requires adherence to a reasonable standard of care when performing acts that might cause harm to others;
- Includes carrying out acts or omitting to carry out acts that may result in injury or harm;
- Requires the level of care provided to be commensurate with the potential risk.

It might be asked whether every worker and every employer need to be aware of their legal obligations in relation to all applicable Federal and State laws. That would not be a 'reasonable' expectation. However, employers might be reasonably expected to have prepared policies and procedures (that recognise the legal requirements) for their business, and that workers might reasonably be expected to have read those policies and procedures and to be following them.

The reality is that the cost of OH&S incidents is huge. There are financial costs to businesses, emotional and financial costs to those injured and to their families, and costs to the community more generally from having to supplement the income of families of the injured (or killed). There are no winners from poor OH&S practices – only losers.

2. CONCRETE INDUSTRY OH&S ISSUES

The concrete industry is one that handles high volumes of corrosive products that are produced in mechanised plants, and then transports these large volumes over public roads and onto job sites where they are

subjected to a variety of manual processes. OH&S risks exist at all stages of the concrete 'journey' and these need to be examined separately. The areas that will be examined are:

- Materials issues;
- Concrete plants;
- Transporting concrete;
- Site issues.

3. MATERIALS ISSUES

Concrete is comprised of a number of raw materials – some of which have inherent OH&S risks. The physical and chemical characteristics of plastic concrete create a separate set of risks, and if not treated correctly, hardened concrete can also be hazardous. There are a number of commonalities in the relevant risks. To assist those using hazardous materials to understand the nature of associated OH&S risks requires the creation of a Safety Data Sheet and for this document to be made available to workers.

3.1 SAFETY DATA SHEETS (SDS)

It is a legal requirement that workplaces have SDS for all hazardous chemicals used in that workplace.

NOTE: *Non-hazardous chemicals do not require SDS.*

SDS for all relevant site chemicals should also be compiled and made available in marked locations for workers to access. Workers also need to be aware of safety issues for all chemicals that they use when carrying out their duties.

SDS are required to be prepared in a specific format containing 16 sections as described by Safe Work Australia. SDS must be reviewed at least every five years and each SDS must contain a review date. The information contained within SDS includes naming the chemical(s) and describing any associated hazards; describing the physical and chemical properties of the chemical(s); defining first aid and firefighting measures; providing toxicological and ecological information; noting

transport limitations (e.g. if there is a Dangerous Goods classification) and defining disposal requirements.

SDS must also provide full contact details for the manufacturer and contact details where medical advice about treatment protocols can be obtained in the event of an emergency (e.g. contact details for a Poisons Information Centre).

3.2 CONCRETE RAW MATERIALS

Typically, concrete is composed of cement + SCM's + aggregates + water + admixtures. Within this group of raw materials, the cement and SCM's pose the highest OH&S risks. 'Portland' cement is a fine powder composed of a set of highly alkaline minerals. If the dry cement powder comes into contact with water or (moist) mucous membranes it releases strong alkalinity that will damage the mucous membranes in the mouth, eyes and nose and with persistent contact, can damage normal skin.

If plastic concrete comes into contact with mucous membranes it can cause serious ulceration, and if the eyes are affected, then eyesight can be lost. Persistent contact of cement containing moisture or plastic mortar or concrete with the skin can result in rashes and potentially lead to the development of dermatitis.

NOTE: *Some alkali-activated or other alternative binders may have even higher levels of alkalinity than 'Portland' cement and potentially pose a higher risk of damage to skin and mucous membranes.*

Cement and the SCM's are fine powders with up to 50% of their mass being 'respirable' – i.e. <10 µm in diameter. For some SCM's (e.g. fly ash and silica fume) there may also be a small proportion of crystalline silica in the materials which increases the risks from breathing the fine dusts. Reduction and removal of risk should be carried out by mechanical means (e.g. dust extraction systems) where needed rather than relying on PPE (Personal Protective Equipment) (e.g. dust masks) for worker protection. There is growing awareness of the effects of prolonged exposure to fine siliceous dusts and action needs to be taken to

(a) limit exposure to levels required to meet statutory requirements and (b) protect the health of workers.

Concrete aggregates, both coarse and fine aggregates, pose risks related to dust generation during production, transport and storage at concrete plants. These dusts can contain fine siliceous material which can fall into the categories of either (a) 'nuisance' dust (which may cause minor respiratory distress), and/or (b) respirable dust which can have greater consequences as previously noted. Using water to manage dusty aggregates is the most common approach.

Admixtures are generally quite benign but Safety Instructions in admixture SDS should be understood and adhered to.

4. CONCRETE PLANTS

Concrete plants are multi-faceted operations. They (a) contain storage facilities for cementitious materials and aggregates, (b) facilitate concrete production via either dry batching or wet batching processes and (c) have considerable and continuous vehicle movement occurring within their boundaries. All these activities create OH&S risks in one form or another. Section 9 of this Guide provides more detail about the nature and extent of these activities.

As with any manufacturing operation, the primary means of controlling OH&S risks include (a) having clearly documented procedures for all activities, and (b) a high level of training of plant staff. In addition to these fundamentals, mechanical systems for guarding of moving systems (e.g. guards and trip switches on conveyors and bucket elevators); warning systems to alert staff of plant operational status (e.g. silo-full alarms); traffic management plans; and use of properly qualified technicians (e.g. electricians) are critical to achieving a 'safe site'. A site safety committee should be in place and meet regularly to review plant operational activities and any resultant OH&S issues. Tool-box talks should be used to keep staff apprised of any operational changes and any other issues that might affect their safety.

The use of mechanical devices for lifting should be in place where needed, and attention to the risk of 'falls from height' are two additional and relevant OH&S concerns in concrete manufacturing operations.

Wearing of PPE should be mandated and managed closely for plant staff and visitors.

Visitor entry to the site needs to be formalised and well managed. Visitors should 'sign-in' and 'sign-out' of the site, and no visitors should move around the site unless accompanied by a member of the plant staff.

Housekeeping, which is often a good indicator of overall approaches to site safety, should be actively assessed and managed.

Traffic management – for both vehicles and foot-traffic – should occur only in designated and marked areas. Site speed limits should be signed and rigorously enforced. To control the amount of traffic movement on site it may be appropriate to, where possible, have raw material deliveries made outside concrete production 'peak-periods'.

5. TRANSPORTING CONCRETE

Plastic concrete is a perishable product and must be transported to the job site with some haste to (a) meet requirements of Standards and specifications that limit the time between mixing and placement, and (b) allow placers sufficient time to place and finish the concrete.

While other options do exist, by far the most common method of transporting plastic concrete is by 'agitator' or 'transit mixer' – these being a common sight on our roads today. Concrete trucks carry a heavy and mobile load – mobile in the sense that the plastic concrete is being continually mixed in the revolving barrel, with this movement having the potential to impact on the stability of the truck as it drives along the road, and particularly as it turns around corners or roundabouts.

The risks related to transporting concrete in this manner have led to the industry developing specific Agitator Roll-Over Prevention training in which drivers are educated about the risks

associated with driving concrete trucks and techniques for preventing accidents (see ccaa.com.au/training).

As well as preventing accidents, it is important that transporting concrete on public roads does not result in spillage from the back of the barrel which may create hazards for other road users.

6. SITE ISSUES

From a concrete industry perspective, there are a number of areas of potential OH&S risk at any job site where concrete is being delivered and placed.

At any job site – whether a major inner-city project or a domestic house slab – there is the need for proper management of concrete truck movements. For an inner-city job this may mean proper traffic management at points of ingress and egress at the site using trained traffic management personnel. For a domestic house slab this may mean proper management of the placement of concrete trucks and pumps to allow local traffic to move around the job in an efficient and safe manner.

In addition, the stability of any site is critical if the very heavy concrete trucks are to safely move through or around the site without becoming bogged or tipping. Spotters and other site safety people play a role in managing the safety of the truck at the point of delivery. If a truck has to back up to a pump to unload this process needs to be managed from outside the truck by site safety people or other trained personnel.

Unloading at a pump creates its own issues, particularly if more than one truck at a time is involved. A minimum clearance distance of 600 mm is required between two trucks at a pump, and a spotter should be used to guide the truck movements. Sufficient space for testers to safely carry out their work is also required at the unloading point.

Concrete pumps create their own set of risks. These high pressure, high volume devices need to be the appropriate device for the job and should be well maintained and operated by trained and capable people. As well as ensuring the timely delivery of the concrete to

the job the pump operators also play an important role in ensuring site safety. Pump lines need to be properly primed and cleaned and line connectors need to be appropriate and well fitted and maintained.

As previously noted, plastic concrete is a corrosive, fluid material. Plastic concrete (and in these days that may mean a highly workable, flowing material) should not come into contact with bare skin or other parts of the body (particularly the eyes/nose/mouth), and if it does then appropriate action needs to be quickly taken to thoroughly remove it. Any delay in removing plastic concrete from the eyes may have severe, irreversible consequences. If such an event occurs, immediate first aid is required, followed by a formal medical assessment.

For hardened concrete, a primary concern is the generation of fine dust if the material is sawn or crushed in a way that generates dust. The fine dust will contain a proportion of crystalline silica and it is imperative that no prolonged exposure to such dust occurs.

There are a number of general site-related issues that should be managed to ensure the safety of site personnel during concrete construction, including:

- **Access to forms** – Properly guarded walkways should be provided around formed areas of suspended work so that other trades will have safe access to them before concreting commences, and a safe means of retreat once concreting progresses;
- **Clear areas** – When heavy loads (e.g. formwork, reinforcement, kibbles) are being hoisted by crane, the path over which the load travels should be kept clear of people. Adequate warning for people working in the area should be given before loads are lifted. Clear areas should also be maintained around the anchorages of prestressing tendons while stressing is in progress in case an anchorage failure occurs (also see Part I);
- **Loose objects** – Unfixed materials and hand tools should be kept well away from unguarded edges of suspended

formwork or openings through it or kept entirely within the forms to prevent them falling on people below;

- **Projecting reinforcement** – The cut ends of starter bars which project from construction joints in columns, walls and slabs can be a source of serious injury. As described in Part V, Section 11, (3 – ‘Fixing Steel Reinforcement’) of this Guide, there is a large amount of physical work involved in properly locating and fixing reinforcement on project sites and it is important that related safety issues be understood and any risks removed. One simple solution is the use of proprietary plastic caps (or other simple forms of protector) that can be used to protect workers from unintended contact with projecting reinforcing steel bars;
- **Prestressed concrete** – very high forces are used in both forms of prestressed concrete manufacture. A comprehensive review of the issues and methods used to manage safety concerns in these activities are discussed in Part V, Section 11 (6.6 – ‘Safety’ and 7 – ‘Addendum: Safety Precautions for Prestressing Operations’) of this Guide;
- **Electrical wiring** – Safe practices for temporary electrical installations are set out in AS 3012 and should be followed. Proper safeguards are most important where overhead powerlines cross or are close to work areas, and particularly where cranes are being used;
- **Use of PPE** – The wearing of appropriate PPE is mandated on all sites and subject to ongoing scrutiny by safety personnel and site management. Hi-visibility clothing, steel capped boots and safety helmets are the most fundamental PPE components. Other important parts of PPE kit include work gloves, safety goggles, earmuffs, face masks for dusty environments and sun protection. Two areas of poor practice over many years have been in relation to (a) sun protection and (b) hearing protection. In both cases, impacts on worker health may not be immediately apparent and

the effects in both cases are cumulative and severe;

- **Manual handling** – Modern building sites are far better equipped in relation to handling of heavy loads than once was the case. A common problem of high consequence is that of damage to the spine from workers lifting heavy loads – an issue so severe that in some cases it can prevent workers being able to undertake any type of ongoing employment at all. Wherever possible, mechanical devices should be used to lift or move heavy loads and as a minimum, multi-person lifts should be used to move heavy equipment.

7. SUMMARY

In industry in general, OH&S is an area that has come under strong focus for employers and employees alike over the last few decades. Unsafe activities and systems that were once tolerated or accepted on job sites are no longer considered to be acceptable. Laws relating to OH&S have been updated and upgraded in recent years and these laws impose strict requirements on employers and employees to ensure improved OH&S outcomes at all workplaces. Heavy fines and even gaol are likely consequences for those flouting OH&S laws.

The concrete industry is not immune from these changes and, given the quite high risks associated with a number of elements of concrete production and use, this is appropriate.

Concrete raw materials, concrete production, transport of concrete and the ultimate use of concrete on the job site all come with some level of OH&S risk. This Section has outlined the important risks associated with each part of the concrete ‘journey’.

8. SUPPORTING DOCUMENTS (AT CCAA.COM.AU)

- 1) *'Workplace health and safety guideline – Management of respirable crystalline silica in quarries'* (January 9, 2020)
- 2) *'Guideline for end tipper unloading exclusion zones'* (August 16, 2019)
- 3) *'Concrete pump delivery guidelines'* (May 6, 2019)
- 4) *'Safe Site Delivery Checklist'* (May 3, 2019)
- 5) *'Guideline for pedestrian and traffic management at concrete plants'* (November 22, 2018)
- 6) *'Guidelines for delivery of bulk cementitious products to premixed concrete plants'* (May 28, 2018)
- 7) *'Safety – it's no accident'* (July 21, 2009)
- 8) *'Working safely with wet concrete'* (July 1, 2004)

9. REFERENCES

- 1) Safe Work Australia – <https://www.safeworkaustralia.gov.au/>

GUIDE TO CONCRETE CONSTRUCTION

T41



CEMENT CONCRETE
& AGGREGATES AUSTRALIA

PART X - Environmental Considerations

This section aims to discuss a range of matters related to ‘environment’ that affect, or are affected by, the cement and concrete industries. Whether it is from a technical perspective or a community perspective, matters related to ‘environment’ are topical in both politics and society in general. Since concrete is the most widely used manufactured material in the world, and the second most consumed product next to water, it has the potential to have a major impact on society and on the environment. This section will attempt to consider the wide range of issues that are involved.

CONTENTS

1. INTRODUCTION	2
2. GLOBAL ISSUES	2
2.1 CONCRETE USE	2
2.2 CEMENT MANUFACTURE.....	3
3. LOCAL ISSUES	4
3.1 CONCRETE PLANTS	4
3.2 RESOURCE USE	4
3.3 USE OF INDUSTRIAL WASTES.....	5
4. CONCRETE AS A BUILDING MATERIAL	6
4.1 CONCRETE PROPERTIES	6
4.2 LIFE CYCLE ASSESSMENT	6
4.3 GREEN STAR	7
4.4 LEED RATING SYSTEM.....	7
4.5 ENVIRONMENTAL PRODUCT DECLARATIONS (EPD's)	8
5. SUMMARY – CONCRETE AND THE ENVIRONMENT	8

1. INTRODUCTION

Given the global scale of cement and concrete manufacture and use, environmental factors relating to these materials need to be considered at several levels. With about 33 billion tonnes of concrete being produced per annum across the globe, supported by more than 4 billion tonnes of cement manufacture, the potential for global environmental impacts exists. However, concrete is also produced and used on a very local scale – with concrete plants in most towns and certainly in most cities – so consideration of concrete’s presence at a local level also needs to be considered.

Whereas once the potential impacts of industrial materials were solely the concern of various levels of Government, through their granting of approvals and licences to build and operate plants, this is no longer the case. ‘Environment’ is a ‘hot issue’ in the community, with community concerns extending from local effects related to noise and dust and traffic movement to awareness of and concern about global issues like climate change and pollution of land and sea. To further complicate matters, all levels of Government seem to be increasingly influenced by these community concerns, whether solidly based or not. This means that ‘industry’ now has to have a strong awareness of the environmental issues that may result from their activities and be seen to be reacting to them in practical and demonstrable ways.

This section will examine both global and local ‘environmental’ issues affecting cement and concrete production and use; as well as provide some information about the responses that are being taken to understand and minimise environmental impacts.

2. GLOBAL ISSUES

2.1 CONCRETE USE

Concrete use globally has risen to a level of about 33 billion tonnes per annum. The recent rise in concrete use has been dramatic – having doubled since about 2000. Concrete as we know it came into being in the mid-1800’s and has become increasingly popular since then. The re-building of cities after World War Two was made faster and more economically effective through the use of concrete, and presently, population growth in countries like China and India is fuelling further rapid growth.

Concrete has many advantages over alternative building materials like steel and timber. Concrete is produced locally, using local materials (except for cement), and employs local labour (both skilled and unskilled) in the task of concrete construction. Relatively speaking, concrete is also 'cheap'.

NOTE: *Poor quality concrete construction is also a problem in unsupervised construction situations and can lead to serious structural failures when its use is abused, particularly in earthquake regions or areas that suffer serious weather events.*

While the performance of concrete structures has many advantages, some environmental concerns arise. The large volumes of concrete consume large volumes of raw materials and water. In some parts of the world, for example, sand has become a scarce resource and its recovery and sale have led to illegal mining and 'sand smuggling' operations with consequent environmental degradation. The requirement for large amounts of aggregate materials can lead to poor operation of quarries in some regions. While quarrying activities are very well managed in Australia, this is not always the case globally.

Overall, concrete has assisted countries to grow and house their populations in much more habitable structures, reducing disease and poverty. The simply huge volumes of concrete use make it a target for environmental concerns despite the positive benefits it brings.

2.2 CEMENT MANUFACTURE

The huge rise in concrete production and use has been made possible by the parallel development of cement production capability worldwide. Cement manufacturing capacity has risen from about 1.5 billion tonnes per annum in 2000 to over 4 billion tonnes per annum now. Cement manufacture is a capital and energy-intensive activity that creates considerable concern over the emission levels of CO₂ – a Greenhouse Gas (GHG) – which is believed to be responsible for global climate warming.

In a modern cement plant, the CO₂ emission intensity is about 0.82 tonnes of CO₂ per tonne of cement produced. About 60% of the CO₂

comes from the calcination of limestone, while the remaining 40% comes from the burning of fossil fuels to heat cement kilns and for electricity production used to power the cement plants, including cement milling. The about-60% proportion is an inescapable component due to the chemistry involved. Improved plant efficiencies can reduce the 40%, though the level of improvement has reached close to its limits in recent decades.

From a global perspective, the cement industry is considered to produce about 7-8% of anthropogenic CO₂. If the global cement industry was a country, it would be about the third-largest emitter of CO₂. While at 7-8% the cement industry is well behind industry sectors like transport and energy production in terms of CO₂ emissions, it still comes under considerable scrutiny.

Recognition of the concerns about CO₂ has led the industry to improve its processes over the last few decades, including its expanded use of supplementary cementitious materials like fly ash and slag to partially substitute for cement in concrete production. In Australia, this has led to CO₂ levels in overall cementitious materials used in concrete to be reduced by about 30-35% relative to the use of cement only (i.e. from about 0.82 tonnes of CO₂ per tonne of cement to <0.6 tonnes of CO₂ per tonne of cementitious material).

The concerns about GHG emissions have also led to a huge amount of research work being carried out on alternative cements (or alternative binders), and some limited commercialisation of these 'new' concretes. This work and the nature of these materials are discussed in Section 23 of this Guide. In addition, the cement industry is involved in research to determine if 'carbon capture' is a viable process with which to capture and store the CO₂ produced during cement manufacture.

3. LOCAL ISSUES

3.1 CONCRETE PLANTS

From a community perspective, concrete plants provide some insight into the presence of concrete which otherwise, relative to the widespread use of the material, tends to be taken for granted. Plastic concrete is a 'perishable' product, with only a finite time available to move it from the batch plant to the job site. Since much of the concrete construction is located in community areas, it follows that concrete plants need to be located within these areas, or close to them. As urban sprawl continues (in most places) it is only a matter of time before the community and concrete production overlap. Given the 'time imperative', there is no real option to move concrete production further away from development areas, so it has meant that the concrete industry has had to 'lift its game' to win the confidence of the community. Generally, this has been achieved, and the industry has a strong awareness of community needs and expectations, and the need to abide by local Government requirements, particularly related to environmental issues.

NOTE: *There is one area that does create tension and that is truck movement. It is inescapable that transporting concrete to job sites requires truck movements, and this is often at peak hours. Even this aspect of industry/community interaction is being addressed where it can be. Truck movements are also associated with the delivery of raw materials to concrete plants – aggregates and cementitious materials particularly – and in some cases these are carried out at night to minimise truck movements in otherwise busy periods.*

Modern concrete plants are generally well screened from the community, and past concerns like high levels of noise and dust have been addressed quite successfully. Some basic environmental concerns like water run-off and water re-use are also being properly addressed. This work is being done both at plant and industry levels, and the range of Guideline documents prepared for use by concrete producers is testament to the seriousness of the industry in addressing these issues. These guidance documents include:

- CCAA, 'Environmental Management Guideline for Concrete Batch Plants' (October 2019);
- CCAA, 'First Flush and Water Management Systems: Guide and Principles' (August 2013);
- CCAA, 'Use of Re-Cycled Water in Concrete Production' (August 2007);
- CCAA, 'Best Practice Guidelines for Concrete By-Product Re-Use at Concrete Batch Plants – Queensland' (June 2012);
- CCAA, 'Guidelines for Delivery of Bulk Cementitious Materials to Premixed Concrete Plants' (March 2018);
- CCAA, 'Guideline for Pedestrian and Traffic Management at Concrete Batch Plants' (November 2018).

There are many examples of concrete producers ensuring that their operations 'fit' within their community and plant siting and operation are often undertaken to ensure that the concrete industry is seen as a good citizen.

3.2 RESOURCE USE

From an economic perspective, it is essential that the large volumes of raw materials, particularly aggregates, are sourced from as close to the concrete plant as possible. This also has environmental benefits through requiring less travel distances for trucks carrying out these deliveries. The concrete industry is supported by large quarrying activities, and these are also a source of community concern. Generally, quarry operations do not gain the attention of the community as these operations are typically well screened, and dust and noise issues (from blasting) are very well managed. From a quarry operation perspective, the main area of contention is when quarries seek to expand their resource and the community becomes aware of this through consultation processes. Often protracted battles are waged to prevent or limit quarry expansion. This has the effect of forcing quarries further away from the areas where their products are used and hence increasing truck movements and costs.

It is truck movements that, once again, make the quarry industry visible. The reality is that in Australia, quarry products are used at the rate of about 8 tonnes per person per year, so large quantities are being moved on our roads. Development of housing, industry and infrastructure as we know it cannot occur without these quarry products.

The various concerns about quarry activities has again resulted in a strong industry response to ensure quarry operators understand the issues and have tools to address them. Some of the guidance documents available to industry include:

- CCAA, '*CCAA Guideline – Assessment and Control of Environmental Noise Emissions from Quarries – Qld.*' (May 2105);
- CCAA, '*Extractive Industry Model Codes Version 1.0 and Guideline for the Extractive Industry Model Codes Version 1.0*' (August 2012);
- CCAA, '*Safety Data Sheets for Products Containing Respirable Crystalline Silica*' (December 2018);
- CCAA, '*Workplace Health and Safety Guideline – Management of Crystalline Silica in Quarries*' (January 2020).

The availability of natural sands is also decreasing, forcing the industry to look further afield for suitable sources, and also to look at alternatives to the natural products. The use of manufactured sands is now a 'norm' in concrete production. Approvals from specifiers for the use of manufactured sand as a partial replacement for natural sands came after a large body of industry research had been carried out to (a) technically describe appropriate properties for manufactured sands, and (b) develop and assess appropriate test methods to assess them. This work is described in a CCAA Research Report '*Manufactured Sands – National test methods and specification values*' (January 2007). The use of manufactured sands not only reduces the pressure on natural sand sources but also increases the efficiency of use of quarry resources.

3.3 USE OF INDUSTRIAL WASTES

For several decades, the concrete industry has been a large recycler through its significant use of 'waste' materials in its products. Fly ash and slag, nominal 'wastes' from coal-fired electricity generation and iron blast furnaces respectively, have been used as partial cement substitutes in Australian concrete. Their use has seen about a 35% reduction in the embodied CO₂ levels in concrete – this CO₂ deriving from cement. As well as directly improving the environmental credential of concrete, the use of these supplementary cementitious materials also improves concrete quality – particularly durability performance and also reduces the volumes of waste materials that would otherwise be landfilled. Fly ash and slag also form the basis of much of the development work on alternative binders as discussed in Section 23 of this Guide.

Recycling of concrete demolition wastes is carried out in Australia, but probably not to the extent that it is in other countries. Market size and transport distances mitigate against the broader re-use of concrete demolition wastes, though the level of re-use is increasing.

Some other recycled materials are being used in concrete and trials are underway to expand that use where possible. Crushed, recycled glass is used to a small extent as a partial sand replacement in concrete. Further test work is required to validate this use. Recycled glass can also be used as a cementitious material if crushed to a high degree of fineness (similar to cement) but this is not economical at this time. Other materials that have been the subject of research and field trials include (a) crumbed rubber (from tyres) as a partial aggregate replacement, (b) recycled plastics converted into plastic fibres for use in reinforcing, (c) sintered fly ash and bio-chars as aggregate replacements and (d) rice husk ash (waste from combustion of rice husks or hulls) for use as a supplementary cementitious material.

4. CONCRETE AS A BUILDING MATERIAL

4.1 CONCRETE PROPERTIES

Concrete has a number of inherent properties that make it an ideal building material, and it compares very favourably with other materials in terms of being strong and resistant to fire and pests; it is durable; it is inert and non-toxic (with no volatile emissions); it has a high thermal mass and good (sound and thermal) insulation properties; it is versatile and has the distinct advantage of being able to be moulded to many shapes and then subsequently harden in that shape; it is re-cyclable; and it is of relatively low cost. These various properties have contributed to the huge and increasing growth in concrete construction worldwide.

While cement manufacturing is capital intensive, concrete production is a low capital cost, simple process that is carried out locally and supports local economies. Properly designed and constructed concrete structures are very strong and very durable and can provide good long-term value to users.

When properly designed, concrete buildings impart environmental benefits as a result of several important characteristics, namely:

1. Concrete can store heat which then later flows into the building as it cools down in the evening resulting in reduced air conditioning loads through creating a more consistent temperature environment;
2. Concrete can act as a thermal insulator;
3. Concrete reduces sound transmission in commercial and residential structures; and
4. If there are concerns about a 'heat island' effect in built-up areas then concrete roofs, roads and footpaths can be made reflective through using light coloured (or white) concrete.

More detailed reviews of concrete properties important for building and construction appear in the following:

- CCAA Briefing 10, '*Building in bushfire-prone areas*' (July 2007);

- CCAA Briefing 12, '*Thermal mass benefit for housing*' (July 2007);
- CCAA Briefing 16, '*Quiet and comfortable concrete homes*' (July 2007);
- CCAA Briefing, '*Handy hints in specifying concrete buildings*' (March 2018).

4.2 LIFE CYCLE ASSESSMENT

There is no doubt that the manufacture of cement is both energy intensive and results in significant CO₂ (GHG) emissions. However, stand-alone this does not imply that cement or concrete use is environmentally unsound. If a structure is required, then it needs to be constructed from one material or another, and in any assessment a comparison is required. Moreover, it is the structure as a whole that should be assessed, not simply one component of it, and for its whole life cycle.

A technique known as Life Cycle Assessment (LCA) can be carried out to assess the energy use and GHG emissions associated with the construction, operation and ultimate demolition of any structure. To make sense of this assessment it should be done on a comparative basis to assess the relative performance of various construction material options.

An independent study carried out to compare various construction material options used in the construction of a domestic dwelling, an office building and a warehouse was carried out. The results showed that:

- There was no significant difference between the material options studied in terms of energy intensity and GHG emissions for the three building types reviewed;
- The energy use associated with the construction and maintenance of the structures was only about 10% of the total energy used during its lifetime, with energy use associated with building operation being by far the greatest component;
- Consideration of any single structural or operational element did not give a

realistic assessment of materials or structure comparisons; and

- LCA gives a balanced assessment of the energy and emissions performance for the entirety of the structure and life cycle including materials, construction and operational activities.

A more comprehensive review of the material properties of concrete and their environmental significance, as well as details of the LCA study, has been reported in the following:

- CCAA, 'Concrete – The responsible choice' (July 2012).

4.3 GREEN STAR

The Green Building Council of Australia has developed a sustainability rating system known as Green Star that allows a sustainability score to be ascribed to a building – though the system is currently limited to office buildings and apartment blocks. Star ratings can range from 1 Star = Minimum Practice to 4 Stars = Best Practice; 5 Stars = Australian Excellence and 6 Stars = World Leadership in sustainable practices in building design, construction and operation. Star ratings are earned through scores derived from a wide range of sustainability initiatives that are included in the building. The total score determines the Star-rating.

From a concrete perspective, there are up to 3 Green Star points available as follows:

- One point – where 'Portland' cement use is reduced by 30% in all concrete used across the project – relative to a reference mix;
- Two points – where 'Portland' cement use is reduced by 40% in all concrete used across the project – relative to a reference mix;
- One point – where at least 50% of the water used in concrete is captured or reclaimed water, plus **either** of at least 40% of coarse aggregate is crushed slag aggregate or other alternative materials (provided this does not increase the Portland cement content of the mix by more than 5 kg/m³), **or** at

least 25% of the fine sand is manufactured sand or other alternative material (provided this does not increase the Portland cement content of the mix by more than 5 kg/m³).

NOTE: A series of reference Portland cement contents are listed in the Green Star documentation for all concrete grades from 20-100 MPa and claimed Portland cement reductions are measured against the nominated cement content in these references mixes.

More detail on the Green Star system and its application are provided in the following references:

- CCAA Industry Guide, 'Green Star – Life Cycle Impacts – Concrete Credit 19B1 User Guide' (August 2017);
- CCAA Industry Guide, 'Green Star Mat-4 Concrete Credit User Guide' (June 2015);
- CCAA Technical Note 70, 'Six-Star Concrete Housing' (April 2013).

While the Green Star system is currently used for offices and apartments, there is a system under development called 'Future Homes' that intends to extend the Green Star system to domestic housing.

4.4 LEED RATING SYSTEM

The LEED system is an American sustainability rating system that has been in place for many years and which is sometimes referred to in Australian projects. The latest version, Version 4, has changed from a system that focussed on single attributes of materials (e.g. recycled content or regional materials) to one that takes a more holistic approach through the use of LCA and product disclosure and optimisation. Product disclosure means reporting environmental, social and health impacts associated with use of materials using third-party assessments, examples being Environmental Product Declarations (EPD) (see 4.5) and Health Product Declarations (HPD). Projects are required to use at least 20 products for which EPD's and/or HPD's exist, and concrete has an advantage here because if concrete is used in slabs, paths,

walls etc., each constitutes a 'product'. Use of locally produced (within 100 miles/ 160 km) products is also encouraged, which again favours concrete. A Construction Waste Management credit that is included is also beneficial provided construction wastes are used for alternative purposes and not landfilled. The system also includes a Global Warming Potential (GWP) assessment which requires, much like the Green Star system, project concrete mix designs to incorporate binder and aggregate components that have a lower GWP than baseline mixes that might otherwise be used.

4.5 ENVIRONMENTAL PRODUCT DECLARATIONS (EPD's)

EPD's are independently verified and registered documents that communicate transparent and comparable information about the life-cycle environmental impacts of products. There is an ISO Standard (ISO 14025) that details the requirements for preparing EPD's. Certified EPD's need to be prepared in accordance with Product Category Rules which describes the scope of the LCA that needs to be carried out and identifies the types of potential impacts that need to be evaluated and reported. The LCA's must be carried out by a neutral third-party. There is no 'global' EPD for concrete and individual companies must develop an EPD for their product(s) as manufactured in their plants and using the suite of materials available to them.

EPD's are useful in achieving accreditation in systems like LEED (as noted above) and will likely become a fundamental part of bidding processes for projects funded, for the time being at least, by large corporations and Government bodies.

5. SUMMARY – CONCRETE AND THE ENVIRONMENT

In the last (almost) 200 years, concrete has become the most popular building and construction material used throughout the entire world. That this is the case is testament to its relative simplicity of manufacture and

use, its design versatility, its strength and its durability. The use of concrete is common in both the developed and under-developed worlds and the recent strong growth in its use is associated largely with the growing wealth of previously poor countries. Concrete is, by volume, the most commonly consumed material in the world after water, with recent production estimates being about 33 billion tonnes per annum. Almost any material used to this extent will bring with it concerns about impacts on the environment. That concrete uses large volumes of natural resources (e.g. aggregates) and contains a proportion of an energy and GHG-intensive product like cement adds to the environmental concerns. It is estimated that the cement industry contributes about 7-8% of the world's man-made CO₂.

In response to concerns about environmental impacts, the cement and concrete industries have made concerted efforts to (a) understand the nature and performance of its products, and (b) to find ways to mitigate any environmental concerns. While much of this work has been very successful and the concrete industry generally works well within its local communities, the concerns about GHG emissions remain and are largely insurmountable with current technologies. Work is underway to develop new cement types that give lower GHG emissions (see Section 23 of this Guide).

The reality for the moment is that concrete use will continue to grow, as will cement manufacture. Despite concerns, concrete is an effective and efficient building material from both engineering and environmental perspectives and its ongoing use reflects this. It remains a challenge for the cement and concrete industries to find a way to ensure that concrete – as we know it or in a modified form – remains the first choice for most future building activities.

GUIDE TO CONCRETE CONSTRUCTION

T41



CEMENT CONCRETE
& AGGREGATES AUSTRALIA

CONTENTS

1. INTRODUCTION.....	4
1.1 USE OF THIS DOCUMENT.....	4
1.2 REFERENCE DOCUMENTS.....	4
2. DEFINITION OF TERMS	5
3. REFERENCE DOCUMENTS	5
4. STANDARD TEST METHODS	6
5. QUALITY SYSTEM REQUIREMENTS	6
5.1 SUBMITTALS, HOLD POINTS, WITNESS POINTS AND MILESTONES	6
5.2 CONSTRUCTION PROCEDURES	7
5.3 CONFORMANCE REQUIREMENTS	7
5.4 TESTING FREQUENCY.....	8
6. CONCRETE CLASS.....	8
6.1 MIX DESIGNATION.....	8
6.2 NORMAL CLASS CONCRETE.....	9
6.3 SPECIAL CLASS CONCRETE.....	9
6.4 SPECIAL CLASS PRECAST AND PRESTRESSED PRECAST CONCRETE.....	9
7. MATERIALS.....	9
7.1 CEMENT	9
7.2 SUPPLEMENTARY CEMENTITIOUS MATERIALS....	10
7.2.1 Fly Ash.....	10
7.2.2 Ground Granulated Blast Furnace Slag.....	10
7.2.3 Amorphous Silica	10
7.2.4 Cementitious Blends	10
7.3 WATER	11
7.4 CHEMICAL ADMIXTURES.....	11
7.5 CONCRETE AGGREGATES.....	11
7.5.1 Coarse Aggregates	12
7.5.2 Fine Aggregates.....	12
7.6 CONCRETE ADDITIVES, COLOURS AND FIBRES.....	12
7.6.1 Solid Mineral Additives.....	12
7.6.2 Colours.....	13
7.6.3 Fibres	13
7.7 CURING COMPOUNDS.....	13
8. STORAGE OF MATERIALS.....	14
8.1 CEMENTITIOUS MATERIALS ...	14
8.2 AGGREGATES.....	14
9. CONCRETE MIX DESIGN AND ACCEPTANCE	14
9.1 SLUMP AND SLUMP SPREAD..	15
9.2 AIR CONTENT COMPLIANCE... ..	15
9.3 COMPRESSIVE STRENGTH COMPLIANCE	16
9.4 TENSILE STRENGTH COMPLIANCE	16
9.5 SPECIFIC EXPOSURE CLASS REQUIREMENTS.....	17
9.6 TESTING FOR CONCRETE DURABILITY.....	18
9.7 CHLORIDE CONTENT TESTING	18
9.8 SULFATE CONTENT TESTING.	19
9.9 DRYING SHRINKAGE TESTING	20
10. BATCHING, MIXING AND TRANSPORT OF CONCRETE	20
10.1 BATCHING	20
10.2 MIXING	21
10.3 TRANSPORT AND DELIVERY ..	21
11. ACCEPTANCE AND REJECTION OF PLASTIC CONCRETE.....	21
12. ACCEPTANCE AND REJECTION OF HARDENED CONCRETE.....	22
13. ENVIRONMENTAL LIMITS FOR CONCRETING OPERATIONS.....	22
13.1 TEMPERATURE LIMITS	22
13.2 ENVIRONMENTAL LIMITS	22
13.2.1 Estimation and Control of Evaporation Rates	22
13.2.2 Application of Evaporation Retarding Compound	23
13.3 PROTECTION FROM RAIN	24
13.4 CURING OF CONCRETE.....	24
14. DEFECTS AND RECTIFICATION .	25
15. NORMAL CLASS CONCRETE FOR IN-SITU, PRECAST AND PRECAST-PRESTRESSED APPLICATIONS .	25

15.1	CONCRETE CLASS	25			
15.2	MATERIALS	25			
15.2.1	Cement	25			
15.2.2	Supplementary Cementitious Materials	25			
15.2.3	Chemical Admixtures	25			
15.2.4	Concrete Aggregates	25			
15.2.5	Alkali Reactive Aggregates	25			
15.2.6	Curing Compounds	25			
15.2.7	Other Methods of Curing Concrete	25			
15.3	STORAGE OF MATERIALS	26			
15.4	CONCRETE MIX DESIGNS	26			
15.5	BATCHING, MIXING AND TRANSPORT	26			
15.6	ACCEPTANCE AND REJECTION OF PLASTIC CONCRETE	26			
15.7	ACCEPTANCE AND REJECTION OF HARDENED CONCRETE	26			
15.8	DEFECTS AND RECTIFICATION	26			
15.9	FALSEWORK	26			
15.10	FORMWORK	26			
15.10.1	Supports (Bar-Chairs and Spacers)	26			
15.11	PLACING AND COMPACTING CONCRETE	26			
15.12	TOLERANCES	27			
15.13	FINISHING OF CONCRETE	27			
15.13.1	Prevention of Cracking	27			
15.13.2	Finish Type	28			
15.14	CURING OF CONCRETE	28			
15.15	EARLY LOADING	28			
15.16	REMOVAL OF FORMWORK	28			
15.17	SURFACE TREATMENT OF CONCRETE	28			
15.17.1	Formed Surfaces Exposed to View	28			
15.18	CONSTRUCTION, ISOLATION, EXPANSION AND CONTRACTION JOINTS	28			
15.18.1	Construction Joints	29			
15.18.2	Isolation and Expansion Joints	29			
			15.18.3	Contraction Joints	29
			16.	SPECIAL CLASS CONCRETE FOR IN-SITU APPLICATIONS	30
			16.1	MIX DESIGNS	30
			16.1.1	Special Mix Schedule	30
			16.1.2	Trial Mixes	30
			16.2	MATERIALS	31
			16.2.1	Special Materials	32
			16.3	TESTING PROCEDURES	32
			16.3.1	Early Stripping	32
			16.3.2	Early Loading	32
			16.4	FALSEWORK	33
			16.5	FORMWORK	33
			16.5.1	Supports (bar-chairs and spacers)	33
			16.6	CONCRETE TEMPERATURE ...	33
			16.7	PLACING AND COMPACTION OF CONCRETE	33
			16.7.1	Placing Under Water	33
			16.8	TOLERANCES	33
			16.9	REMOVAL OF FORMWORK	33
			16.10	SURFACE TREATMENT OF CONCRETE	33
			16.11	FINISHING OF CONCRETE	33
			16.12	CURING OF CONCRETE	33
			16.13	CONSTRUCTION, ISOLATION, EXPANSION AND CONTRACTION JOINTS	33
			16.13.1	Construction Joints in Marine or Other Aggressive Environments	34
			17	SPECIAL CLASS CONCRETE FOR PRECAST AND PRECAST- PRESTRESSED APPLICATIONS .	34
			17.1	MIX DESIGNS	34
			17.1.1	Special Mix Schedule	34
			17.1.2	Trial Mixes	34
			17.2	MATERIALS	34
			17.2.1	Special Materials	34
			17.3	TESTING PROCEDURES	35
			17.4	CONCRETE TEMPERATURE ...	35
			17.5	PLACING AND COMPACTING CONCRETE	35

17.6	DIMENSIONAL TOLERANCES..	36
17.7	REMOVAL OF FORMS OR DEMOULDING	36
17.8	SURFACE TREATMENT OF CONCRETE	36
17.9	CURING OF CONCRETE	36
	17.9.1 Heat Accelerated Curing (HAC)	36
18	REFERENCES	37
18.1	AUSTRALIAN STANDARDS	37
18.2	INTERNATIONAL STANDARDS	37
18.3	GENERAL REFERENCE DOCUMENTS	37

1. INTRODUCTION

1.1 USE OF THIS DOCUMENT

This specification has been developed in good faith and is based on current Standards and industry practices. The use of concrete in structural applications is very broad and the Specification cannot realistically cater for every possible concrete end-use. While every effort has been made to ensure that Specification details are correct and appropriate, there may be certain circumstances where alternative approaches are required. If there is any uncertainty about the applicability of this Specification for any particular project or structure, then additional advice should be sought.

1.2 REFERENCE DOCUMENTS

ASTM defines a specification document as follows:

- An explicit set of requirements to be satisfied by a material, product, system, or service;
- Usually forms part of a contract.

Every project has a unique set of drawings and associated contractual and technical documentation. Similarly, every project needs a unique specification which identifies the project requirements not included on the drawings. Together, the drawings and the specification

describe outcomes that the Contractor is expected to deliver for the project. Specifications can either be written as prescriptive – containing all information required for the project – or provide references to the relevant standards and codes of practice to be applied or apply a combination of the two approaches.

There is a general classification of information used in project construction and delivery that has a hierarchy of importance from a legal perspective. The concrete specification forms part of that documentation. In terms of the hierarchy of documents referenced in a specification, the contained information is classified as follows.

Codes (may be referred to as Regulation)

- Top level document sometimes linked to an Act of Parliament;
- Call up Australian Standards: Primary or Secondary.

Examples include:

- Building Code of Australia;
- National Construction Code.

Standards

- These are published documents that generally provide the minimum acceptable standards of a material quality, design method, test method, construction system or finished product;
- Set out procedures designed to ensure products, services and systems are safe, reliable and consistently perform the way they are intended to;
- Can form part of a contract;
- Development of these documents is complex and there are strict procedures involved with their production and review.

Guides

- Published technical reference;
- Industry or issue specific 'best practice';
- Used to support specifier, contractor or supplier position.

This document provides a framework for the development of project-specific specifications for concrete with a checklist detailed below that

covers the elements that should be included in the development of the specification:

- General requirements;
- Scope of specification;
- Interpretation;
- Referenced Documents including Codes of Practice;
- Australian Standards;
- International Standards where applicable in Australia;
- Technical Guidance Notes;
- Definitions;
- Inspection, testing and submittals;
- Concrete and Concrete Component Material specifications;
- Reinforcing Steel, Fibres and Post-Tensioning;
- Concrete Supply and Delivery;
- Other materials required in the construction of concrete structural elements;
- Execution;
- Formwork as it relates to the finished concrete in place;
- Placing and Fixing Reinforcing Steel;
- Placing and Fixing Post-Tensioning;
- Concrete Pumping, Placement, Compaction, Finishing and Curing;
- Concrete Testing;
- Other requirements that are specific for a particular concrete application;

In addition to the above, the following items may be nominated in the specification if applicable:

- Portland and blended cement type;
- Concrete temperature limitations;
- Requirements for supplementary cementitious materials;
- Type and properties of reinforcing steel;
- Stripping agent requirements;
- Approval of constituent materials;
- Methods for assessment of finished concrete surfaces.

Concrete is utilised in many different structural applications and so this list cannot cover every application. Additional information may be required to meet specifics of a given project. Similarly, a number of items in this document

may not need to be included within a specification if they are not applicable to a specific case. For example, details of post-tensioning would be inappropriate to include for a structure that only utilises conventional reinforcement.

This document may refer to information in other Sections of the Guide. CCAA have also developed technical notes ('Data sheets') that may also be referenced (refer to references list at the end of this document).

The Guide document also contains a '*Glossary*' section that aids the user in providing definition of words or phrases that may be specific to concrete construction and/or have meaning that is not widely understood.

In this document, the relevant elements of a concrete specification are suggested with guidance on what can be included in each section/sub-section. Text included in *italics* is used to demonstrate examples of wording that may be appropriate in the situations defined in the text. Such examples should not be interpreted as being correct or appropriate for all circumstances.

2. DEFINITION OF TERMS

The terms and symbols used in this document will be as defined in the '*Glossary*' section of the Guide to Concrete Construction. It is generally useful to include a glossary or definition of terms in any concrete specification and this can follow a similar, tabular format to that used in the Guide '*Glossary*'.

3. REFERENCE DOCUMENTS

When developing a specification, it is important to define the reference documents and versions used in relation to the specification. These documents can be Codes of Practice, Australian Standards, International Standards, Guides, or possibly other publicly available specifications that are relevant to the construction project (e.g. a Local Government specification).

4. STANDARD TEST METHODS

As there are many ways of testing the same property of concrete there needs to be clarity about the methods that are required to be used. A simple way to do this in a project specification is to tabulate this information as noted in the following example.

*The standard test methods stated in **Table XI.1** shall be used in this Specification.*

Further details of test numbers and test descriptions are given in the following sections of this specification.

All tests for the purposes of compliance including sampling are to be performed and reported by a NATA-accredited laboratory, whose scope of accreditation encompasses the test method used.

5. QUALITY SYSTEM REQUIREMENTS

This section provides a 'roadmap' to the special quality system requirements that relate to the particular project and can include:

- Submittals;
- Hold Points;
- Witness Points;
- Milestones.

It is common practice to highlight these points in the specification document by adding '**HOLD POINT**', '**WITNESS POINT**' or '**MILESTONE**' to the end of a relevant paragraph in the specification document.

These quality system requirements are defined in the following table overleaf.

5.1 SUBMITTALS, HOLD POINTS, WITNESS POINTS AND MILESTONES

Submittals

Submittals are a part of each of Hold Points, Witness Points and Milestones. Submittals include all documentation and records that the contractor, or sub-contractor, must provide to

demonstrate compliance with the Drawings and Specification. These requirements will be dependent on the scope of work.

Hold Points

Hold Points are a mandatory verification point beyond which work cannot progress without approval by the designated authority, typically the Engineer or Consultant or Third-Party Inspector. Some common hold points in concrete construction may include:

- Formwork & Falsework design certification;
- Formwork & Falsework execution certification;
- Formwork & Falsework calculations;
- Re-shoring details;
- Formwork removal documentation;
- Special class concrete mix design approval;
- Approval of concrete placing, compaction, finishing and curing procedures;
- In some cases, verification of special class concrete trial mix test results (such as drying shrinkage, creep testing, various durability tests as well as standard tests called for in AS 1379).

Witness Points

Witness Points are identified points in the process where the designated authority, typically the Engineer or Consultant or Third-Party Inspector may review, witness, inspect the method or process of work. The activities, however, may proceed. Some common witness points in concrete construction may include:

- A trial mix of special class concrete;
- Placing and compaction of concrete;
- Finishing and curing of concrete;
- Possibly repair of hardened concrete.

Milestones

Milestones are tools used in project management to mark specific points along a project timeline. These are generally time-based and relate to the critical path of the construction plan. Some common milestones in concrete construction may include:

- Timing of the submission of proposed

- concrete mix designs;
- Submission of hot or cold weather concrete placing and finishing procedures;
 - Submission of falsework and formwork drawings;
 - Submission of underwater concrete placement procedure;
 - Submission of concrete curing procedure;
 - Submission of heat-accelerated curing procedure.

Table XI.1 – Standard Test Methods

Property to be Tested	Standard Test Method
Alkali-Silica Reactivity	AS 1141.60.1 and AS 1141.60.2
Chloride ion content (water-soluble)	AS 1012.20.2
Crushed particles	AS 1141.18
Flakiness index	AS 1141.15
Light particles	AS 1141.31
Material finer than 2 µm	AS 1141.13
Material finer than 75 µm	AS 1141.12
Particle density and water absorption	AS 1141.5 and AS 1141.6.1
Particle size distribution	AS 1141.11.1
Weak particles	AS 1141.32
Wet Strength	AS 1141.22
Sugar content of Aggregate	AS 1141.35
Wet / Dry Strength Variation	AS 1141.22
Compressive strength	AS 1012.8.1 and AS 1012.9
Slump	AS 1012.3.1
Mass per unit volume	AS 1012.5
Slump Spread	AS 1012.3.5
Visual stability index	ASTM C1611

5.2 CONSTRUCTION PROCEDURES

The contractor will be required to submit their quality procedures and related quality plans to the designated authority. A simple way to do this in a project specification is to tabulate the location of the requirements of these procedures in the project specification as noted in the following example.

The Contractor shall prepare and submit, to the designated authority, documented procedures for construction processes in accordance with the quality system requirements of the Contract. These processes are listed in Table XI.2.

Table XI.2 – Construction Procedures

Procedure	Specification Clause
Batching and mixing of concrete	10
Hot weather concreting	13
Temperature monitoring (large elements and/or high cementitious contents)	16.6
Placement under water	16.7.1
Curing of concrete	16.12
Surface treatment of hardened concrete	15.17, 16.10, 17.8

5.3 CONFORMANCE REQUIREMENTS

The specification will cover a number of requirements for conformance in the project specification. It is useful to locate these in the project specification by tabulating the location of the conformance requirements of concrete, concrete constituents and finished concrete in the project specification as noted in the following example.

The conformance requirements which apply to work covered by this Specification are summarised in Table XI.3.

Table XI.3 – Conformance Requirement

Procedure	Specification Clause
Concrete constituent materials	7, 15.2, 16.2, 17.2
Plastic concrete properties	9.1, 9.2, 11, 15.6
Hardened concrete strength	12, 15.7
Concrete temperature	16.6, 17.4
Dimensions and levels	15.12, 16.8, 17.6
Surface finish of concrete	15.13, 16.11
Surface condition	15.17, 16.10, 17.8
Heat-accelerated concrete	17.9.1

5.4 TESTING FREQUENCY

The concrete specification should detail the minimum testing frequency requirements for concrete and in some cases may require testing frequency of some or all of the concrete constituents. In most cases these frequencies can be guided by the Australian Standards but in some cases of special class concrete used in critical works higher frequencies may be required.

For normal class concrete the testing frequency should be guided by AS 1379 requirements. For all other special class concrete the requirements of AS 1379 may be used but section 12 discusses specifying alternative test frequencies to those in AS 1379.

6. CONCRETE CLASS

This section considers three types of concrete classifications:

- Normal Class concrete as defined in AS 1379;
- Special Class concrete as defined in AS 1379;
- Special Class Precast concrete.

The Special Class Precast concrete is a particular case of Special Class as the curing method and typical mix designs are designed

for higher early strength and warrant particular quality plans to manage them.

6.1 MIX DESIGNATION

The specification should give guidance on the designation of concrete mixes to be used.

When normal class concrete is specified it is required to specify the following when ordering in accordance with AS 1379:

- Concrete strength grade (one of N20, N25, N32, N40 or N50). Higher strength grades are deemed to be special class concrete;
- Concrete target slump (between 20 mm and 120 mm in 10 mm increments);
- Maximum aggregate size (one of 10 mm, 14 mm or 20 mm). Other maximum aggregate sizes are deemed to be special class concrete;
- Method of placement and type of equipment (e.g. Pump, crane and bucket, conveyor etc.);
- Target air content up to 5.0% (if specified for freeze/thaw durability).

There are other properties of concrete that are associated with normal class concrete detailed in AS 1379 that are assumed if normal class concrete is specified.

A common method of designating a normal class concrete is 'Strength grade/Max Aggregate size/Target slump/Placing method'. In the case of a normal class concrete with characteristic strength of 32 MPa, a target slump of 80 mm and maximum aggregate size of 20 mm and concrete to be placed by concrete pump, the designation would be '32/20/80/P'.

In many cases the specifier will leave it up to the construction contractor to specify the concrete slump and placing method and in this situation the specification may remain 'silent' on these requirements.

When special class concrete is required the designation will be more complex as the special requirements of the concrete will need to be defined fully by the specifier who will need to

develop a suitable designation method. As a guide to this AS 1379 details the following prefixes to strength grade:

- S – Used for compressive strength specified mixes;
- SF – Used for flexural strength grades;
- ST – Used for indirect tensile strength specifications;
- SB – Used for durability exposure classification 'B2' (refer to AS 3600);
- SC – Used for durability exposure classification 'C1 & C2' (refer to AS 3600);
- SU – Used for durability exposure classification 'U' (refer to AS 3600).

6.2 NORMAL CLASS CONCRETE

Concrete designated in the specification as normal class will be required to comply with the requirements of section 15.

6.3 SPECIAL CLASS CONCRETE

Concrete designated in the specification as special class will be required to comply with the requirements of section 16.

6.4 SPECIAL CLASS PRECAST AND PRESTRESSED PRECAST CONCRETE

Concrete designated in the specification as special class precast and prestressed precast will be required to comply with the requirements of section 17.

7. MATERIALS

Concrete is composed of cement or blended cement (including SCM's), fine aggregate, coarse aggregate, admixtures, additives (if approved by the specifier), and water, proportioned and mixed as detailed in accordance with AS 1379 unless varied by this specification for specific special class concrete. All constituent materials will be required to conform to relevant Australian Standards

unless varied by the specifier in the concrete specification.

It is general practice that, where a specifier provides or specifies a full or partial mix design for a special class prescription concrete, the mass of coarse and fine aggregates are measured in a saturated surface dry condition (SSD) and usually based on a quantity per cubic metre of concrete.

7.1 CEMENT

This clause should be amended to include the type of cement preferred and the relevant standard that it is required to comply with. Typically, the type of cement may be specified according to AS 3972 from the following list:

- Type GP: General Purpose Portland;
- Type GL: General Purpose, Limestone blend;
- Type GB: General Purpose Blended;
- Type HE: High Early Strength;
- Type LH: Low Heat;
- Type SR: Sulfate Resisting;
- Type SL: Shrinkage Limited.

The most commonly used cement in Australia is Type GP (General Purpose) cement. Type GP cement is often blended with supplementary cementitious materials at the concrete plant to obtain the required mix properties, but blends are also produced by cement manufacturers as Type GB (General Purpose Blended cement). Other cements have special purposes as suggested by the list above and further information on these are available in the Guide, Part II, Sections 1 and 2.

A simple wording of a clause for this section is given in the following:

General purpose and blended cement shall comply with the requirements of AS 3972 or NZS 3122, 3123 or 3125. Type GP or GB cements shall be used unless otherwise specified or approved by the specifier.

Supplementary cementitious materials used in Type GB, Type LH, Type SR or Type SL cements shall comply with AS/NZS 3582.1, AS 3582.2 or AS/NZS 3582.3.

Acceptable cementitious products must hold a valid registration number issued by CemAssure Limited, or other third-party cementitious materials conformance assessment system as shall be demonstrated to be directly equivalent to CemAssure, endorsed by JAS-ANZ or equivalent, and approved as such in writing by the specifier.

Evidence of compliance with this clause must be obtained when contract bids are received.

Where 'special purpose' cements required in specialised concrete mixes (such as Type HE used in Special Class precast concrete) are to be supplied to a project then this is best tabled as noted in section 9.

7.2 SUPPLEMENTARY CEMENTITIOUS MATERIALS

Concrete mixes often use supplementary cementitious materials (SCM's) as part of a mix binder combination with cement. The common SCM's used in Australia are:

- Fly ash;
- Ground Granulated Blast Furnace Slag;
- Amorphous Silica;
- A blend of two or three of the three SCM types.

The following examples provide guidance on the compliance requirements for these materials. In each case their use may be required for various special purposes such as:

- Improve durability for concrete in aggressive environments;
- Reduce temperature rise in placed concrete;
- Reduce the risk of Alkali-Silica Reaction;
- Improve the plastic properties of concrete.

In each case there is a need to demonstrate that the performance characteristics of the concrete will be achieved. This can be achieved by verifying the results of trial mixes on concrete using these SCM's or verification of concrete supplier production data where the particular mix is routinely supplied and tested.

Examples of wording of clauses for use of SCM's are provided in sub-sections 7.2.1 to 7.2.4.

7.2.1 Fly Ash

Fly ash used shall comply with AS/NZS 3582.1 and be Special Grade or Grade 1 as defined by the Australian Standard. In addition to this, the achievement of AS 1379 minimum seven-day strength requirements and any specified properties of concrete mixes containing the design fly ash proportion of binder must be demonstrated by trial mixes or production test data for this concrete mix. Tests verifying compliance of the fly ash to the Standards shall be submitted to the designated authority with the proposed mix designs.

7.2.2 Ground Granulated Blast Furnace Slag

Ground granulated blast furnace slag shall conform to AS 3582.2. In addition to this, the achievement of AS 1379 minimum seven-day strength requirements and any specified properties of concrete mixes containing the design slag proportion of binder must be demonstrated by trial mixes or production test data for this concrete mix. Tests verifying compliance of the slag to the Standards shall be submitted to the designated authority with the proposed mix designs.

7.2.3 Amorphous Silica

Amorphous silica shall conform to AS/NZS 3582.3. In addition to this, the achievement of AS 1379 minimum seven-day strength requirements and any specified properties of concrete mixes containing the design amorphous silica proportion of binder must be demonstrated by trial mixes or production test data for this concrete mix. Tests verifying compliance of the amorphous silica to the Standards shall be submitted to the designated authority with the proposed mix designs.

7.2.4 Cementitious Blends

Where a blend of two or more of the SCM's are used, each component of the blend shall conform to the relevant Standard as noted in sub-sections 7.2.1 to 7.2.3. In addition to this, the achievement of AS 1379 minimum seven-day strength requirements and any specified properties of concrete mixes containing the

design SCM blend proportion of binder must be demonstrated by trial mixes or production test data for this concrete mix. Tests verifying compliance of the SCM blend to the Standards shall be submitted to the designated authority with the proposed mix designs.

Acceptable cementitious products must hold a valid registration number issued by CemAssure Limited, or other third-party cementitious materials conformance assessment system as shall be demonstrated to be directly equivalent to CemAssure, endorsed by JAS-ANZ or equivalent, and approved as such in writing by the specifier.

7.3 WATER

Mixing water shall be deemed to be of acceptable quality if (a) test results and service records of concrete made with that water indicate that it is not injurious to the strength or durability of the concrete or of the materials embedded in it; or (b) it has been suitably tested in a laboratory and the test results are within limits given in AS 1379.

Further information on water quality is available in the Guide, Part II, Section 4.

A simple wording of a clause for this sub-section is given in the following:

Water used in the manufacture of concrete shall meet the requirements of AS 1379. Tests verifying compliance of the water to AS 1379 shall be submitted to the designated authority with the proposed mix designs.

7.4 CHEMICAL ADMIXTURES

Chemical admixtures are used in concrete with the aim of benefitting placement and strength development of the concrete. For example, in climates subjected to freezing and thawing, air-entraining agents are recommended to improve the durability of the exposed concrete surfaces.

Appropriate admixture use should be proposed by the Contractor and these should be permitted provided the placed concrete meets design requirements. In some cases, a specifier may require a particular type of admixture or

admixture combination where it is used to achieve proven properties of the concrete.

An example of simple wording for this clause is given in the following:

Chemical admixtures shall comply with the requirements of AS 1478.1 and shall be used in accordance with Appendix B of that Standard. Admixtures shall not contain chlorides, or any other substance detrimental to concrete or reinforcing steel. Technical data sheets for each chemical admixture shall be submitted to the designated authority with the proposed mix designs.

7.5 CONCRETE AGGREGATES

This clause should specify the compliance of aggregates for the concrete mix, the test procedure and the associated limits where alternatives are provided in AS 2758.1.

For coarse aggregate, the maximum aggregate size must be specified.

Where the potential for Alkali-Aggregate Reaction risk is suspected, strategies to minimise the risk should be specified in accordance with AS HB 79 'Alkali-Aggregate Reaction – Guidelines on Minimising the Risk of Damage to Concrete Structures in Australia'. This publication will help a specifier to understand the practical issues raised by this phenomenon.

Typical strategies will depend on the relative risk of failure in the structure and may include:

- Limits to the total mass of reactive alkali in the concrete;
- Use of minimum levels of supplementary cementitious materials; and/or
- Testing of proposed aggregates and/or mix designs.

Detailed information on aggregates is available in the Guide, Part II, Section 3. Examples of wording of clauses for specification of aggregates are provided in sub-sections 7.5.1 and 7.5.2

7.5.1 Coarse Aggregates

Coarse Aggregate shall conform to AS 2758.1 unless specified otherwise. Each type and source of aggregate shall be tested separately. Testing of coarse aggregate for use in concrete shall be carried out as detailed in **Table XI.4** and preliminary test results on coarse aggregates submitted to the designated authority with the proposed mix designs.

Table XI.4 – Coarse Aggregate Testing

Test Method	Testing Standard	Acceptable Limits
Grading	AS 1141.11.1	AS 2758.1 App. B
Flakiness Index	AS 1141.15	<35%
Particle Density	AS 1141.6.1	2.1-3.2 T/ m ³
Water Absorption	AS 1141.6.1	<3.0%
Wet Strength	AS 1141.22	>100 KN
Wet/Dry Variation	AS 1141.22	<25%
Alkali Reactive Materials	AS 1141.60.1 AS 1141.60.2	AS HB 79 Non-reactive
Weak Particles	AS 1141.32	<0.5%

7.5.2 Fine Aggregates

Fine Aggregate shall conform to AS 2758.1 unless specified otherwise. Each type and source of aggregate shall be tested separately. Testing of fine aggregate for use in concrete shall be carried out as detailed in **Table XI.5** and preliminary test results on fine aggregates submitted to the designated authority with the proposed mix designs.

Table XI.5 – Fine Aggregate Testing

Test Method	Testing Standard	Acceptable Limits
Grading	AS 1141.11.1	AS 2758.1 App. B
Material finer than 75 microns	AS 1141.12	<5% Nat. Sand <20% Man. Sand
Particle Density	AS 1141.6.1	2.1-3.2 T/ m ³
Water Absorption	AS 1141.6.1	<3.0%
Chloride Content	AS 1012.20.2	<0.008%
Sulfate Soundness	AS 1141.24	<6.0% Loss
Alkali Reactive Materials	AS 1141.60.1 AS 1141.60.2	AS HB 79 Non-reactive
Deleterious Fines Index	AS 1141.66	<150
Organic Impurities	AS 1141.34	Lighter than standard

7.6 CONCRETE ADDITIVES, COLOURS AND FIBRES

Some Special Class concrete mixes may be required to contain various forms of solid additives that are not covered by sub-sections 7.1 to 7.5. These may include, but are not limited to:

- Solid mineral additives such as clays, chemical additives not covered by AS 1478.1 and cementitious materials not detailed in sub-sections 7.1 and 7.2;
- Colouring Oxides;
- Fibres – both steel and synthetic types.

The specifications of these are discussed in the following sub-sections.

7.6.1 Solid Mineral Additives

In some circumstances, materials are added to concrete to produce an enhancement of the concrete plastic properties or hardened properties. In the case that these materials do not have a relevant Standard for their use in

concrete then the supplier will be required to warrant their use and recommend appropriate dose rates for the material in the concrete mix. This recommendation should be supported by trial mix and test data.

7.6.2 Colours

If coloured concrete is required and the colour is achieved through cement colour, the type of cement to be used (e.g. Off-White, White or grey) and possibly the cement source should be specified. The availability of colours should be checked prior to specification. Normally it is sufficient to nominate a particular manufacturer's colour without specifying a dosage rate. Often a particular cement colour is combined with pigments to produce the required colour. The responsibility for producing the colour with the specified concrete mix then rests with the concrete supplier. For colours outside the standard range, a dosage rate for the specific concrete mix may need to be established via test panels. Acceptance of test panels will be subject to approval by the specifier or the designated authority.

Examples of simple wording for this clause are given in the following:

The concrete shall incorporate [specify colour of cement] from [specify producer] and shall incorporate [specify pigment product and supplier] pigment at a dosage rate of [quantity % by weight of cement].

The concrete shall incorporate [specify colour of cement] from [specify producer] and [specify pigment product and supplier] pigment at a dosage rate of [quantity % by weight of cement].

7.6.3 Fibres

In some forms of special class concrete fibres are incorporated to provide improved properties of the plastic or hardened concrete. Care should be taken to ensure that the fibres most appropriate for the application are used. The supplier, fibre type and dose rate or concrete fibre reinforced concrete performance requirements should be specified in addition to the relevant material standards for the fibres.

In the case of structural synthetic fibres or steel fibres the expected minimum properties of the

concrete incorporating these fibres may be specified. These properties may include minimum tensile strength at various CMOD values (refer AS 3600 or EN 14651).

Information regarding specification of fibres is available in the Guide, Part I and Part II, Section 7.

Examples of typical wording for this clause are given in the following:

The concrete shall incorporate [specify fibre product and supplier] at a dosage rate of [quantity kg per m³ of concrete].

Properties of synthetic fibre reinforced concrete:

Synthetic fibre reinforced concrete shall possess the following properties:

- *Average residual strength (ASTM C1399) > [X] MPa;*
- *Flexural toughness (ASTM C1609) > [Y] MPa;*
- *The % of flexural strength at 3 mm deflection of standard beam test (Flexural toughness factor to ASTM C1609) > [N]%.*

7.7 CURING COMPOUNDS

Spray-on liquid membrane curing compounds are one common method of curing concrete exposed surfaces after finishing. Where curing compounds are used, the properties need to be defined to ensure compatibility of the curing compounds with any other applied finishes that are proposed to be used. Discoloration of the concrete surface may or may not be a major concern.

Of the many types of liquid membrane-forming curing compounds available, the wax-based emulsions and chlorinated rubber types are preferred and recommended. Recent research has shown that special safety precautions are necessary for the use of chlorinated rubber compounds. A white pigmented dye is recommended to facilitate checking that the concrete surface has been fully sprayed.

Wax-based curing compounds are generally efficient in terms of moisture retention but can

create safety concerns by producing a slippery surface on the concrete. For this reason, it is recommended that they not be used on surfaces subject to early foot or vehicular traffic.

Liquid membrane curing compounds need to be effective and appropriate test methods to assess this are provided in AS 3799. An example of simple wording for this clause is given in the following:

Liquid membrane-forming curing compounds shall comply with the requirements of AS 3799 and be applied at a dosage rate as per the manufacturer's specifications. The supplier shall provide a certificate of compliance and NATA-endorsed test certificate showing compliance to the Australian Standard.

8. STORAGE OF MATERIALS

While much of the concrete produced in Australia is sourced from fixed location premixed concrete plants that generally have material storage facilities that are fully compliant with the requirements of AS 1379, this is not always the case where concrete may be produced from temporary 'project' plants. This may require a section of the concrete specification detailing storage requirements. Two key areas where appropriate storage of materials has a direct impact on the quality assurance of the concrete are the binder storage and the aggregate storage. Examples of suitable wording for specification of storage for these two material types are provided in the following sub-sections.

8.1 CEMENTITIOUS MATERIALS

Bulk cement and SCM's shall only be stored in watertight silos. Bagged cement and SCM's shall be stored above ground and level in dry, weatherproof sheds and be protected from dampness which may be acquired from contact with floors or walls. Bags shall be stacked so as to allow counting, inspection and identification of each consignment. As far as practicable, cement shall be used in order of receipt.

8.2 AGGREGATES

Aggregates shall be stored on a hardstand or in silos. Aggregates shall be stored in such a manner as to avoid segregation, becoming contaminated by foreign matter, or becoming intermixed. Stockpiles shall be arranged to prevent entry of adjacent surface or ground water and to allow free drainage of rainwater.

9. CONCRETE MIX DESIGN AND ACCEPTANCE

The specifier or the designated authority will generally be required to review the proposed concrete mix designs for a project. This is particularly so in the case of special class concrete. In the case of normal class concrete the specifier may seek to sight and verify production assessment reports for the supply plant only. In either case, the provision of documented mix designs, concrete constituent material test reports and concrete test reports is likely to be a 'Hold Point' as noted in section 5 of this document.

It is important that the construction contractor is responsible for (a) the management of concrete mixes on the construction site, (b) what approved concrete mixes are used and (c) where they are to be used on the site. The contractor will typically need to submit the following detail for each special class concrete to be used on site:

- Mix code and version;
- Intended application (e.g. in-situ, precast, sprayed, extruded, piling (dry), or piling (wet) etc.);
- Strength grade of concrete;
- Nominated slump or slump spread;
- Name of the concrete supplier;
- Location of batch plant;
- Types, proportion by mass, sources of the various constituent materials;
- Test results on aggregate product test properties (sub-section 7.5);
- Average 28-day strength with standard deviation (sub-section 9.3);
- Chloride content of hardened concrete (sub-section 9.7);
- Concrete durability test values (sub-

section 9.6);

- Other test information – for example drying shrinkage testing (sub-section 9.9), sulfate testing (sub-section 9.8) and/or other material test certificates may be required on a mix or project basis.

As well as submitted mix designs there are also controls required on the testing of concrete used on the project to ensure that at least the minimum requirements of AS 1379 are being maintained.

9.1 SLUMP AND SLUMP SPREAD

The specification of slump by the design engineer is not generally recommended as this may restrict methods used by the contractor. AS 1379 states that the concrete shall be deemed to comply with the specified slump, if the measured slump is within the tolerance for slump given in **Table XI.6**.

Table XI.6 – Permissible Tolerance on Slump (AS 1379)

Specified Slump Range (mm)	Tolerance (mm)
< 60	+/-10
≥60 ≤80	+/-15
>80 ≤110	+/-20
>110 ≤150	+/-30
>150	+/-40

Where Super-workable concrete is specified there may be a need to carry out a number of tests on the concrete that may not apply to normal class or special class concrete with a specified slump under 220 mm (refer to the Guide, Part VI, Section 22 and Part VIII, Section 25 for more information on Super-workable Concrete). A common test for Super-workable Concrete consistency is the slump flow test. Typical specified Slump Flow values will range from 550 mm to 700 mm. Common acceptance tolerances on slump flow are provided in **Table XI.7**.

Table XI.7 – Typical Tolerance on Slump Flow (AS 1012.3.5)

Specified Slump Flow (mm)	Tolerance (mm)
550	+/-50
600	+/-50
650	+/-50
700	+/-50

Other values can be obtained from the slump flow test including T_{500} (AS 1012.3.5) and Visual Stability Index or VSI (ASTM C1611). Refer to the Guide, Part VI, Section 22 and Part VIII, Section 25 for more information on these tests and references.

The frequency of slump or slump flow testing should be specified at least at the same frequency of compressive strength testing. In the case that Production Assessment in accordance with AS 1379 is provided then the minimum frequency is 1 per 100 m³ of concrete supplied. If Project Assessment is specified at the project site, then the frequency is at least 1 per 50 m³. In some cases of special class concrete or a critical element or group of elements in a structure it may be justified to increase the frequency of testing to more than that required by AS 1379.

9.2 AIR CONTENT COMPLIANCE

Where air content is specified for concrete the frequency of sampling and testing is recommended to be in every alternate test sample for compressive strength. This suggests a test frequency of 1 sample per 100 m³ of concrete. In some cases, this will be adequate but it may be useful to assess the first two batches of concrete in every day's supply to ensure that adjustments to air entraining agent can be made early in a supply if required.

Compliance to specified air content is recommended to be within a tolerance of +/- 1.5% of the target value. Where air content control is critical this tolerance may be reduced to +/- 1.0% of the target with an increased frequency of testing.

An example of simple wording for this clause is given in the following:

Where the concrete mix air content is specified the air content shall be sampled and tested at a frequency of 1 sample per 100 m³. The concrete shall be deemed as conforming if measured air contents are within 1.5% of the specified value.

9.3 COMPRESSIVE STRENGTH COMPLIANCE

Concrete compressive strength compliance is generally assessed at 28 days after casting. Compliance assessment methods are provided in AS 1379 and these expect that sampling and testing will be carried out in accordance with AS 1012.8.1 and AS 1012.9. The details of assessment are provided in the Guide, Part VIII, Section 26.

Examples of simple wording for this clause are given in the following:

The concrete compressive strength shall be sampled and tested in accordance with AS 1012.8.1 and AS 1012.9. Test data from the project site will be assessed using 'Project Assessment' in accordance with AS 1379. The concrete supplier shall carry out 'Plant Assessment' in accordance with AS 1379 for all strength grade concrete supplied from the plant supplying concrete to the project site. If requested by the construction contractor, the concrete supplier shall provide a Production Assessment report in accordance with AS 1379 for verification.

In some cases of special class concrete strengths at earlier ages (for post tensioning, stripping forms or lifting precast elements) or a later age strength than 28-days (such as 90-day strength for low heat mass concrete) may be specified as a characteristic strength. It is recommended that testing and assessment of these alternative age test specimens is specified using the same method and formulae as for 28-day strength in AS 1379 except with variation for the period of curing the test specimens.

The frequency of compressive strength testing should be specified as 'in accordance with AS 1379' for Production Assessment (1 sample per 100 m³ of concrete supplied) or for Project assessment (1 sample per 50 m³). In some cases of special class concrete or a critical element or group of elements in a structure it may be justified to increase the frequency of testing to more than that required by AS 1379.

An example of simple wording for this clause is given in the following:

Compressive strength concrete samples shall be taken on site at a frequency in accordance with AS 1379 for Project Assessment. From each sample at least 3 test cylinders will be cast (1 cylinder for 7-day assessment and 2 cylinders for 28-day assessment). Specimens will be cast, cured and tested in accordance with AS 1012.8.1 and AS 1012.9.

9.4 TENSILE STRENGTH COMPLIANCE

Concrete tensile strength can be specified in lieu of compressive strength or in conjunction with compressive strength. Typically, this will be either Indirect Tensile Strength or Flexural Tensile Strength. More details are provided for these tests in the Guide, Part VIII, Sections 25 and 26.

In AS 1379 two methods of assessing compliance of tensile strengths are provided:

- Using an equivalent target flexural strength and compressive strength so as to use compressive strength assessment as a means of controlling tensile strength;
- Using the same methods and formulae as for compressive strength assessment except applying these to a specified characteristic tensile strength (Flexural or Indirect) and with standard deviation measured from the tensile strength at 28-days or nominated assessment curing age.

The reason for the first assessment option in AS 1379 is recognition of the extremely high variability of tensile tests (particularly flexural strength testing which typically has a coefficient of variation between 50% and 100% greater

than that of compressive strength for the same concrete).

One flaw in using the second assessment method is that while AS 1379 has guidance on maximum pair differences for compressive strength at 28 days (for pairs of compressive strength tests from the same sample of concrete and tested at 28 days), no such guidance is provided for flexural or indirect tensile strength pair differences. The very high variability of tensile strength tests is partly attributable to weaknesses in the test methods that lead to the effects of any inconsistency in the test sample significantly impacting on the test value.

An example of simple wording for this clause is given in the following:

Flexural tensile strength concrete samples shall be taken on site at a frequency in accordance with AS 1379 for Project Assessment. From each sample at least three test beams will be cast (1 beam for 7-day assessment and 2 beams for 28-day assessment). Specimens will be cast, cured and tested in accordance with AS 1012.8.2 and AS 1012.11. Assessment of

the strength of conforming test beams cured to 28 days may be carried out using the method applied to compressive strength production assessment and project assessment in AS 1379. The standard deviation for flexural strength of a concrete mix will be calculated from a minimum of 15 conforming samples. Any samples with a pair difference greater than 15% of the average strength of the pair at 28 days will be deemed as non-conforming and rejected for the purpose of assessment.

9.5 SPECIFIC EXPOSURE CLASS REQUIREMENTS

Concrete structures designed in accordance with AS 3600 will require that the concrete meets certain durability requirements in accordance with exposure classifications relevant to the environment in which the concrete is placed. AS 3600 directs six of the seven exposure classes to using minimum strength grade concrete along with minimum curing requirements. These classes, minimum strength grade and relevant minimum curing are summarised in **Table XI.8**.

Table XI.8 – AS 3600 Concrete Exposure Requirements

Exposure Classification	Minimum Strength Grade of Concrete (MPa)	Minimum average strength at the time of removing forms (MPa)	Minimum period of curing (Days)
A1	20	15	3
A2	25	15	3
B1	32	20	7
B2	40	25	7
C1	50	32	7
C2	50	32	7
U	Not Specified	Not Specified	Not Specified

The AS 2758.1 concrete aggregate testing assessment requirements also vary for concrete in the same exposure classes as used in AS 3600. Acceptable test values for coarse and fine aggregate vary from classes A1 & A2 to B1 & B2 and again to C1 & C2 and impact on Sulfate Soundness, Wet/Dry Strength and Los-

Angeles Abrasion Resistance test requirements. More information on these requirements can be found in the Guide, Part II, Section 3.

When designs are carried out for concrete piles (AS 2159), concrete bridges (AS 5100.5), concrete liquid retaining structures (AS 3735) or

concrete maritime structures (AS 4997), each Standard has a similar (but different) set of exposure classifications that are specific to design for durability in their specific environments. Care needs to be exercised when specifying concrete mixes in these environments as each case where concrete in excess of N32 grade concrete is specified, it may become a special class concrete by virtue of the definition of special class concrete in AS 1379 (minimum binder content, recommended binder compositions and maximum water/binder ratios may apply). Where special class concrete requirements need to be specified, these will be detailed in additions to section 7 clauses and noted in sub-section 16.1.

9.6 TESTING FOR CONCRETE DURABILITY

Where concrete is required to meet specific durability requirements it will automatically become a special class concrete by the definition of special class concrete in AS 1379. There are many test methods for various aspects of concrete durability. These can include but are not limited to:

- Water permeability;
- Gas permeability;
- Surface absorption rate;
- Pore size and volume;
- Volume of permeable voids;
- Chloride diffusion;
- Carbonation rate;
- Concrete electrical resistivity.

For each of these general properties there may be a single test method or many test methods. Most of the test methods have not been incorporated into Australian Standards but are easily found as international standards and referenced. Many related documents and papers can provide useful advice on the use and assessment of test data.

If a special class concrete cast into a structural element is placed into an environment where a single or multiple durability property of the concrete is critical to achieving a design life that is not adequately covered by the design

standards prescriptive requirements, then the specifier may need to specify a test method, assessment method, testing frequency and compliance details for this property.

An example of simple wording for this clause is given in the following:

Type SC50/20/120 special class concrete will be assessed for chloride diffusion coefficient using test method ASTM C1556. Test frequency will be testing the trial mix at least three months prior to supply and then testing samples every three months during supply. The trial mix Diffusion Coefficient at 56 days shall be less than $3.0 \times 10^{-12} \text{ m}^2/\text{s}$. During supply of SC50/20/120, test values exceeding $3.9 \times 10^{-12} \text{ m}^2/\text{s}$ will be deemed to be non-conforming.

9.7 CHLORIDE CONTENT TESTING

AS 1379 requires concrete production from a supply plant to be assessed for its chloride content by assessing the most frequently sampled concrete at a frequency of at least 1 test every 6 months. In the case of project assessment of concrete, the specifier may choose to target testing of more critical special class concrete for chloride content at stages during the supply of concrete to the construction site. The limit on chloride content of normal class concrete in AS 1379 is calculated as a mass of chloride ions per unit volume of concrete with a maximum limit of 0.80 kg/m³. The frequency of testing will be increased if any changes of concrete constituent materials are made by the supplier or detected (e.g. a new source of sand).

Because low chloride content is critical for protection of reinforcing steel and that pre-stressing steel may require even lower limits of chloride in the concrete than normal reinforcement, it is possible that the limits on chlorides may be reduced on some special class concrete mixes used in particular concrete elements.

Two methods for testing the chloride content are now available (i.e. AS 1012.20.1 and AS 1012.20.2). The original method, AS 1012.20.1, uses acid extraction of chlorides from the concrete, whereas AS 1012.20.2 uses

water extraction of chlorides from the concrete. The compliance limits for chlorides in AS 1012.20.2 will be lower than those currently provided in AS 1379. Guidance on AS 1012.20.2 limits for aggregates are provided in AS 2758.1 and if AS 1012.20.2 is used for normal class concrete it would be expected that a limit of water-soluble chlorides will be reduced to 0.60 kg/m³. The reason for using the water-soluble method relates to certain aggregates (rare) that have chloride ions 'locked' in some of the minerals forming that aggregate. It has been determined that in these cases, the acid extraction will liberate these chlorides that would not generally be available to the concrete pore water solutions and therefore not be harmful to reinforcement. The water extraction method avoids picking up these 'locked' chlorides.

AS 1379 requires expression of chlorides as a mass (kg) in a cubic metre of concrete. AS 1012.20.1 and AS 1012.20.2 express the chloride as a percentage of the dry mass of concrete. In order to calculate the mass of chloride ions per m³ of concrete, the percentage value from AS 1012.20.1 (or AS 1012.20.2) are multiplied by the density of that concrete in oven dry condition. This can be assessed on an un-cured test specimen where the specimen is oven dried at 105°C to a constant mass (less than 1 gram change over 24 hours) and density measured using the method in AS 1012.12.1 before being submitted for chloride testing. The dry density may also be estimated from the mix design by summing up the dry mass of each solid ingredient in a cubic metre of concrete. The calculation is simple – multiply the % by weight of concrete by the dry density (in kg/m³). For example: a concrete test specimen has a dry density of 2,260 kg/m³ and a chloride content of 0.021% – then the chloride content = $2,260 \times 0.021/100 = 0.47 \text{ kg/m}^3$.

The concrete supplier or testing authority will provide a report containing these results and supporting test certificates where more than one laboratory has carried out this assessment.

Examples of simple wording for this clause are given in the following:

Normal class concrete will be assessed for chloride content of concrete using test methods

AS 1012.20.1 or AS 1012.20.2 every 6 months. Any approved change of concrete constituent materials during supply will initiate re-testing. A report verifying the chloride content of the concrete in kg/m³ shall be submitted to the construction manager. Chloride content of concrete in excess of the limit set in AS 1379 will be deemed as non-conforming.

Special class concrete mix SB40/20/80 will be assessed for chloride content of concrete using test method AS 1012.20.1 every 1,000 m³ of supply of this mix. Any approved change of concrete constituent materials during supply will initiate re-testing. A report verifying the chloride content of the concrete in kg/m³ shall be submitted to the construction manager. Chloride content of concrete in excess of 0.40 kg/m³ will be deemed as non-conforming.

9.8 SULFATE CONTENT TESTING

AS 1379 requires concrete production from a supply plant to be assessed for its sulfate content by assessing the most frequently sampled concrete at a frequency of at least 1 test every 6 months. In the case of project assessment of concrete, the specifier may choose to target testing of more critical special class concrete for sulfate content at stages during the supply of concrete to the construction site. The limit on sulfate content of normal class concrete in AS 1379 is calculated as a mass of sulfate (as SO₃) per mass of cement (binder) in the concrete with a maximum limit of 50 gm/kg. The frequency of testing will be increased if any changes of concrete constituent materials are made by the supplier or detected (e.g. a new source of sand).

In this case the sulfate content is again assessed by the test method of AS 1012.20.1. The reported value of sulfate will be expressed as a percentage of the dry concrete sample. To convert this to a proportion by weight of cement the following formula is used:

Mass of sulfate (gm) per kg of binder = [% Sulfate per mass of dry concrete × Dry density of concrete (kg/m³)/ Mass of binder (cement + SCM) (kg/m³) × 1,000].

For example, if the sulfate content of the concrete = 0.35% of dry concrete, the concrete dry density equals 2,260 kg/m³ and the binder content equals 380 kg/m³, then the mass of sulfate (gm) per kg of binder = $0.35/100 \times 2,260/380 \times 1,000 = 20.8$ gm/kg.

An example of simple wording for this clause is given in the following:

Normal class concrete will be assessed for sulfate content of concrete using test method AS 1012.20.1 every 6 months. Any approved change of concrete constituent materials during supply will initiate re-testing. A report verifying the sulfate content of the concrete in gm per kg of total binder shall be submitted to the construction manager. Sulfate content of concrete in excess of the limit set in AS 1379 will be deemed as non-conforming.

9.9 DRYING SHRINKAGE TESTING

AS 1379 requires concrete production from a supply plant to be assessed for its drying shrinkage by assessing the most frequently sampled concrete at a frequency of at least 1 test every 6 months. In the case of project assessment of concrete, the specifier may choose to target testing of more critical special class concrete for drying shrinkage at stages during the supply of concrete to the construction site. The (maximum) limit on drying shrinkage for normal class concrete in AS 1379 is 1,000 micro-strain at 56 days. It is important to note that the maximum drying shrinkage for normal class concrete is applied to individual test sample results and not to the mean or average test result. The coefficient of variation of drying shrinkage testing on a single mix can be around 10% of the tested value. In view of this 90% of tests on concrete with an average drying shrinkage of 850 micro-strain will be likely to range between 700 and 990 micro-strain. In view of this the upper limit of 1,000 micro-strain for an individual test is a reasonable method of controlling the drying shrinkage of normal class concrete and suggests a maximum average drying shrinkage of approximately 850 micro-strain at 56 days.

The frequency of testing will be increased if any changes of concrete constituent materials are

made by the supplier or detected (e.g. a new source of aggregate or cement).

In some projects the specifier will determine that a lower drying shrinkage limit will be specified for a special class concrete. In this case the specifier will need to determine a method of assessing the concrete compliance based on the testing frequency. Based on this information, the mix designer can establish a mix design that will provide a suitable target average shrinkage to comply.

An example of simple wording for this clause is given in the following:

Special class concrete mix 'S40/20/80/700µm' shall be designed to provide a maximum individual sample drying shrinkage of 700 micro-strains at 56 days when sampled and tested in accordance with AS 1012.8.4 and AS 1012.13. The basis of assessment of this mix will be a trial mix with drying shrinkage less than 600 micro-strains at 56 days prior to use of this concrete on site. The sampling and testing frequency on this mix will be one sample for every 200 m³ of 'S40/20/80/700µm' concrete on site. Compliance of this supply will be verified by monitoring the average shrinkage value of 5 consecutive samples tested for drying shrinkage at 56 days. Concrete represented by these 5 consecutive samples will be deemed not to comply if any single test sample shrinkage exceeds 700 micro-strains at 56-days or if the average of the 5 consecutive samples exceeds 660 micro-strains at 56 days.

10. BATCHING, MIXING AND TRANSPORT OF CONCRETE

Concrete may be provided by a concrete supplier with a fixed plant off the project site or may be produced through a concrete plant on site. In either case the requirements for batching concrete, mixing and transport of the concrete should conform to requirements detailed in AS 1379.

10.1 BATCHING

An example of simple wording for this clause is given in the following:

Aggregates and all cementitious material shall be batched by mass in accordance with the tolerances provided in AS 1379. Approved liquid admixtures may be batched by weight or volume in accordance with the tolerances provided in AS 1379. Water may be batched by mass or by volume in accordance with the tolerances provided in AS 1379. Batch records for each batch must be available at the plant for at least 12 months should they be required for auditing. Each batch of concrete will be accompanied with a certificate (docket or ticket) with details of the batch as required by AS 1379.

10.2 MIXING

An example of simple wording for this clause is given in the following:

Concrete shall be mixed in a mixer of an appropriate type having a capacity suitable for the type of work being undertaken. The mixer drum or mixing paddles shall rotate at the speed recommended by the manufacturer. The volume of mixed concrete in the batch shall not exceed the rated capacity of the mixer. Mixing time shall be in accordance with testing of the prototype mixer to determine a mixing time that achieves mixer uniformity as detailed in AS 1379 Appendix A.

10.3 TRANSPORT AND DELIVERY

An example of simple wording for this clause is given in the following:

The timing of deliveries shall be such as to ensure an essentially continuous placing operation. Concrete shall be placed and compacted within the 90 minutes of the batched load leaving the batch plant. This time may be extended if the supplier and construction contractor agree that a slump loss control admixture or set-retarding admixture can be used to maintain mix consistency without the addition of excess water.

11. ACCEPTANCE AND REJECTION OF PLASTIC CONCRETE

The consistency and workability of concrete needs to be selected so that it can be handled and transported without segregation and can be placed, worked and compacted into the forms and around all reinforcement.

The consistency of concrete will generally be checked by means of the slump or slump spread test. Some very low slump, special class concrete may be assessed by compacting factor tests. Sampling is carried out in accordance with AS 1012.1 and testing by AS 1012.3.1 or AS 1012.3.5. Sampling and testing should be conducted by a NATA-accredited laboratory and reported as a NATA-endorsed test report.

The assessment of conformance will be the measured slump being within the tolerances of the specified slump (refer to **Tables XI.6** and **XI.7** in sub-section 9.1).

Action on non-conformance is generally to reject batches of concrete with out-of-tolerance slump but if the measured slump is below the lower tolerance it may be possible to add water to raise the slump within permissible tolerances provided the concrete supplier can demonstrate that the additional water will not exceed a water/cement ratio requirement or cause the mix to be non-conforming in any other hardened concrete properties (strength, durability, shrinkage or others) and that the construction contractor or specifier approve this adjustment.

An example of simple wording for this clause is given in the following:

*The consistency of concrete shall be sampled and tested in accordance with AS 1012.3.1 (for concrete other than super-workable concrete) or AS 1012.3.5 (for super-workable concrete). The testing frequency shall be in accordance with 'Project Assessment' testing in AS 1379. Concrete will be subject to rejection if the measured slump exceeds the relevant tolerance provided in **Tables XI.6** and **XI.7** in sub-section 9.1.*

Plastic concrete may be rejected on the basis of the air content being outside the tolerances required of specified target air content. Details of this are provided in sub-section 9.2.

A batch of plastic concrete may also be rejected if its colour or general appearance is very different to that of prior batches of the same mix.

12. ACCEPTANCE AND REJECTION OF HARDENED CONCRETE

The general requirements for testing and acceptance of hardened concrete have been provided in sub-sections 9.3, 9.4, 9.6, 9.7, 9.8 and 9.9. More specific requirements are listed in sections 16 and 17.

13. ENVIRONMENTAL LIMITS FOR CONCRETING OPERATIONS

The ambient environment in which concrete is manufactured, transported and placed has a significant impact on the hardened properties of concrete and potential for cracking of exposed surfaces of concrete. Factors such as ambient temperature, humidity and wind speed are part of these effects as is the temperature of the concrete on delivery and in its final state. To assist in controlling this AS 1379 places limits on the delivered temperature of concrete. In addition to this the effects of evaporation from the exposed surface of concrete during placement (such as foundations and slabs) may lead to cracking and durability issues (refer to the Guide, Part V, Section 18 and Part V, Section 17 for more information).

13.1 TEMPERATURE LIMITS

An example of simple wording for this clause is given in the following:

No concrete shall be placed on the project that has a measured temperature less than 5°C or greater than 35°C. Where the maximum air temperature is likely to exceed 30°C or be less than 10°C the construction contractor shall take action to ensure that the temperature limits will be adhered to.

13.2 ENVIRONMENTAL LIMITS

High rates of evaporation of bleed water from the surface of concrete can lead to premature stiffening of the concrete surface as well as setting up of stresses within the concrete surface that can lead to early cracking (plastic cracking) of the finished surface and potential for related longer term durability problems. The evaporation rate is linked to a combination of concrete temperature, air temperature, air relative humidity and wind speed. **Figure XI.1** provides a graphical method of estimating the likely evaporation rate of bleed water from the concrete surface. The following sub-sections explore assessment of evaporation and its control.

13.2.1 Estimation and Control of Evaporation Rates

When the predicted evaporation rate during the intended period of placement and finishing exceeds 0.50 kg/m²/h there is a reasonable probability that the exposed surface of a concrete slab (particularly strength grades in excess of 32 MPa) will dry too quickly and increase the risk of plastic cracking. When the evaporation rate exceeds 1.00 kg/m²/h plastic cracking of all concrete slabs is almost certain.

The evaporation rate can be calculated using the following parameters measured at the site:

- Air temperature (measured with a calibrated thermometer);
- Wind velocity (measured with a handheld or fixed anemometer);
- Relative humidity of the air (measured with a handheld or fixed psychrometer);
- Concrete temperature (Measured with a calibrated thermometer).

Figure XI.1 can be used for estimating the evaporation of surface moisture from the concrete for the construction site.

Control measures that can be used to reduce the evaporation rate include:

- Reducing the concrete temperature (adding ice to the mix, shading or cooling aggregates etc.);
- Erecting protective barriers around the construction area where the slab is being

- placed to reduce the wind velocity;
- Application of water mist sprays to increase humidity above the slab surface;
- Application of surface evaporation retardant (e.g. aliphatic alcohol) sprays to the concrete surface.

An example of simple wording for this clause is given in the following:

The evaporation rate shall be monitored by the Contractor during concreting operations until such time as curing commences. If control measures are not successful or are impractical, no concrete shall be poured.

13.2.2 Application of Evaporation Retarding Compound

The use of an evaporation retarding compound on the top surface of the concrete is recommended during placing of concrete slabs. It should be applied within 10 minutes of concrete placement and initial levelling. The compound is applied again following any subsequent floating.

Evaporation retardant compounds will consist primarily of aliphatic alcohol suitable for use on concrete.

Evaporation retardants do not replace curing compounds.

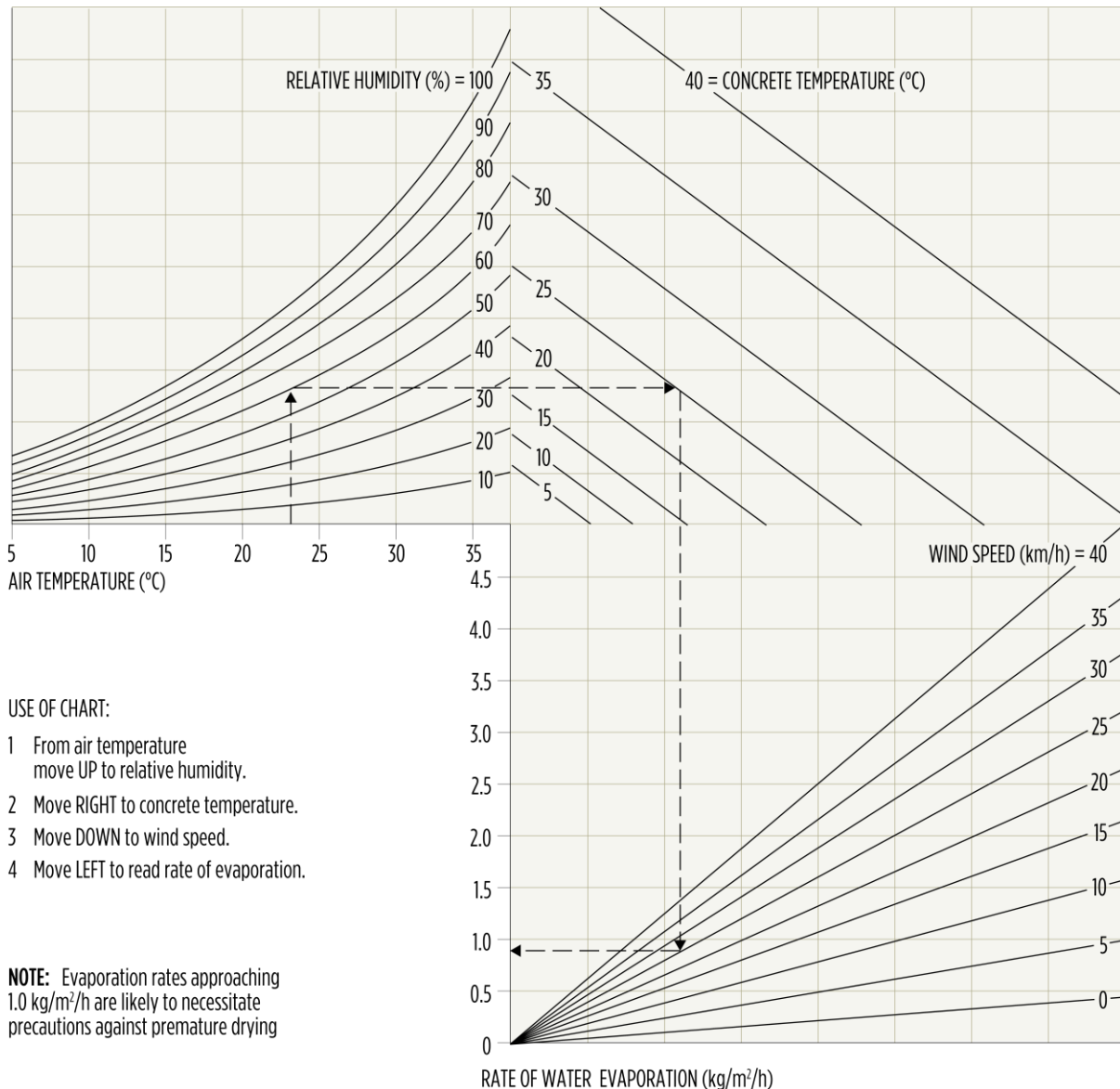

Figure XI.1 – Effect of concrete and air temperatures, relative humidity and wind velocity on the rate of evaporation of surface moisture from concrete (after ACI 305 (1999) [2])

An example of simple wording for this clause is given in the following:

Where weather conditions on site indicate an evaporation rate from the concrete surface is likely to exceed 0.50 kg/m²/h, the use of evaporation retardant mist sprays on the concrete slab exposed surface are mandatory. Sprays must be mixed in accordance with the manufacturer's instructions and applied within 10 minutes of concrete placement and initial levelling. Sprays are then applied again following any subsequent floating operation on the concrete surface.

13.3 PROTECTION FROM RAIN

Concrete should not be poured in the rain or if rain is imminent, unless adequate measures are taken to protect the plastic concrete from the damage caused by rain. Suitable protection may include a waterproof covering to protect all exposed surfaces of the concrete. All water should be removed from the forms before concrete is poured.

The effects of significant rainfall during concrete placement may include:

- Increased consistency of the concrete;
- Ponding of water on the surface;
- Disturbance (cratering) of concrete surface.

Concrete which is exposed to significant rain from the time of commencement of placement to the commencement of curing may be subject to rejection.

An example of simple wording for this clause is given in the following:

Concrete shall not be poured in the rain or if rain is imminent, unless adequate measures are taken to protect the plastic concrete from the damage caused by rain. Suitable protection may include a waterproof covering to protect all exposed surfaces of the concrete. All water should be removed from the forms before concrete is poured. Concrete which is exposed to significant rain from the time of commencement of placement to the commencement of curing will be subject to rejection.

13.4 CURING OF CONCRETE

All concrete must have a planned method for curing. Generally, the construction contractor will need to provide a method statement detailing the proposed methods to be used on site that ensure that the requirements for curing set out in sections 15 to 17 can be achieved.

Curing can be achieved through the application of water. The two difficulties with water curing are a) the ability to maintain the water in place for the curing period and b) the potential of excessive water running into foundations and causing damage. One method of keeping water on a concrete slab surface is using wet hessian on the surface as this takes less water to maintain the curing in place.

It is common practice to use liquid membrane-forming curing compounds which are defined in AS 3799. Where curing compounds are used, the properties need to be defined to ensure compatibility of the curing compounds with other applied finishes. Discoloration of the concrete surface may or may not be a major concern with this form of curing.

Impermeable sheet materials can be used to cure concrete and will need to meet the requirements of ASTM C171. When impermeable sheet materials are used, they must be anchored down and joints in material taped to ensure effectiveness. On large flat surfaces they may present a safety hazard for slipping for foot traffic.

Curing can be achieved by retention of formwork. In this case it is important that the formwork is not moved or removed during the curing period.

Curing needs to commence as soon as practicable, but no more than three hours after completion of the finishing operations of any unformed finishes.

Further details on curing of concrete are provided in the Guide, Part V, Section 15.

14. DEFECTS AND RECTIFICATION

The following wording is a common approach to rectification, but the precise responsibility and wording is up to the specifier:

Where concrete does not comply with the requirements listed in this Specification, the following options are permitted, at the discretion of the Specifier:

- *The concrete, and any portion of the structure built on the non-conforming concrete shall be removed and replaced with conforming concrete; or*
- *The non-conforming concrete, and any product containing that concrete, shall be replaced; or*
- *The non-conforming concrete may remain in place and additional works, approved by the Specifier, shall be undertaken to achieve adequate appearance, strength and durability.*

15. NORMAL CLASS CONCRETE FOR IN-SITU, PRECAST AND PRECAST-PRESTRESSED APPLICATIONS

This section applies to in-situ and precast concrete elements, where the drawings require normal class concrete. Normal class concrete is defined in AS 1379.

15.1 CONCRETE CLASS

The strength grade of concrete and maximum nominal aggregate size used shall be as specified on the Drawings. The specified concrete slump for any structural element is to be a default of 80 mm, or as recommended by the construction contractor to the specifier.

15.2 MATERIALS

15.2.1 Cement

All cement used in normal class concrete shall comply with AS 3972.

15.2.2 Supplementary Cementitious Materials

All supplementary cementitious materials used in normal class concrete shall comply with their relevant standards:

- *Fly ash shall comply with the requirements of AS 3582.1;*
- *Ground Granulated Blast Furnace Slag shall comply with the requirements of AS 3582.2;*
- *Amorphous Silica shall comply with the requirements of AS 3582.3.*

15.2.3 Chemical Admixtures

Admixtures shall conform to the requirements of AS 1478 and shall be batched in accordance with AS 1379.

15.2.4 Concrete Aggregates

Concrete coarse and fine aggregates shall conform to AS 2758.1 and must satisfy the requirements for exposure class as specified for the concrete application.

15.2.5 Alkali Reactive Aggregates

Where an aggregate is identified as having potential for alkali-aggregate reaction (i.e. it is either reactive or slowly reactive) in accordance with AS 2758.1 treatment to control the effects shall be in accordance with SA HB 79.

15.2.6 Curing Compounds

Where a liquid membrane forming curing compound is used as the method of curing concrete it shall comply with the requirements of AS 3799 and its application rate will be as recommended by the Supplier. The construction contractor will also need to demonstrate that any curing method used will not damage the appearance or the function of the structure.

15.2.7 Other Methods of Curing Concrete

Where other methods of curing concrete are used (such as formwork retention, water sprays, wet hessian or impermeable sheet) the construction contractor must develop a method statement that supports the method is capable of remaining in place for the curing periods defined in Table XI.8 according to the concrete strength and durability class. The construction contractor will also need to demonstrate that any curing method used will not damage the

appearance of the concrete or the function of the surrounding structures during construction.

15.3 STORAGE OF MATERIALS

Materials shall be stored as detailed in section 8 of this document.

15.4 CONCRETE MIX DESIGNS

The Contractor shall recommend mix designs to the Specifier for all normal class concrete used in the project for the Specifier's approval. The Contractor shall ensure that the mix design is suitable for the particular application. Concrete slump shall be nominated by the Contractor as appropriate for the intended application.

15.5 BATCHING, MIXING AND TRANSPORT

Batching, supply and delivery of concrete shall comply with AS 1379.

15.6 ACCEPTANCE AND REJECTION OF PLASTIC CONCRETE

Refer to section 11 of this document.

15.7 ACCEPTANCE AND REJECTION OF HARDENED CONCRETE

Refer to sub-sections 9.3, 9.4, 9.6, 9.7, 9.8, 9.9 and 12 of this document.

15.8 DEFECTS AND RECTIFICATION

Refer to section 14 of this document.

15.9 FALSEWORK

Falsework shall conform to AS 3610.1. The design and erection of falsework, the method of founding or supporting the falsework and the time, order and manner of its release shall all require approval of the Specifier. The

Specifier's approval of the use of completed sections of the project as support structures for falsework shall in no way relieve the Contractor of any responsibility for the restoration or repair of any resulting damage caused by such use.

15.10 FORMWORK

All formwork shall be subject to inspection and approval by the Specifier. Formwork shall conform to AS 3610.1 and provide a surface Finish Class as noted on the drawings.

15.10.1 Supports (Bar-Chairs and Spacers)

All bar chairs and spacers shall comply with AS/NZS 2425.

15.11 PLACING AND COMPACTING CONCRETE

No concrete shall be placed in the project site until:

- a) The formwork and reinforcement have been inspected, and*
- b) All foreign material has been completely removed from the forms.*

Reference can be made to the Guide, Part V, Sections 12 and 13 for more information on placing and compaction. It is often assumed that the concrete placing sub-contractor knows how to meet the objectives of this specification, but it is useful to provide a summary of these requirements.

An example of wording this sub-section is in the following:

Concrete placing shall be carried out continuously between forms and/or construction joints and in such a manner that a plastic concrete face is maintained. Placing and compaction shall be carried out so that the finished concrete thickness, its surface shape and level shown on the drawings will be obtained within the specified tolerances.

Concrete shall be deposited using suitable conveyors, concrete pumping equipment, clean chutes, troughs, hoppers or pipes so as to require a minimum of handling and redistribution.

The concrete shall be placed so that its working face is normal to the direction of placing. It shall be in such a manner as to minimise segregation. Hand spreading of concrete in a slab shall be done with shovels, not rakes. Vibrators are to be used for compaction of concrete and shall not be used to spread concrete.

Horizontal elements shall be placed with concrete in layers not more than 300 mm thick for compaction. Compact the following layer into the previous layer before the previous layer has taken initial set. The interval between successive layers of concrete shall be limited to be less than the time taken for the initial set of the previous layer to occur in the ambient conditions.

Vertical elements shall be placed to limit the free fall of concrete to maximum of 2 m.

Concrete shall be compacted to achieve dense and durable concrete, to the levels and tolerances specified.

The Contractor shall ensure that the concrete placing sub-contractor has the correct number and type of compaction equipment (vibrators, vibrating screeds or other approved equipment) to complete the placement.

15.12 TOLERANCES

Specified dimensional and surface tolerances for concrete should realistically reflect the requirements for the appearance and function of the concrete element. The practice of specifying more stringent tolerances than required to cover unforeseen circumstances should be avoided. The more stringent the tolerances, the more sophisticated (and therefore costly) are the construction and measurement methods needed to achieve and check them.

The following design standards for concrete structures can potentially be able to utilise normal class concrete:

- AS 3600 – Concrete Structures;
- AS 2870 – Residential Slabs and Footings;

- AS 3850.2 – Prefabricated concrete elements – Part 2: Building Construction.

Other concrete design standards, by virtue of their specified properties required of concrete, will automatically require special class concrete (refer to sub-section 16.7).

In AS 3600 and AS 2870, the tolerance requirements are as detailed in AS 3600 section 17 as well as the requirements of the formwork standard AS 3610.1. In addition to these standards, the CCAA Data sheet 'Tolerances for Concrete Surfaces' provides useful guidance on specifying tolerances.

An example of simple wording for this clause is given in the following:

Construct formwork so that finished concrete dimensional tolerances of the cast concrete element conform to requirements of AS 3600 and AS 3610.1.

15.13 FINISHING OF CONCRETE

All unformed surfaces must be finished to line and level as indicated on the drawings and within the tolerances specified.

All finishing operations must be completed prior to the application of any curing. The finishing operations will be carried out in a manner so as to provide a dense surface free from non-conforming surface cracking.

15.13.1 Prevention of Cracking

The concrete placing sub-contractor will need to plan and control the placing, compacting, curing and finishing operations to prevent cracking in the various concrete elements. In the case of slab placement or foundations with large exposed surface areas, it is recommended that evaporation retardants are applied to the levelled exposed surface as detailed in sub-sections 13.2.1 and 13.2.2.

The specification must make this requirement clear to the concrete placing sub-contractor. An example of wording this sub-section is in the following:

The concrete placing sub-contractor shall plan and control the placing, compacting, curing and

finishing operations to prevent cracking in the various concrete elements. In the case of slab placement or foundations with large exposed surface areas, an evaporation retardant shall be applied to the levelled, exposed surface when ambient conditions require this protection as detailed in sub-sections 13.2.1 and 13.2.2 of this specification.

15.13.2 Finish Type

The type and quality of concrete surface finish should generally be detailed on the drawings.

An example of wording this sub-section is in the following:

The concrete finish type and quality applicable to exposed surfaces and off-form finish shall be as specified on the drawings.

15.14 CURING OF CONCRETE

An example of wording this sub-section is in the following:

All concrete shall be cured in accordance with a suitable method as detailed in sub-section 13.4. The selected method for each concrete element shall be detailed in a work method statement by the Construction Contractor and submitted to the Specifier for approval prior to application.

15.15 EARLY LOADING

An example of wording this sub-section is in the following:

No loads including loads from backfilling shall be placed on the concrete structure for at least seven days after placement of concrete and until testing indicates that the required strength of the concrete has been achieved and approved by the Design Engineer.

15.16 REMOVAL OF FORMWORK

Forms, falsework and centring should remain in position until the times stated in AS 3600 clause 17.6 have elapsed after completion of concreting.

In addition, the curing requirements of AS 3600 clauses 4.4 and 4.5 should be considered before stripping the forms. If forms have to be stripped under 7 days then an appropriate curing method will be applied to the stripped surface within an hour of stripping.

Forms should be removed with care, without hammering and wedging, and in a manner which will not injure the concrete or disturb the remaining supports.

15.17 SURFACE TREATMENT OF CONCRETE

Prior to commencing concreting operations, the Contractor should document procedures and standards for surface dressing and repair of concrete. These procedures should be subject to the approval of the Specifier.

Concrete surfaces should be free of honeycombing and pockets and free of voids larger than 20 mm in lateral dimensions or greater than 3 mm depth from the surrounding surface.

The repair material should also be approved by the specifier.

15.17.1 Formed Surfaces Exposed to View

Following the removal of formwork, the following operations should be carried out to the standard approved by the Specifier:

- Unwanted projections shall be ground off or removed to provide a smooth surface;
- Where specified in the Drawings, surfaces shall achieve the required surface finish to AS 3610.1;
- Where surface finish is not specified in the Drawings, a default class of surface finish to AS 3610.1 is required to be nominated in this specification (e.g. Class 2).

15.18 CONSTRUCTION, ISOLATION, EXPANSION AND CONTRACTION JOINTS

All planned joints should be marked on the project drawings along with specific details of

their construction and relationship to the continuity or otherwise of reinforcement through the joint.

The location of unplanned joints should be approved by the Contractor and Specifier.

Further details on the various types of joints are provided in the Guide, Part V, Section 17.

15.18.1 Construction Joints

Construction joints should be on a single plane and at right angles to the main reinforcement. They should preferably be vertical or horizontal to the member.

In jointed pavement construction, unplanned joints should be constructed at the planned location of contraction or isolation joints. For pavements, the proper location of construction joints is critical to the functioning of the pavement. The Specifier should be consulted before giving any approval to the relocation of construction joints or the inclusion of additional ones.

AS 3600 requires that in columns and walls a construction joint be formed logically at the soffit of the beams and slabs they support.

During placement the concrete adjacent to the joint should be well compacted. The joint should be stripped when the concrete has set and hosed down to expose the coarse aggregate to aid the shear connection across the joint. Any problems in stripping of the joint will be eased if it is located away from regions of high moment and reinforcement congestion.

An example of wording is in the following:

Construction joints shall be located as documented. Joints shall not change the requirement for the concrete surface to achieve specified tolerances.

If a delay in concrete supply to a continuous pour occurs and the previous concrete has started setting at the point of commencing the pour, then a construction joint shall be formed at that point. Prior to recommencement of placement the surface of the placed concrete will be roughened at the construction joint to a pronounced profile with a surface roughness not less than 3 mm. Remove loose aggregate particles and laitance. Saturate the concrete

surface then remove all excess water prior to placing the adjoining concrete. Where applicable, provide temporary openings in formwork to allow contaminated water to be removed.

15.18.2 Isolation and Expansion Joints

An example of wording this sub-section is in the following:

Isolation joints shall be formed about structures and features that project through, into or against the base, using joint filler of the type, thickness and width as indicated, and installed in such a manner as to form a complete, uniform separation.

Isolation joints shall be formed by means of an approved preformed filler material which shall be installed only after the concrete on one face of the joint has hardened. The strips of filler shall be fitted tightly together, attached to the hardened concrete with approved adhesive, and held in line to ensure continuity and prevent any concrete from entering the joint.

Expansion joints shall be provided as detailed on the drawings.

Isolation and expansion joints shall be sealed along the top surface and any exposed sides.

15.18.3 Contraction Joints

Transverse contraction joints are constructed as either tooled joints, wherein a groove is formed in the plastic concrete, or sawn joints, wherein a groove is sawn in the hardened concrete, or an approved regular combination of the two.

An example of wording for a sawn joint is in the following:

Sawn contraction joints shall be constructed by sawing a groove not less than 3 mm and not more than 5 mm in width for the entire depth of the cut. The depth of the cut shall be between one-quarter and one-third of the base depth unless otherwise indicated in the drawings.

Sawing of the joints shall commence as early as possible and be carried out when the concrete has hardened sufficiently to permit cutting without excessive chipping, spalling or tearing.

A chalk line or other suitable guide shall be used to mark the alignment of the joint. The saw cut shall be straight from edge to edge of the panels and shall not vary more than 15 mm from the true joint alignment.

Before sawing a joint, the concrete shall be examined closely for any cracking; the joint shall not be sawn if a crack has occurred near the location chosen for a joint. In these instances, the proposed joint shall be relocated away from the crack and remedial treatment may be required. Sawing shall be discontinued if a crack develops ahead of the saw cut.

16. SPECIAL CLASS CONCRETE FOR IN-SITU APPLICATIONS

This section applies to cast in-situ concrete elements, where the drawings require special class concrete. Special class concrete is defined in AS 1379. The need for special class concrete will largely be dependent on the type of structure that the concrete is used in and the environment that the concrete structure is located in. A number of Australian concrete structural design Standards or Guidelines describe concrete requirements where it is likely that special class concrete will be required due to the mix design requirements or special properties being nominated. These include:

- AS 3600 for exposure classifications B2, C1 and C2;
- AS 3850.2 for required early strength outside of AS 1379 normal class requirements in precast concrete;
- AS 2159 for particular requirements relating to piling mix properties;
- AS 3735 for special shrinkage, binder and W/B ratio requirements for water retaining structures;
- AS 4997 for special shrinkage, binder and W/B ratio requirements for structures in a maritime environment.

16.1 MIX DESIGNS

Each special class mix to be utilised in a construction project must be itemised along with any special requirements for the mix, its testing and its constituent materials. A useful

method of presenting this is to set up a schedule of all special class mixes (refer to sub-section 16.1.1).

An example of wording for this sub-section is as follows:

The Contractor shall recommend mix designs to the Specifier for all special class concrete used in the project for the Specifier's approval. The Contractor shall ensure that the mix design is suitable for the particular application and that required trial mixes have been carried out and reported to the Specifier. Concrete slump shall be nominated by the Contractor as appropriate for the intended application.

16.1.1 Special Mix Schedule

It is useful to summarise the special class concrete mixes along with their special requirements in the specification so that the users of the specification can verify that all of the requirements have been understood and that a common designation for each mix can be introduced to assist quality assurance requirements.

One method to achieve this is to develop a Special Class Concrete Mix Schedule that is part of the concrete specification. An example of such a schedule is given in **Table XI.9**.

16.1.2 Trial Mixes

Where extensive performance data is not available regarding a concrete mix, mix design acceptance will be on the basis of trial mixes.

'Extensive performance data' refers to test results for the proposed or similar mixes over a recent timeframe. Trial mixes will be made using all constituent materials proposed for the project. The trial mix may be carried out in a NATA-certified laboratory or through the intended concrete plant for the project. When using a batch of concrete from the concrete plant for a trial, the minimum volume of the trial mix should not be less than 25% of the rated capacity of the mixer. Note that higher volumes of trial mix may be required depending on the range of testing to be conducted.

Trial mixes shall be batched using the nominated mix design including compliance with any specified plastic properties or maximum water content allowable (unless

slump or other consistency limits are exceeded).

Each trial mix shall be tested for slump or spread, plastic unit weight (yield), air content and strength as well as any specialist testing required by this specification.

When supplying a trial mix from the proposed concrete plant, the trial mix will be batched and delivered in a manner as per the anticipated final procedures used, including any admixtures added on site.

Table XI.9 – Example of a Special Class Concrete Mix Schedule

Mix Designation	Standard/ Design Life (Yrs)	Minimum Binder Content (kg/m³)	Max. W/B Ratio / Binder Composition	Special Testing Requirement	Frequency of Special Testing
S40/20/200/Piling	AS 2159 / 100	-	-	See Note 2	Trial mix only
SB40/20/100/P	AS 3600 / 50	-	- / >25% Fly ash	ASTM C1556 / <5.0×10 ⁻¹²	Trial mix only
SC50/20/100/P	AS 4997 / 100	450	0.40 / >25% Fly ash	AS1012.13 / See Note 1	Trial mix plus 1 sample per 1,000 m ³
S40/20/80/P – LH	AS 3600 / 50	400	0.45 / Type LH Cement	See Note 3	Trial mix only

NOTES:

- 1) Drying shrinkage testing at 56 days for SC50/20/100/P with compliance trial mix <560 μm; maximum individual sample value <600 μm and the average of 5 consecutive samples <585 μm;
- 2) Concrete for piles will be S40/20/200/Piling and shall be suitable to be placed by tremie with a target slump of 200 mm and the trial mix shall be tested for Bauer Filtration to 'EFFC/DFI Task Group' test method. Maximum value <23 mL;
- 3) The trial mix concrete mix S40/20/80/P – Type LH used in mass foundations will be tested for semi-adiabatic temperature rise using test method from CIRIA C660 '1 m³ Hot box test'. The maximum temperature rise from the target initial temperature of the concrete mix shall be less than 32°C and the target initial concrete temperature shall not exceed 28°C.

The slump or slump spread measured shall be within tolerance (see Tables XI.6 and XI.7). At least two cylinders will be cast from each trial mix for compressive strength testing at 28 days and additional cylinders (a minimum of two per age and at least 7 days must be assessed) shall be required if strength gain is to be assessed for early stripping or loading.

Timing of trial mixes for acceptance of mix designs will always be a consideration as part of the project critical path (milestones) as some testing can take up to 12 months from the trial mix to complete and at least three months for early indication of the likelihood of conformance.

Conformance of trial mix hardened properties needs careful consideration due to the risks associated with limited data. In the case of compressive strength, it is useful to ensure that the trial mix strength is equal to or greater than the intended target strength of the mix at 28 days. For other tests, the specifier will need to use judgement as to conformance of a single trial mix while taking account of the likely test value variability.

16.2 MATERIALS

Materials for special class concrete are generally specified in the same manner as is given in sub-section 15.2. It is possible that special materials or more restricted materials

may be required in the case of special class concrete.

16.2.1 Special Materials

More restrictions may apply to certain special class concrete materials. For example:

- A particular type or source of cement (e.g. Types SR, SL, LH, HE could be chosen specifically from those covered by AS 3972) or can be White or Off-White cement;
- Stronger limitations on the maximum or minimum proportions of various SCM's may be applicable for certain mixes or all special class mixes;
- Aggregates may have further restrictions or test types and/or conformance requirements that are outside those of AS 2758.1 for a particular concrete mix;
- Requirements (e.g. fire resistance properties, exclusion of particular mineral compositions etc.);
- Water requirements may be different to AS 1379 with lower levels of certain chemical components;
- Admixtures or additives that are allowed to be used may be more limited than those allowed by AS 1478.1 or may be restricted to one or a few admixture types or sources.

Where possible, these restrictions are best noted in the special mix schedule.

16.3 TESTING PROCEDURES

An example of wording for this sub-section is in the following:

Sampling, testing and acceptance of concrete for in-situ placement shall be undertaken in accordance with sections 9, 11 and 12 unless stated otherwise in this sub-section.

In some cases, there is a need to clarify the methods of more specialised tests or alternative acceptance criteria for the standard tests. Where possible, test methods, the mix designations that they apply to and the testing frequency are best summarised in this sub-section in a table form and referenced by this sub-section number and table number in the 'special class concrete mix schedule'.

An example of this is provided in **Table XI.10**.

16.3.1 Early Stripping

Where early stripping of concrete formwork is required refer to sub-sections 15.15 and 15.16 in this document.

16.3.2 Early Loading

If concrete is to be placed over or adjacent to and connected with a previous section prior to 28-day testing and acceptance, additional sampling and early age testing shall be undertaken for verification of structural adequacy by the Design Engineer prior to loading the previous section.

Table XI.10 – Special Concrete Testing Schedule

Mix Designation	Test Method	Test Standard	Compliance Criteria	Frequency of Special Testing
S40/20/200/Piling	Bauer Filtration	EFFC/DFI Task Group	Maximum value <23 mL	Trial mix only
SB40/20/100/P	56-day Chloride diffusion coefficient	ASTM C1556	<5.0×10 ⁻¹²	Trial mix only
SC50/20/100/P	Drying Shrinkage	AS 1012.13	Average of 5 consecutive samples <585 μm	1 sample per 1,000 m ³
S40/20/80/P – LH	Semi-adiabatic temperature rise	CIRIA C660	<32°C	Trial mix only

16.4 FALSEWORK

Refer to sub-section 15.9

16.5 FORMWORK

Refer to sub-section 15.10.

16.5.1 Supports (bar-chairs and spacers)

Refer to sub-section 15.10.1.

16.6 CONCRETE TEMPERATURE

The requirements for the temperature on delivery of normal class concrete are provided in sub-section 13.1. In some special class concrete and particularly in concrete that is placed at a thickness of 500 mm or greater and has higher strength requirements, the maximum temperature that the concrete reaches in its forms may need to be accounted for. This may be achieved through a number of methods including:

- Reducing the maximum allowable temperature of concrete as delivered to the site;
- Modifying the mix constituents to control the temperature rise in forms;
- Designing higher reinforcement ratios in the structure where there is a concern about cracking;
- A combination of all these methods to control the risks that have been identified (e.g. cracking due to thermal movement or the risk of Delayed Ettringite Formation or “DEF”).

The specification of control measures will depend on the structural element dimensions as well as the combination of exposures related to the element.

16.7 PLACING AND COMPACTION OF CONCRETE

Where the consistency of the plastic concrete is as per normal class concrete then reference should be made to sub-section 15.11. Where the specified consistency of the special class concrete is outside of this range (such as roller-compacted concrete, low slump paving

machine concrete at the lower end of consistency or Super-workable concrete at the higher end of consistency), the placing and compaction methods intended must be specified (type of placing equipment and method of compaction (if any)).

16.7.1 Placing Under Water

A common method of placing concrete under water (e.g. wet piles) is to use a tremie tube delivery. More information on this method is available in the Guide, Part VI, Section 21. In general, the concrete mix used in this method of delivery will require specialist design and the placing procedure needs to be proposed by the Construction Contractor. An example of wording for this sub-section is in the following:

The Contractor shall submit a procedure for underwater concreting to the Specifier which includes placement of concrete in wet cast-in-place piles using a tremie tube method.

16.8 TOLERANCES

Refer to sub-section 15.12.

16.9 REMOVAL OF FORMWORK

Refer to sub-section 15.16.

16.10 SURFACE TREATMENT OF CONCRETE

Refer to sub-section 15.17.

16.11 FINISHING OF CONCRETE

Refer to sub-section 15.13.

16.12 CURING OF CONCRETE

Refer to sub-section 15.14.

16.13 CONSTRUCTION, ISOLATION, EXPANSION AND CONTRACTION JOINTS

Refer to sub-section 15.18.

16.13.1 Construction Joints in Marine or Other Aggressive Environments

An aggressive environment such as the spray zone or splash/tidal zone in AS 3600 requires special class concrete and will require a suitable procedure for forming a construction joint. An example of wording for this sub-section is in the following:

Construction joints in AS 3600 exposure class C1 or C2, environments shall be prepared as follows:

- 1) *The surface of the joint shall be prepared as in sub-section 15.18.1 immediately prior to casting concrete against the joint. The surface and any projecting steel shall then be washed with clean fresh water to remove any salt deposits or other contaminants, and either blown dry with oil-free air or allowed to dry while protected from further contamination;*
- 2) *The concrete surface shall be coated with a wet-to-dry epoxy resin, as approved by the Specifier, followed by placement of the fresh concrete before the epoxy on the interface has hardened.*

17 SPECIAL CLASS CONCRETE FOR PRECAST AND PRECAST-PRESTRESSED APPLICATIONS

This section applies to precast and precast-prestressed concrete elements, where the drawings require special class concrete. Special class concrete is defined in AS 1379.

17.1 MIX DESIGNS

Each special class mix to be utilised in a construction project must be itemised along with any special requirements for the mix, its testing and its constituent materials. A useful method of presenting this is to set up a schedule of all special class mixes (refer to sub-section 16.1.1).

The Contractor shall recommend mix designs to the Specifier for all special class concrete used in the project for the Specifier's approval.

The Contractor shall ensure that the mix design is suitable for the particular application and that required trial mixes have been carried out and reported to the Specifier. Concrete slump shall be nominated by the Contractor as appropriate for the intended application.

17.1.1 Special Mix Schedule

Refer to sub-section 16.1.1.

17.1.2 Trial Mixes

Refer to sub-section 16.1.2.

17.2 MATERIALS

Materials for special class concrete are generally specified in the same manner as is given in sub-section 15.2. It is possible that special materials or more restricted materials may be required in the case of special class concrete.

17.2.1 Special Materials

More restrictions may apply to certain special class concrete materials when used in pre-cast concrete applications. It is common that high early strength is required from the concrete so that better mould or formwork utilisation can be achieved, for example:

- A particular type or source of cement (e.g. Type GP or Type HE cement could be chosen specifically from those covered by AS 3972) or can be White or Off-White cement for decorative/colour reasons;
- Stronger limitations on the maximum proportions of various SCM's may be applicable to achieve higher early strength;
- Aggregates may have further restrictions or test types and/or conformance requirements that are outside those of AS 2758.1 for particular concrete mix requirements (e.g. fire resistance properties or ruling out aggregates with potential for ASR due to the use of accelerated curing and lower SCM proportions);
- Water requirements may be different to AS 1379 with lower levels of certain chemical components;
- Admixtures or additives that are allowed

to be used may be more limited than those allowed by AS 1478.1 or may be restricted to one or a few admixture types or sources.

Where possible, these restrictions are best noted in the special mix schedule.

17.3 TESTING PROCEDURES

An example of wording for this sub-section is in the following:

Sampling, testing and acceptance of concrete for in-situ placement shall be undertaken in

accordance with sections 9, 11 and 12 unless stated otherwise in this sub-section.

In some cases, there is a need to clarify the methods of more specialised tests or alternative acceptance criteria for the standard tests. Where possible, test methods, the mix designations that they apply to and the testing frequency is best summarised in this sub-section in a table form and referenced by this sub-section number and table number in the 'special class concrete mix schedule'.

An example of this is provided in **Table XI.11**.

Table XI.11 – Special Concrete Testing Schedule

Mix Designation	Test Method	Test Standard	Compliance Criteria	Frequency of Special Testing
S40/20/80/HAC	Compressive Strength	AS 1012.8.1 and AS 1012.9, See Note 1	See Note 1	1 per 25 m ³ minimum 3 samples per day of production
SC50/20/120/HES	Compressive Strength	AS 1012.8.1 and AS 1012.9	See Note 2	1 per 50 m ³

NOTES:

- 1) Concrete mix S40/20/80/HAC will be cured by heat accelerated curing. Standard concrete sampling and testing in accordance with AS 1012.8.1 and AS 1012.9. Curing of test specimens will be as for the precast segment curing using Heat Accelerated Curing for the first 16 hours followed by cooling and standard curing thereafter. The 24-hour strength assessed by the average of 3 consecutive samples shall exceed 35 MPa and no single sample strength shall be less than 30 MPa. Test samples assessed at 28 days shall comply with the requirements of AS 1379 for the specified characteristic strength (40 MPa);
- 2) Concrete mix SC50/20/120/HES will be cured in ambient conditions. Standard concrete sampling and testing in accordance with AS 1012.8.1 and AS 1012.9. The 3-day strength assessed by the average of 3 consecutive samples shall exceed 25 MPa for demoulding. Test samples assessed at 28 days shall comply with the requirements of AS 1379 for the specified characteristic strength (50 MPa).

17.4 CONCRETE TEMPERATURE

The requirements for the temperature on delivery of normal class concrete are provided in sub-section 13.1. In some special class precast concrete and particularly in concrete that is placed at a thickness of 500 mm or greater and has higher strength requirements, the maximum temperature that the concrete reaches in its forms may need to be assessed to ensure the concrete temperature does not exceed the specified maximum. The maximum allowable temperature will depend in the binder composition and reinforcement ratios in most cases (refer to sub-section 16.6).

17.5 PLACING AND COMPACTING CONCRETE

The method of compaction will need to be specified to suit the consistency of the specified mix, type of forms or moulds used and accessibility for vibrators around the reinforcement. In some cases, form vibration may be a suitable method. In all cases, the compaction must be sufficient to produce an adequate consolidation of the concrete as well as the specified surface finish.

17.6 DIMENSIONAL TOLERANCES

Dimensional tolerances shall be in accordance with AS 3850.2.

17.7 REMOVAL OF FORMS OR DEMOULDING

Removal of forms or moulds shall only take place where the concrete strength is demonstrated to have achieved the minimum average strength required by the Design Engineer.

17.8 SURFACE TREATMENT OF CONCRETE

Refer to sub-section 15.17 in this document.

17.9 CURING OF CONCRETE

Refer to sub-section 13.4 for ambient curing of precast concrete. For Heat Accelerated Curing refer to the Guide, Part V, Section 15.

17.9.1 Heat Accelerated Curing (HAC)

Heat accelerated curing can be carried out using either steam or hot water curing methods.

Steam curing of precast and precast prestressed concrete units should be carried out within an appropriately designed enclosure. The formwork, enclosure and steam lines shall be arranged so that the temperature distribution around the units being cured is uniform. The temperature variation between any two enclosure locations needs to be monitored and controlled within specified limits.

Steam curing of precast and precast prestressed concrete units should be carried out within an appropriately designed enclosure. The formwork, enclosure and steam lines shall be arranged so that the temperature distribution around the units being cured is uniform. The temperature variation between any two enclosure locations needs to be monitored and controlled within specified limits.

Hot water curing of precast and precast prestressed concrete units can be carried out

within a steel mould fitted with hot water piping that transfers the heat from the hot water uniformly to the steel mould and the concrete. The difference between the inlet temperature and the outlet temperature of the hot water curing system needs to be monitored and controlled. The free concrete surface of the units being cured should ensure that the minimum average relative humidity in the enclosure shall be maintained at 90% and that the free surface temperature is within specified limits of the maximum concrete temperature in the mould at any time during the curing process.

The maximum surface temperature of concrete within the enclosure (steam curing), or the maximum water temperature (hot water curing) should not exceed 70°C. The maximum temperature at any point within the concrete shall not exceed 75°C at any point during or after the heating or curing process. This temperature may be reduced where concern exists for a particular cement combination in regard to delayed ettringite formation ('DEF').

In general, the HAC cycle will involve four stages:

- Pre-set or delay period at ambient temperature prior to heating;
- The heating period (at a controlled rate of temperature rise);
- Curing period during which the maximum temperature is reached and maintained;
- Cooling period prior to form or mould removal (at a controlled rate of temperature drop to avoid too large a temperature gradient inside the concrete element leading to cracking).

The complete HAC process typically will take at least 16 hours but may vary. The precast sub-contractor should provide the Contractor and Specifier with details of the intended curing process including the target temperature against time for each stage of the cycle, control limits and details of temperature monitoring points. Records should be kept of the cycle for each precast element with compliance for temperature variances across all monitoring points.

18 REFERENCES

18.1 AUSTRALIAN STANDARDS

- 1) AS 1012 – *Methods of testing concrete*
- 2) AS 1141 – *Methods for sampling and testing aggregates*
- 3) AS 1379 – *Specification and supply of concrete*
- 4) AS 1478.1 – *Chemical admixtures for concrete*
- 5) AS 2159 – *Piling – Design and installation*
- 6) AS/NZS 2425 – *Bar chairs in reinforced concrete*
- 7) AS 2758.1 – *Part 1: Concrete aggregates*
- 8) AS 2870 – *Residential slabs and footings*
- 9) AS/NZS 3582 – *Supplementary cementitious materials (Parts 1 to 3)*
- 10) AS 3600 – *Concrete Structures*
- 11) AS 3610.1 – *Formwork for Concrete: Part 1, Specifications*
- 12) AS 3735 – *Concrete structures retaining liquids*
- 13) AS 3799 – *Liquid membrane-forming curing compounds for concrete*
- 14) AS 3850.2 – *Prefabricated concrete elements*
- 15) AS 3972 – *General purpose and blended cements*
- 16) AS 4997 – *Guidelines for the design of maritime structures*
- 17) AS 5100.5 – *Bridge design, Part 5: Concrete*
- 18) AS HB 79 – *Alkali Aggregate reaction – Guidelines on Minimising the Risk of Damage to Concrete Structures in Australia*
- 4) ASTM C 1399 – *Standard Test Method for Obtaining Average Residual-Strength of Fiber-Reinforced Concrete*
- 5) ASTM C 1556 – *Standard Test Method for Determining the Apparent Chloride Diffusion Coefficient of Cementitious Mixtures by Bulk Diffusion*
- 6) ASTM C 1609 – *Standard Test Method for Flexural Performance of Fiber-Reinforced Concrete (Using Beam with Third-Point Loading)*
- 7) ASTM C 1611 – *Standard Test Method for Slump Flow of Self-Consolidating Concrete*
- 8) EN 14651 – *Test method for metallic fibre concrete. Measuring the flexural tensile strength (limit of proportionality (LOP), residual)*

18.3 GENERAL REFERENCE DOCUMENTS

- 1) CIRIA C660 'Early-age Thermal Crack Control in Concrete' (P B Bamforth)
- 2) EFFC/DFI 'Best Practice Guide to Tremie Concrete for Deep Foundations' (EFFC/DFI Task Group)

18.2 INTERNATIONAL STANDARDS

- 1) ACI 117 – *Specification for Tolerances for Concrete Construction and Materials*
- 2) ACI 305 – *Guide to Hot Weather Concreting*
- 3) ASTM C 171 – *Standard Specification for Sheet Materials for Curing Concrete*

GUIDE TO CONCRETE CONSTRUCTION

T41



CEMENT CONCRETE
& AGGREGATES AUSTRALIA

GLOSSARY

This document provides a list of technical terms popularly used in the field of cement, concrete and aggregate – accompanied by a brief definition for each of them. Interested readers may find it useful for a quick referencing in their everyday practice, as well as for self-learning purposes. Readers are also encouraged to follow the supplied indexes to locate the exact sections/sub-sections in the Guide where the terms are discussed in detail. To use the indexes:

- For composite parts of the Guide with lower individual sections (i.e. Part II, Parts IV to IX), indexes are composed using part, section and sub-section hierarchy. An illustration is given below for Part II-Section 3, Sub-section 5.3 of the Guide:

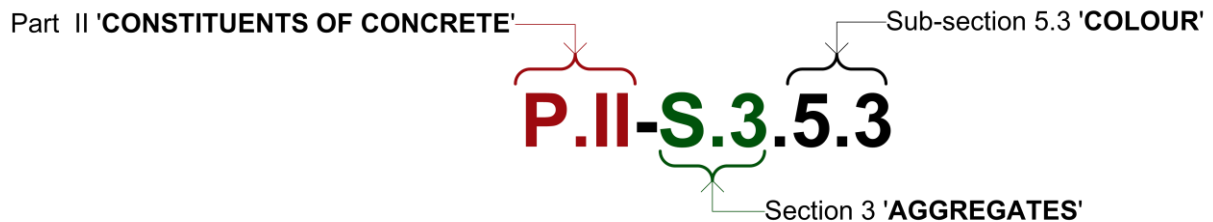

- For standalone parts with no lower individual sections (i.e. Introduction, Parts I, III, X and XI), indexes are simplified to the following form (example given for Part III, Sub-section 2.9 of the Guide):



A

<p>Abrasion Resistance</p> <p>The abrasion resistance of concrete is important in many applications (e.g. driveways, industrial floors) and is a function primarily of compressive strength. To improve abrasion resistance, proprietary topping mixes or shakes may be used on the concrete surface or steel fibres may be included in the concrete mix.</p>	<p>P.VIII-S.25.3.2</p>
<p>Admixtures</p> <p>Admixtures are defined in AS 1478 as 'a material, other than water, aggregate and cementitious materials, used as an ingredient of concrete, and added to the batch in controlled amounts immediately before or during its mixing to produce some desired modification to the properties of the concrete'. There are a number of admixture types – the main ones are described below.</p>	<p>P.II-S.5.2.1</p> <p>P.XI.7.4</p>

<p><i>Air-entraining (Type AEA)</i></p> <p>These admixtures are used to purposefully entrain air in concrete. Entrained air assists in (a) preventing Freeze-Thaw damage in concrete exposed to repeated freezing and thawing and (b) increasing the cohesiveness of concrete (particularly lower concrete grades) which assists in improving workability and pumpability.</p> <p><i>Retarder (Type Re)</i></p> <p>Retarders slow the rate of cement hydration and are useful when concrete has to be transported and placed and finished in hot weather conditions. The retarder extends setting times and provides more time for handling and managing the concrete.</p> <p><i>Accelerator (Type Ac)</i></p> <p>Accelerators increase the rate of cement hydration and are useful in cold weather conditions to reduce the time taken for concrete to set and for finishing to be completed.</p> <p><i>Water Reducer (Types WR, MWR, HRWR)</i></p> <p>Water reducers (WR) are able to reduce the total water demand of a concrete mix while retaining required levels of workability. There are three grades of WR – namely ‘normal’, ‘medium’ and ‘high range’ (also known as superplasticisers) water reducers – and these can reduce total water by up to 10%, 15% and 25% respectively. WR can also improve mix economy by allowing a lower W/C ratio to be used and still achieve required concrete workability.</p> <p>See also <i>Superplasticiser</i> and <i>Water Reducer</i>.</p> <p><i>Other Admixtures</i></p> <p>Other admixture types that are less commonly used include Shrinkage Reducing Admixtures; Corrosion Inhibitors; Hydration Control (Type HCA); Anti-Washout (Type AWA); Permeability Reducing; Internal Curing; Anti-Freeze; and Foaming.</p> <p>See also ‘<i>Water-proofing</i>’ <i>Concrete Additive / Admixture</i>.</p>	<p>P.II-S.5.2.2</p> <p>P.II-S.5.2.3</p> <p>P.II-S.5.2.3</p> <p>P.II-S.5.2.4</p> <p>P.II-S.5.2.5</p>
<p>Admixture Overdose</p> <p>Admixtures are quite powerful chemicals and their misuse can cause significant concrete problems. An overdose of a retarding admixture can cause large delays to concrete setting time and hence to finishing time, while an overdose of accelerator can cause premature stiffening and serious issues in finishing the concrete. An overdose of air-entraining admixtures can cause significant issues with concrete strength.</p>	<p>P.II-S.5.6</p>
<p>Aggregates</p> <p>Aggregates are most broadly defined as ‘Coarse’ and ‘Fine’, with the cut-off size between the two groups being 4.75 mm. Aggregates make up about 75% of the volume of concrete and contribute substantially to all aspects of concrete performance. ‘Coarse’ aggregates may be either crushed rock, gravel or screenings. ‘Fine’ aggregates include both natural sands and crusher fines. Important aggregate properties include maximum size, individual and combined gradings, shape and texture, strength, durability and chemical resistance.</p> <p>Aggregate requirements for concrete are defined in AS 2758.1.</p>	<p>P.II-S.3</p> <p>P.XI.7.5</p>

<p>Aggregate Grading</p> <p>Grading refers to the determination of the particle-size distribution for aggregate. Grading limits and maximum aggregate size are specified because these properties affect the amount of aggregate used as well as cement and water requirements, workability, pumpability, and durability of concrete.</p>	<p>P.II-S.3</p>
<p>Agitator</p> <p>An ‘agitator’ is a concrete truck. In their earliest forms, these trucks were literally agitators into which plastic concrete mixed in a wet-batch plant was loaded. These trucks then agitated the concrete while it was delivered from the plant to job site – the agitation keeping the concrete ‘live’. Colloquially, the term agitator is now used for ‘transit mixers’ in which concrete, having been batched into the bowl of the truck as dry materials, is mixed prior to delivery to the job site.</p>	<p>P.IV-S.9.2.5 P.IV-S.10.2</p>
<p>Air Content (of concrete)</p> <p>All concrete contains some air trapped in its matrix. There are two forms of this air:</p> <p><i>Entrapped air</i></p> <p>Entrapped air is generally larger voids formed during mixing, these are largely removed during compaction processes (e.g. vibration of the concrete).</p> <p><i>Entrained air</i></p> <p>Entrained air is generally a finer matrix of air voids that are deliberately created by certain types of admixtures including air entraining agents (AEA) and some other surfactant admixtures, these are designed to be more resistant to compaction and should not be removed in well-designed concrete.</p> <p>See also <i>Admixtures</i>.</p>	<p>P.XI.9.2 P.V-S.13 P.II-S.5.2.2</p>
<p>Alkali Activated Materials (AAM’s)</p> <p>Alkali activated binders have been the focus of research for decades, with Glukhovsky in the 1950’s and Davidovits in the 1970’s being two of the main proponents. Alkali activated slags were widely used in Eastern Europe when there were cement shortages, and more recently research into AAM’s has been motivated by trying to find low-carbon alternatives to Portland cement. Australia is a leading force in both research and application of AAM’s.</p>	<p>P.VII-S.23.3</p>
<p>Alkali-Aggregate Reaction (AAR)</p> <p>Chemical reaction in either mortar or concrete between alkalis (sodium and potassium) from Portland cement or other sources and certain constituents of some aggregates. The reaction products when combined with water can cause expansion and cracking in concrete containing the aggregates. Two major types of AAR are:</p> <p><i>Alkali-Silica Reaction (ASR)</i></p> <p>The reaction between the alkalis (sodium and potassium) in Portland cement and certain siliceous rocks or minerals, such as opaline chert, strained quartz, and acidic volcanic glass, present in some aggregates.</p> <p><i>Alkali-Carbonate Reaction (ACR)</i></p> <p>ACR is the reaction between certain dolomitic limestone and alkalis in the pore solution of the concrete. It is rare in Australia.</p>	<p>P.II-S.3.4.6</p>

<p>Alkalinity</p> <p>Hydrated cement paste is strongly alkaline, with a pH of about 12.5, due significantly to the presence of the hydration product calcium hydroxide or 'lime'. This alkalinity is important in passivating the surface of any embedded steel. Reduction in paste alkalinity and pH (e.g. by reaction with CO₂) may lead to steel corrosion.</p>	<p>P.II-S.1.4.6</p> <p>P.II-S.4.3.3</p>
<p>Anchorage</p> <p>(1) In post-tensioning, a device used to anchor the tendon to the concrete member;</p> <p>(2) In pretensioning, a device used to maintain the elongation of a tendon during the time interval between stressing and release;</p> <p>(3) In precast-concrete construction, the devices for attaching precast units to the building frame;</p> <p>(4) In slab or wall construction, the device used to anchor the slab or wall to the foundation, rock, or adjacent structure.</p>	<p>P.V-S.11.5</p> <p>P.V-S.11.6</p> <p>P.V-S.11.7</p>
<p>Agitator Truck</p> <p>'Agitator' is the colloquial term for 'transit mixer' – the vehicles that are loaded with concrete raw materials at a dry-batch plant and in which the concrete mixing takes place. These vehicles then also transfer the plastic concrete to the job site and discharge it into the forms or into a concrete pump or some other receiving (and distribution) device.</p> <p>See also <i>Agitator</i>.</p>	<p>P.IV-S.9.2.5</p> <p>P.IV-S.10.2</p>
<p>Alternative Binder</p> <p>An 'alternative binder' is a binder used in the manufacture of concrete that does not contain Portland Cement. Examples of these materials are <i>Alkali Activated Materials</i> and <i>Geopolymers</i> that are defined in this Glossary. Research into alternative binders has been driven primarily by the need to reduce the levels of <i>Embodied CO₂</i> and <i>Embodied Energy</i> (see below) in concrete.</p>	<p>P.VII-S.23</p>
<p>Amorphous Silica</p> <p>Amorphous silicas are a group of SCM's that are defined in AS 3582.3. The most common is silica fume, but other forms of amorphous silica are also used – the use depending largely on availability. In New Zealand a naturally occurring material known as Microsilica has been used to improve concrete performance and mitigate AAR/ASR.</p> <p>See also <i>Silica Fume</i>.</p>	<p>P.II-S.2.8</p>
<p>Architectural Precast Concrete</p> <p>Precast concrete has been instrumental in changing the view that concrete is a 'simple grey monotone structure'. Through a wide range of innovations, precast concrete has transformed the architectural use of concrete for building facades, monumental structures, cityscapes and public spaces and in many other areas. The use of special finishes (e.g. exposed aggregate, acid etching), a wide range of colours and textures (e.g. by using form liners) have shown that concrete does not have to be boring and is able to be produced with vibrant decorative finishes.</p>	<p>P.VI-S.20.4</p>

<p>As Drawn Wire (mill coil)</p> <p>Wire drawing is a metalworking process used to reduce the cross-section of a wire by pulling the wire through a single, or series of, drawing die(s). This process is used to form wire strand, cables and prestress wire (refer to AS 4672.1).</p>	<p>P.II-S.6.3</p>
<p>AS 1379</p> <p>The Australian Standard for ‘Specification and supply of concrete’. AS 1379 covers concrete constituents, concrete plants/equipment, production and delivery, sampling and testing generally for concrete specified by compressive strength. Importantly, AS 1379 nominates coverage in terms of concrete grades (20-100 MPa) and classes – viz. ‘Normal Class’ and ‘Special Class’.</p>	<p>P.IV-S.8</p>
<p>AS 3600</p> <p>The Australian Standard for ‘Concrete Structures’. AS 3600 provides unified rules for the design and detailing of concrete structures and members – with or without reinforcing steel or prestressing tendons. The Standard also provides performance criteria against which a structure can be assessed for compliance with design requirements.</p>	<p>P.VIII-S.25</p>
<p>Australian Standards</p> <p>Australian Standards are a set of nationally recognised documents which, if followed, provide producers, users and the community with some confidence that certain levels of technical and safety performance have been met for products used in industry and domestically. These Standards are internationally recognised and provide confidence to investors and others about required levels of manufacturing quality and product performance.</p>	<p>P.XI.1.2</p>
<p>Autoclaving</p> <p>Autoclaving is a method of curing concrete using high pressure steam at temperatures of 160-190°C (at 6-20 atmospheres steam pressure) to accelerate concrete strength gain. It is used particularly in the manufacture of Autoclaved Aerated Concrete (AAC).</p>	<p>P.V-S.15.4.4</p>
<p>Autogenous Shrinkage</p> <p>Autogenous shrinkage occurs in cement paste and comes about because water is being removed from the capillary pores over time to facilitate the ongoing hydration reaction, causing the paste to shrink. In low W/C ratio mixes the level of autogenous shrinkage might be expected to be higher but the more rigid skeleton tends to limit it. Similarly, the autogenous shrinkage of paste in a concrete mix is lower than with a cement plus water paste as the autogenous shrinkage is restrained by the aggregate. A typical level of autogenous shrinkage in concrete is about 50 microstrain.</p>	<p>P.II-S.1.3.2</p>

B

<p>Bar Chair</p> <p>The embedded items within reinforced concrete elements, which are used to maintain the position and cover of steel reinforcement during construction to ensure durability, strength and serviceability of the as-built elements (see also AS /NZS 2425:2014)</p>	<p>P.V-S.11.3.3</p>
---	----------------------------

<p>Barrier Walls</p> <p>Barrier walls (also known as jersey barriers) are slip-formed concrete structures used to separate lanes on major roads or to separate roads from tunnel walls etc. On modern roads, these are able to be produced as cast-in-place structures instead of being a series of discrete elements as was the case previously.</p>	<p>P.VI-S.19.3.5</p>
<p>Batch (Concrete)</p> <p>A quantity of concrete containing a fixed amount of ingredients and produced in a discrete operation.</p>	<p>P.III.2 P.IV-S.9.2 P.IV-S.10.3</p>
<p>Batching</p> <p>The process of combining the concrete ingredients in fixed proportions by weight or by volume.</p>	<p>P.III.2 P.IV-S.9.2 P.IV-S.10.3</p>
<p>Beams and Girders</p> <p>Precast concrete beams and girders come in a variety of shapes and sizes and are fundamental elements used in the construction of buildings and bridges etc. They may act as support structures only (e.g. L-beams and inverted tee-beams), or in some cases (e.g. single-tee and double-tee beams) they can form building floors or can provide the base for an in-situ concrete topping to act as the final floor. Super tee-girders and I-girders are common girder types typically used in bridge construction.</p>	<p>P.VI-S.20.3.2</p>
<p>Beam Form (and supports)</p> <p>Formwork and falsework used to support plastic concrete when beams are cast.</p>	<p>P.IX-S.27.3.1</p>
<p>Beam Shells</p> <p>Beam shells are long U-shaped beams that can contain the beam reinforcement and also be used to support floor planks. They can sit on a column and when the structure is finished they become integral with the planks and topping concrete.</p>	<p>P.VI-S.20.3.2</p>
<p>Binder</p> <p>In concrete technology the terms ‘binder’ and ‘cement’ are synonymous. However, while ‘cement’ is more definitive (see <i>Cement</i> below), ‘binder’ is more general in that it may refer to Portland cement alone, to Portland cement plus one or more SCM, or even to a non-Portland cement material (e.g. an <i>Alkali Activated Material</i> or a <i>Geopolymer</i> – see <i>Alternative Binder</i> above). When mixed with water, cements / binders form the ‘glue’ that binds the aggregate materials into the composite material called concrete. (Note: AS 1379 refers to complying ‘cement’ as a ‘hydraulic binder’ as is defined in <i>Hydraulic Cement</i> below.)</p>	<p>P.II-S.1.1 P.II-S.1.2.1 P.XI.7.1</p>
<p>Blue Metal</p> <p>A quarried, crushed aggregate rock that provides strength to concrete by binding with cement. Colour ranges from blue to black and size ranges from 5 mm to 20 mm. This term is not in common use currently.</p>	

<p>Bleed Water</p> <p>Bleed water appears on the surface of plastic concrete after it has been compacted and bull-floated, and (ideally) prior to final finishing. Bleeding is a consequence of the process of sedimentation – that is, the settling of heavy materials (e.g. cement and aggregate particles) in a mixture that contains a lighter component (e.g. water). While the concrete is still plastic the heavy particles are able to sink, leaving some water on the surface of the concrete. Sinking ceases once the concrete starts to stiffen. Bleed water may not always be obvious on the surface as the evaporation rate of water from the concrete surface may exceed the Bleed Rate. In this situation there is a heightened risk of Plastic Shrinkage Cracking.</p>	<p>P.V-S.14.4 P.VIII-S.25.2.3 P.VIII-S.26.3.7</p>
<p>Blended Cements (Type GB Cements)</p> <p>According to the requirements of AS 3972, blended cements are cements that (a) contain >7.5% fly ash or GGBFS or both, or (b) up to 10% silica fume, and (c) meet the performance requirements described in Table 2 of AS 3972. There is no upper limit for fly ash and GGBFS content in Type GB cements. The upper limit is determined by the performance of the Type GB cement – in particular the effect on setting time or mortar strength beyond the limits prescribed in the Standard.</p> <p>See also <i>General Purpose Blended Cement (Type GB)</i>.</p>	<p>P.II-S.1.2.3</p>
<p>Blinding Layer</p> <p>In construction, blinding is a base layer of weak concrete or cement stabilised sand that is laid on a paving sub-base to provide a clean, level and dry working surface.</p>	<p>P.I.2</p>
<p>Bony (Harsh) Mix</p> <p>A concrete mix made with a poorly ratioed composition such as too little water or too much cement and aggregate, leading to a less workable concrete mix.</p>	<p>P.III.3.2</p>
<p>Boxing</p> <p>A colloquial term for concrete formwork - see <i>Formwork</i>.</p>	
<p>Bracing and Props</p> <p>Bracing and props are important items used in precast concrete construction. Bracing is used to support vertical elements, while props are used to support horizontal elements. Precast panels are lifted into position and while the precast components are being assembled, and prior to them being fixed into position, the panels are stabilised using bracing. Props are used to support structures like cast-in-situ decks or beams while they gain strength. The proper use of bracing and props requires high quality engineering design input to ensure the safety of site personnel and the integrity of the structure.</p>	<p>P.VI-S.20.7.7</p>
<p>Brazil Test</p> <p>The 'Brazil Test' is a common name for the indirect tensile strength test for concrete. This measure of the tensile strength of concrete generally has a lower strength than the flexural strength test but higher than the direct tensile strength (refer to AS 1012.10).</p> <p>See also <i>Indirect Tensile Strength Test</i>.</p>	<p>P.VIII-S.26.4.4</p>

<p>Broom Finish</p> <p>A surface finish applied to create a non-slip surface. It is applied (a) using a stiff broom at the later stage of concrete finishing, and (b) usually at 90° to the direction of the path.</p>	<p>P.V-S.14.7.4 P.V-S.14.7.7</p>
<p>Building Code of Australia (BCA)</p> <p>The BCA in the National Construction Code (NCC) provides the minimum necessary requirements for safety, health, amenity and sustainability in the design and construction of new buildings (and new work in existing buildings) throughout Australia. It contains technical provisions for the design and construction of buildings and other structures.</p>	<p>P.XI.1.2</p>
<p>Bulk Density</p> <p>The bulk density of a material is the density of the uncompacted material in a natural state (e.g. the density of aggregate in a stockpile or cement in a silo). The bulk density is not used in mix design but is used in designing concrete plants and storage vessels for cement and fly ash plants. For silica fume, bulk density is an important issue. As produced, silica fume has a low bulk density. To be able to handle it in concrete plants or elsewhere it is often densified to improve ease of handling or made into a slurry (at 50-60% solids content) to allow it to be added to mixes more conveniently.</p>	<p>P.II-S.2.8 P.II-S.3.4.4</p>

C

<p>California Bearing Ratio</p> <p>The Californian Bearing Ratio (CBR) test is a penetration test used to evaluate the subgrade strength of roads and pavements. The results of these tests are used with the curves to determine the thickness of pavement and its component layers. This is the most widely used method for the design of flexible pavement (refer to AS 1289.6.1.1).</p>	<p>P.I.2.2</p>
<p>Cantilever Beam</p> <p>A cantilever beam is a structural beam that is fixed from being able to move freely at one end and is free at the other end. This design produces zero bending stress or shear stress at the free end and concentrates the greatest stresses at the fixed end.</p>	<p>P.I.3.3</p>
<p>Capillary Porosity (and Capillary Dis-continuity)</p> <p>Capillary porosity is a feature of Portland cement concrete. As water is taken up by the (relatively) slow hydration process the space left behind becomes capillary porosity. Concrete mixes with high W/C ratios have much higher levels of capillary porosity than do mixes with low W/C ratios. This porosity can allow fluids (gases and liquids) to penetrate into the concrete unless the porosity becomes dis-continuous. Capillary porosity can be made dis-continuous by (a) lowering the W/C ratio (= increasing the cement content); (b) curing; (c) using SCM's in the cementitious component.</p>	<p>P.VIII-S.25.3.2</p>

<p>Carbonation</p> <p>Reaction between carbon dioxide and a hydroxide or oxide to form a carbonate, especially in cement paste, mortar, or concrete. This is often called neutralisation where the pH in the concrete goes from a highly alkaline state to a more neutral state. This is important for durability as reinforcement in concrete has a higher risk of corrosion through carbonation. Also refers to the reaction with calcium compounds (e.g. lime) to produce calcium carbonate.</p>	<p>P.VIII-S.25.3.2</p>
<p>Casting Beds</p> <p>Casting beds are structures where concrete is cast, and the term is used particularly in the context of precast concrete manufacture. Casting beds may be in a factory where concrete elements are being made or may be set up adjacent to a building site where tilt-up panels are being cast. The design and operation of casting beds is an important element in determining the quality of the precast concrete products being produced.</p>	<p>P.VI-S.20.7.5</p>
<p>CemAssure</p> <p>The CemAssure scheme is owned and managed by the CemAssure Board of CemAssure Limited. CemAssure provides a process of third-party review of the conformity of despatched products including cement, fly ash, ground slag and amorphous silica with prevailing Australian, New Zealand or joint AS/NZS Standards and is accredited by the Joint Accreditation System of Australia and New Zealand (JAS-ANZ).</p> <p>Procedures include Annual or Bi-Annual Surveillance Auditing carried out by the Conformity Assessment Body. The Conformity Assessment Body auditors are independent of the cement and SCM suppliers being assessed and the CemAssure Board to ensure impartiality.</p>	<p>P.XI.7.1 P.XI.7.2</p>
<p>Cement</p> <p>Cement in the 'normal' concrete context generally refers to Portland cement which is by far the most common 'cement' material in use. Cement is however, a general term, which can be applied to any material which is able to bind materials (e.g. aggregates) together. The resultant concretes are generally named to reflect the type of cement or binder used – e.g. Portland cement concrete, polymer concrete, asphaltic concrete, geopolymer concrete.</p>	<p>P.II-S.1.1 P.XI.7.1</p>
<p>Characteristic Strength</p> <p>The Characteristic Strength of a concrete is the 28-day compressive strength level above which 95% of the concrete is expected to meet or to exceed. The characteristic strength is the value used by designers, in the ordering of concrete and for acceptance on delivery to the construction site. Projects covered by AS 3600 use concrete for which the characteristic strength is specified, and AS 3600 used characteristic strength as a basis for many of its design calculations.</p>	<p>P.VIII-S.25.3.1</p>
<p>Chemical Attack on Concrete</p> <p>Concrete is prone to attack by certain chemical species. Acids (low pH materials) readily attack concrete (a high pH material) and can cause significant damage. Acids may be found in industrial effluents and also in materials like fruit juices and dairy products. Sulfates also readily attack concrete. Sulfates are found in industrial effluents, in sewerage and in sea water. Sodium sulfate can react with lime to form an</p>	<p>P.VIII-S.25.3.2</p>

expansive calcium sulfate reaction product which can cause cracking; while magnesium sulfate can attack CSH itself and cause concrete to disintegrate.	
<p>Chlorides</p> <p>Chlorides are ubiquitous in the environment and can be problematic in concrete – most particularly in concrete containing embedded steel. In due course, chloride ions can penetrate through even low permeability concrete and ultimately reach steel reinforcing or other embedded steel. When that occurs, the passive layer protecting the steel from corrosion can be broken down and active corrosion can begin. Corroding steel expands and creates tensile stresses in concrete leading to cracking and potentially, to spalling. Concrete materials (cement, SCM's, admixtures) almost invariably have limits on maximum tolerable chloride concentration. AS 1379 also limits the total chloride content of concrete.</p>	<p>P.II-S1.4.7</p> <p>P.II-S.2.7.4</p> <p>P.VIII-S.25.3.2</p>
<p>Cohesiveness</p> <p>A measure of the ability of plastic concrete to resist segregation into its distinct components during handling, placing and compacting (a related measure being viscosity). Factors affecting plastic concrete cohesiveness include specific gravities of constituents, water content (higher 'consistency' results in lower cohesiveness) and aggregate grading (deficiency in fine aggregate increases likelihood of segregation, while too many fines cause difficulty in placing concrete). See also CCAA T41 (2002).</p>	P.VIII-S.25.2.3
<p>Cold Weather Concreting</p> <p>Concreting in cold weather (temperatures <5°C) brings with it an array of potential risks. The most obvious is that the cold weather will slow or stop the cement hydration reaction and prevent the concrete setting and/or gaining strength in a reasonable time. In extreme cold the mix water will freeze and damage the pore structure in the concrete. To deal with cold weather issues a number of actions can be taken including (a) use a Type HE cement, (b) use hot water for mixing, (c) use accelerating admixtures, (d) insulate forms and the finished surface or place concrete inside a heated enclosure.</p> <p>Low temperatures = low rates of strength gain but generally higher later-age strengths.</p>	P.V-S.18.3
<p>Column Forms</p> <p>Formwork that is used to support columns when they are cast.</p>	P.IX-S.27.3.1
<p>Compaction</p> <p>Compaction of concrete is one of the important site processes that is carried out to ensure the concrete reaches its design strength, density and permeability. Compaction must be carried out around all slab elements to be fully effective. The process of compaction removes air entrapped during the mixing and transport/transfer processes and consolidates the paste and aggregate components.</p>	P.V-S.13.3
<p>Compacting Factor Test</p> <p>The Compacting Factor Test provides a measure of the compaction achieved in a plastic concrete sample upon which a standard amount of work has been done. The standard amount of compactive effort is delivered through the design and operation of the test apparatus. The compaction achieved during testing is compared with that achieved for a fully compacted sample of the same concrete. Compacting Factor provides a better measure of workability than slump, and particularly for 'low slump' mixes.</p>	P.VIII-S.25.2.4

<p>Compressive Strength Testing</p> <p>Test made on a test specimen of mortar or concrete to determine the compressive strength.</p>	<p>P.VIII-S.26.4.3</p>
<p>Compressive Strength</p> <p>Compressive Strength of a concrete mix is a measure of the ability of concrete to resist loads that would tend to crush it. It is measured using a standard test cylinder when prepared and tested in accordance with AS 1012.8.</p>	<p>P.VIII-S.25.3.1</p>
<p>Concrete</p> <p>A mixture of cement, aggregates, and water with or without the addition of chemical admixtures or other materials.</p>	<p>Introduction</p>
<p>Concrete Cover</p> <p>Concrete cover refers to the amount of concrete that lies between the surface of an element and any embedded steel – typically reinforcement. Having adequate concrete cover is critical in preventing corrosion of the steel and AS 3600 defines minimum concrete cover requirements for different exposure conditions and where different strength concretes are being used.</p>	<p>P.VIII-S.25.3.2</p>
<p>Concrete Pavement</p> <p>Concrete pavement is an efficient type of road structure – particularly for major roads and highways. Concrete roads are placed using a dedicated machine (see ‘Paving Machines’) and the concrete may be placed in single-lane or multi-lane formats. Concrete roads are used extensively in NSW (and overseas) but not so much in other Australian States. Concrete roads reduce maintenance costs and are long-life structures.</p>	<p>P.I.2</p> <p>P.V-S.14</p> <p>P.V-S.17.4</p> <p>P.VI-S.19.3.2</p>
<p>Concrete Plant</p> <p>A ‘concrete plant’ is a manufacturing site for concrete, which may be of several types. The most common concrete plant is the Dry-Batch Plants, while Wet-Batch Plants are also widely used. For some forms of concrete (e.g. Roller Compacted Concrete – RCC) a Pug Mill may be used. A Pug Mill is a batch plant that combines concrete materials on a volumetric basis (as opposed to the mass basis normally used). Concrete plants are found in most cities and towns as plastic concrete is a perishable product that can only be transported for relatively short times/distances.</p> <p>See also <i>Dry-Batch Plant</i>, <i>Pug Mill</i> and <i>Wet-Batch Plant</i>.</p>	<p>P.IV-S.9.2</p>
<p>Concrete Pump</p> <p>See <i>Pump / Concrete Pump</i>.</p>	<p>P.IV-S.10.4.1</p> <p>P.V-S.12.4.6</p>
<p>Concrete Test Cylinder</p> <p>A concrete test cylinder is the test specimen of compacted concrete that has undergone initial curing in the cylinder mould and is then placed into a standard curing environment for use in the compressive strength test and indirect tensile strength test (refer to AS 1012.8.1).</p>	<p>P.VIII-S.25.3.1</p> <p>P.VIII-S.26.4.3</p>
<p>Consistency</p> <p>A term used to describe the ease with which a concrete will flow and is often used to reflect the ‘degree of wetness’ of a concrete mix. It is different to workability – in</p>	<p>P.VIII-S.25.2.2</p>

practice the two terms are often confused and merged into one descriptor – namely ‘slump’.	
<p>Construction Joint</p> <p>A construction joint is generally created where a concrete placement is ceased with the intention of joining on another placement of concrete in the same structure at a time when the earlier placement will have set and hardened. The joint is generally required to pass design stresses across the joint and will either allow limited movement or no movement at the joint.</p>	<p>P.I.2.2</p> <p>P.V-S.17.4.2</p> <p>P.XI.15.18</p>
<p>Contraction Joint</p> <p>A contraction joint is a line of weakening formed into a concrete slab on ground. This can be formed by forming the joint while the concrete is still in plastic state (using a jointing tool) or can be cut into the hardened concrete surface using a concrete saw. The cut is generally to a depth of between 25% and 30% of the slab depth.</p>	<p>P.I.2.2</p> <p>P.V-S.17.4.3</p> <p>P.XI.15.18</p>
<p>Controlled Low Strength Material (CLSM)</p> <p>Controlled low strength material (CLSM) is also known as Flowable Fill. It is a low strength backfill material that is used to embed pipes, to fill trenches and to fill cavities. Typical 28-day strengths are about 1-2 MPa. CLSM can be made with high levels of fly ash to promote flow or with a high dose of AEA. The cementitious content of a fly ash mix may be (say) 50 kg/m³ of cement plus 300 kg/m³ of fly ash with the balance as sand. The water content of this type of mix is high – in the range of 250-300 L/m³.</p>	<p>P.II-S.2.7.5</p>
<p>Corrosion</p> <p>Corrosion is problematic in concrete containing embedded steel – as reinforcement or for some other reason. Anything that initiates corrosion of the embedded steel is an issue that needs to be controlled. Chloride ion penetration is problematic, as is carbonation (where the pH of the concrete may be reduced to a level where steel passivation is compromised). Steel corrosion leads to cracking which can then lead to spalling and the appearance of ‘concrete cancer’. In part, corrosion can be managed through the use of high quality (low permeability) concrete and sufficient concrete cover.</p>	<p>P.VIII-S.25.3.2</p>
<p>Crack</p> <p>A complete or incomplete separation of concrete into two or more parts produced by breaking or fracturing (also referred to as ‘fracture’).</p>	<p>P.V-S.17</p> <p>P.VIII-S.25</p>
<p>Crack Mouth Opening Displacement (CMOD)</p> <p>A value determined from a three-point loaded beam using European standard EN 14651 method. The measured width of a crack formed in the bottom of a centrally loaded beam with a pre-formed joint is carried out with increasing loading of the beam. The CMOD values of 0.5 mm, 1.5 mm, 2.5 mm and 3.5 mm – defined by F₁, F₂, F₃ and F₄, respectively. This method is used to assess the impact of steel and structural synthetic fibres on concrete flexural toughness (refer to AS 3600).</p>	<p>P.I.5.2</p> <p>P.II-S.7.2.2</p>
<p>Crazing Cracks</p> <p>These are very fine (spider web-like) cracks which appear on the surface of concrete after it has been exposed to the atmosphere for some time. It can occur on both trowelled and formed surfaces but is more noticeable on trowelled surfaces, particularly when the surface has been wetted and allowed to dry off.</p>	<p>P.V-S.17.3.1</p>

<p>Creep</p> <p>Concrete creep is a form of concrete deformation that occurs over long periods of time (e.g. shortening of columns; deflection of floors or slabs; loss of strength in prestressed concrete). Creep begins when load is applied to the concrete and reduces (but not totally) when the load is removed. The extent of creep depends on a number of factors including the load applied, the modulus of elasticity, the strength at the time of loading and conditions such as temperature and RH.</p>	<p>P.VIII-S.25.3.2</p>
<p>CSH – Calcium Silicate Hydrate</p> <p>CSH is the primary cement hydration product – the gel (or glue) material that binds the aggregate materials to form concrete. Calcium silicate minerals in cement react with water to form the hydrate gel product. If heated to sufficiently high temperatures the hydrate loses water and the CSH gel breaks down.</p>	<p>P.II-S.2.2</p>
<p>Curing</p> <p>Curing is a process undertaken after concrete has hardened – the aim being to control moisture loss from the concrete to allow the hydration reaction to continue and the concrete to achieve its full potential. Curing can be achieved by (a) minimising moisture loss from the concrete surface using an impermeable membrane, (b) preventing moisture loss by continuously wetting the surface, and (c) keeping the surface moist while increasing concrete temperature to maximise strength gain.</p>	<p>P.V-S.15.4</p>
<p>Curing Compound</p> <p>A compound sprayed onto the surface of hardened concrete immediately after finishing to limit moisture loss and maximise concrete strength gain and durability.</p>	<p>P.V-S.15.4.2 P.XI.7.7</p>
<p>Cusum Chart</p> <p>A quality control charting method used to assess variation in measured properties from a target average value. The method takes account of expected variability and provides early warning of a significant variance trend (refer to AS 3940).</p>	<p>P.VIII-S.26.5.6</p>

D

<p>Delayed Ettringite Formation ‘DEF’</p> <p>Delayed ettringite formation (DEF) may result in the expansion and cracking of concrete associated with the delayed formation of the mineral ettringite which is a normal product of early cement hydration. DEF is generally a result of high early temperatures in concrete (typically an early curing temperature above 70°C to 80°C) which prevents the normal formation of ettringite. The likelihood of this occurring is increased where thicker sections of concrete are cast (mass concrete), where concrete contains low levels or no SCM and contains higher levels of Portland Cement. Poorly controlled Heat Accelerated Curing concrete temperature can also influence DEF.</p> <p>See also <i>Heat Accelerated Curing</i></p>	<p>P.XI.16.6</p>
--	-------------------------

<p>Dematerialisation</p> <p>Dematerialisation is one element used to establish the sustainability of a product or process. Dematerialisation involves modifications to a building or building element that result in less material being used in that building or element than has been historically used – without reducing the effectiveness of the building or element (or perhaps improving it). A ‘concrete’ example is the use of post-tensioned concrete floors in high-rise construction. Post-tensioned floors are stronger than cast in-situ reinforced floors and can be made thinner – using less concrete – and this contributes to the ‘sustainability performance’ of the structure.</p>	<p>P.VI-S.20.3.1</p>
<p>Density</p> <p>The mass per unit volume of concrete. Can be measured dry and wet. Dry density is the mass per unit volume of a dry substance at a stated temperature. Wet density is defined in AS 1012.</p> <p>See also <i>Bulk Density</i>.</p>	<p>P.II-S.3.4.4</p> <p>P.III.2.8</p> <p>P.VIII-S.25.3.1</p>
<p>Design Strength</p> <p>Nominal strength of concrete usually taken as the characteristic compressive strength of concrete, multiplied by a strength reduction factor (<i>phi</i> factor).</p>	
<p>Distribution Methods</p> <p>Concrete can be distributed on a job site by a variety of methods including ‘off the (truck) chute’; barrow; crane and bucket; conveyor; tremie; pumps and pipelines. Consideration needs to be given to volume to be distributed, location, cost, available labour and nature of the concrete to determine the most appropriate distribution method.</p>	<p>P.V-S.12.4</p>
<p>Dry-Batch Plant</p> <p>A dry-batch plant is a concrete producing operation in which the concrete raw materials are ‘dry-batched’ into an ‘agitator’ or transit mixer where the concrete mixing occurs. Once fully mixed and checked for slump, the concrete is despatched to the job site. This type of operation became the norm in Australia from about the late 1950’s.</p>	<p>P.IV-S.9.2.5</p>
<p>Dry-Shake Toppings (and Driers)</p> <p>Dry-shake toppings may be used to impart special finishes to the surface of concrete but should not be used to mask quality or finishing deficiencies. Driers are sometimes used to ‘mop up’ excess bleed water to speed up finishing. They should not be used for this purpose and the drier/water mix should not be worked into the concrete surface. This type of use will invariably result in a dusty final concrete surface.</p>	<p>P.V-S.14.7.2</p>
<p>Drying Shrinkage</p> <p>Shrinkage of the hardened concrete resulting from water loss by evaporation through the surface of the concrete. The water loss is from the paste. Lower paste content (or higher aggregate content) means lower drying shrinkage. Drying shrinkage is expressed in terms of the unit ‘microstrain’. It is measured using procedures described in AS 1012.13.</p>	<p>P.II-S.4.5.5</p> <p>P.VIII-S.25.3.2</p> <p>P.VIII-S.26.4.6</p>
<p>Ductile Mesh</p> <p>A higher ductility class reinforcing mesh for use in applications where higher ductility is a requirement.</p>	<p>P.II-S.6.2.3</p>

<p>Ductility Class of Reinforcement</p> <p>The relative ductility of steel reinforcement is identified by a 'ductility class' of 'L', 'N' or 'E' representing, in order, Low ductility, Normal ductility or Earthquake (high) ductility. Each is specified by a minimum ductility ratio (steel failure stress / yield stress).</p>	<p>P.II-S.6.2.1</p> <p>P.V-S.11.2.1</p>
<p>Durability</p> <p>Durability is the ability of a structure and its component members to perform the functions for which they have been designed, over a specified period of time, when exposed to their particular environment.</p>	<p>P.II-S.2.9</p> <p>P.VIII-S.25.3.2</p>
<p>Duty of Care</p> <p>Duty of Care is a legal responsibility that falls on all employers and employees in relation to matters of occupational health and safety and the environment. The duty of care responsibility requires that everyone exercises reasonable standards of care when performing acts that may harm other people or the environment. Such acts must be done with a level of care commensurate with the risks and includes the carrying out of acts and omitting to carry out acts that carry risks.</p>	<p>P.IX-S.28.1</p>
<p>Dynamometer</p> <p>A device for measuring the force applied (in this reference it applies to measuring the post tensioning force).</p>	<p>P.V-S.11.6.4</p>

E

<p>Edging</p> <p>Edging is carried out using a special tool to provide a quarter-round edge around the perimeter of a concrete slab. This type of edge improves the appearance of the slab and helps to prevent chipping of edges and corners during use. Warehouse floors and slabs which will have tile or carpet coverings should not be 'edged'.</p>	<p>P.V-S.14.6</p>
<p>Efflorescence</p> <p>A generally white deposit formed when water-soluble compounds emerge in solution from (generally new) concrete, masonry, or plaster substrates and precipitate by reaction (such as carbonation of lime) or crystallise (by evaporation).</p>	<p>P.V-S.16.5</p>
<p>Elastic Modulus</p> <p>An elastic modulus (also known as modulus of elasticity) is a quantity that measures an object or substance's resistance to being deformed elastically (i.e., non-permanently) when a stress is applied to it. Commonly expressed as stress/strain in units of kPa, MPa or GPa. This property applies to confined soils as well as concrete and reinforcement.</p>	<p>P.I.2.2</p> <p>P.VIII-S.26.4.8</p>
<p>Embodied CO₂</p> <p>Embodied carbon dioxide is a measure of the amount of CO₂ produced in the extraction, processing, manufacturing and delivery of building materials to a building</p>	<p>P.X.3.3</p>

site. In terms of the whole-of-life CO ₂ use, embodied carbon represents about 20-50% of the total carbon intensity.	
<p>Embodied Energy</p> <p>Embodied energy is the sum of all of the energy consumed in extraction, processing, manufacturing and delivery of building materials to a building site. In terms of the energy consumption of a building in its whole life, the embodied energy represents about 10-20% of the total energy.</p>	P.X
<p>Entrained Air</p> <p>See <i>Air Content</i>.</p>	P.II-S.5.2.2
<p>Entrapped Air</p> <p>See <i>Air Content</i>.</p>	P.V-S.13
<p>Environmental Product Declarations (EPD's)</p> <p>Environmental Product Declarations (EPD's) are independently produced and verified documents that provide information on the life cycle environmental impact of products. They are prepared in accordance with Product Category Rules and in accordance with ISO 14025.</p>	P.X.4.5
<p>Expansion Joints</p> <p>Joints placed along pathways prone to cracking in typically large concrete slabs (floors, bridges, footpaths etc.) to control and mitigate cracking. Expansion joints can take on forms such as bridge, masonry, railway and pipe expansion joints and can contain compressible filler material to allow expansion and contraction (see also ACI CT-18).</p>	P.V-S.17.4.4 P.XI.15.18
<p>Exposed (Aggregate) Concrete</p> <p>Exposed aggregate concrete is a decorative concrete finish in which aggregate (usually specially chosen) is exposed at the surface of the concrete by washing off some of the cement mortar using a light water spray after initial setting has occurred. The aggregate to be exposed can be (a) incorporated in the concrete mix or (b) added after concrete placement by 'seeding' the aggregate into the surface and using a bull float to emplace it in the surface.</p>	P.V-S.14.7.7
<p>Exposure Class or Classification</p> <p>Exposure classification or classes are derived from AS 3600 for the case of concrete structures. The classes relate to the severity of the environment in which the concrete is placed or is located while the structure is in service. For concrete aggregates, AS 2758.1 (Appendix B) uses a similar exposure classification system to define aggregate durability requirements. In each case the exposure class is identified as A1, A2, B1, B2, C1, C2 or U from least severity to greatest severity of environment.</p>	P.XI.9.5
<p>External Vibration</p> <p>In certain cases, external vibration may be applied to concrete formwork to bring about compaction. Examples of where this may be used include in precast operations and for thin elements. Where external vibration is used, the formwork must be very rigid and leak-proof and the concrete should be placed in lifts to allow the air to be removed during vibration. Another example of external vibration is a vibrating table – where the</p>	P.V-S.13.6.4 P.IX-S.27.8.3

formwork is attached to a vibrator and not the reverse. These systems are used in the manufacture of concrete blocks.

See also *Form Vibrators*.

F

False Setting False setting is a stiffening of a cement and water paste that can be reversed by rapid stirring of the mix. False setting is caused by too high a proportion of 'plaster' – a dehydrated form of gypsum. While partial dehydration of gypsum is required during the cement milling process, if it proceeds too far it can lead to false setting, which in most cases is a controllable issue.	P.II-S.1.2.2
Falsework Falsework consists of the propping, bracing and fixings that support formwork and transfer load to the supporting foundation (e.g. the ground). Falsework should be considered as an essential part of the formwork system.	P.IX-S.27.7 P.XI.15.9
Fibres <i>Alkali Resistant Glass Fibres</i> Alkali Resistant (AR) Glass Fibres are designed specifically for use in concrete. They are manufactured from a specially formulated glass composition with an optimum level of Zirconia (ZrO ₂) to be suitable for use in concrete. <i>Fibrillated Fibres</i> Fibrillated Fibres are the general term for fibres that have been processed (refined) to develop fibres with a higher surface area and a 'branched structure'. <i>Mineral Fibres</i> Mineral Fibres generally refer to fibres sourced from mined minerals. Examples are Asbestos Fibres and Basalt Fibres. <i>Monofilament Fibres</i> A monofilament fibre is generally referring to a synthetic fibre where each fibre is composed of a homogenous material. Typically, these are produced using an extrusion process. <i>Natural Fibres</i> Natural fibres generally refer to fibres sourced from plants or animal hair. <i>Structural Synthetic Fibres</i> 'Structural' synthetic fibres (sometimes referred to as 'macro synthetic fibres') are made from blends of polymers and were originally developed to provide an alternative to steel fibres in some applications.	P.I.5.1 P.II-S.7.2

<p>Fibre Reinforced Concrete</p> <p>Fibre reinforced concrete has been used for decades, with both steel and plastic fibres in common use. In some places, natural fibres (e.g. straw and hemp) are also used, as are glass fibres. As a general comment, fibre reinforcing is used to improve the structural integrity of concrete. Steel fibres are often used to increase tensile capacity as well as improve abrasion resistance and control crack widths. Plastic fibres (e.g. polypropylene or nylon) are used to improve cohesiveness, reduce crack widths, improve resistance to plastic shrinkage cracking and improve freeze-thaw resistance. Fibre dimensions and addition rates vary considerably and specific advice regarding their use should be sought from suppliers.</p>	<p>P.I.5 P.VII-S.24.3.2</p>
<p>Finish Classes</p> <p>Off-form concrete finishes may be classified (or specified) as being in one of 5 classes defined in AS 3610. Class 1 – highest class; for monumental pieces, single pour; Class 2 – good quality architectural precast concrete; Class 3 – visual importance, but not necessarily architecturally; Classes 4 and 5 – visual quality not important, concrete may not be generally visible. Test panels should be done for Class 1 and Class 2 finishes. See also Table 16.1 in P.V-S.16.</p>	<p>P.V-S.16.3.1</p>
<p>Finishing</p> <p>Finishing concrete can be considered to be the combination of two processes – compaction and finishing. A good finish does not imply quality concrete and compaction is a critical activity. Finishing involves sequential processes which are typically screeding, bull floating, floating and final finishing. Timing of these operations is critical to achieving a high-quality surface finish.</p>	<p>P.V-S14.1</p>
<p>First Flush Systems</p> <p>In concrete batch plants, first flush water containment systems are used to collect to the (nominally) first 20 mm of rainfall (in a 24-hour period) – this rain being that most likely to be contaminated by dust, oil and other materials normally residing on the plant site. Rain after the nominal first 20 mm is considered to be clean and is able to be discharged off site. (see also D. B. Martinson, T. H. Thomas <i>Quantifying the First-Flush Phenomenon: Effects of First-Flush on Water Yield and Quality</i>, 2009).</p>	<p>P.II-S.4.2</p>
<p>Fixed End Beam</p> <p>A fixed end beam is a structural beam that is fixed from being able to move freely at both ends. These fixed ends generally reduce deflection of the beam.</p>	<p>P.I.3.3</p>
<p>Flash Setting</p> <p>Flash setting is the very rapid and irreversible stiffening of a cement plus water mixture that occurs if the cement does not contain a small proportion of a sulfate-containing material (e.g. gypsum). The sulfate-containing material partially dissolves in the water and prevents the rapid hydration of the tri-calcium aluminate mineral which is the primary cause of flash setting.</p>	<p>P.II-S.1.2.2</p>
<p>Flexural Strength</p> <p>The maximum load per unit cross-sectional area (stress) in the extreme tensile fibre that a beam can withstand when a loading is applied on a beam and perpendicularly to the beam's longitudinal axis.</p>	<p>P.VIII-S.25.3.1 P.VIII-S.26.4.5</p>

<p>Flexural Tensile Strength Test or Modulus of Rupture Test</p> <p>A test designed to assess the flexural tensile strength of concrete carried out in accordance with AS 1012.11.</p>	<p>P.VIII-S.25.3.1 P.VIII-S.26.4.5</p>
<p>Floating</p> <p>Floating the surface of a concrete slab can occur as two separate tasks. Immediately after screeding, the surface may be bull-floated to even out the surface and embed any larger pieces of aggregate. After bull-floating the surface should not be worked further until bleed water has left the surface and it is sufficiently strong to cope with additional finishing processes. After the bleed water has gone, the surface may be floated by hand or by machine to densify the surface and begin to work towards a final finish.</p>	<p>P.V-S.14.4</p>
<p>Fly Ash</p> <p>Fly ash is a fine, inorganic residue formed from the combustion of black coal in power stations. Fly ash derives from mineral matter mined with the coal. This mineral matter is typically sand and clay, and occasionally, other mineral species. The coal and the mineral matter are milled prior to combustion which separates the coal and mineral matter particles. In the flame, the coal burns off and the mineral matter (generally) melts in the high temperature (1,800°C) combustion zone. When the flue gas containing the fly ash passes into cooler areas of the furnace the particles solidify into (quite) spherical particles. They are ultimately removed from the flue gas by collection devices (electrostatic precipitators or fabric filters) before the clean flue gas is emitted to the atmosphere via the stack. The fly ash can be collected and processed to a standard that allows it to be used as a supplementary cementitious material.</p>	<p>P.II-S.2.6</p>
<p>Form Face</p> <p>The form face is the surface of the formwork that creates the finish on the exposed concrete face. Different surface finishes may be created by steel, plywood or timber formwork or by using a form liner.</p>	<p>P.IX-S.27.2</p>
<p>Form Liners</p> <p>Form liners are effectively a mould which is placed inside the form. The patterns or surface texture on the liner are effectively imposed on the surface of the concrete when the plastic concrete takes up the shapes on the liner surface. These (decorative) surface effects remain embossed in the hardened concrete. Form liners may be created from cardboard, wood, rubber etc. The type of material used is dictated to some extent by the amount of re-use required.</p>	<p>P.IX-S.27.4.3</p>
<p>Form Vibrators</p> <p>Form vibrators are used to compact concrete by attaching them to the outside of formwork – most often in precast factory situations. They require very securely constructed formwork. In another type, the formwork may be constructed on a vibrating table which imparts compaction forces. These systems are more often used in manufacturing concrete products (e.g. blocks) where stiff concrete mixes are used.</p> <p>See also <i>External Vibration</i>.</p>	<p>P.V-S.13.6.4 P.IX-S.27.8.3</p>
<p>Formwork</p> <p>Total system of support for freshly placed concrete including the mould or sheathing that contacts the concrete as well as supporting members, hardware, and necessary bracing (also referred to as shuttering).</p>	<p>P.IX-S.27 P.XI.15.10</p>

<p>Formwork Stripping</p> <p>Formwork stripping in cold conditions needs considerable care to (a) ensure that the concrete has gained sufficient strength to allow formwork to be safely removed, and (b) to ensure that a high temperature differential between the core and the surface of the element is not created – which, if it occurred, would increase the risk of thermal cracking.</p> <p>See also <i>Stripping Times</i>.</p>	<p>P.V-S.18.3.6</p> <p>P.IX-S.27.8.4</p>
<p>Freezing and Thawing</p> <p>The exposure of concrete to cycles of freezing and thawing can lead to serious damage to the surface of concrete. Unless this has been anticipated, the free water in the concrete will freeze and melt with each freezing cycle – the freezing part of this cycle causing the water to expand which increases tensile stresses within the concrete surface – leading ultimately to the surface breaking apart. To overcome this, air (at about 5% level) is entrained in the concrete. The fine, evenly distributed air bubbles provide space for the water to expand into, thus reducing stresses in the surface of the concrete.</p>	<p>P.VIII-S.25.3.2</p>

G

<p>Gang Forms</p> <p>Gang forms are typically modular formwork components that can be connected together, and when braced, moved (by crane) as a complete unit. Gang forms allow increased construction efficiency when the same formwork components are able to be re-used in various locations in a structure without having to break the formwork down into its individual components and to re-build it continually.</p>	<p>P.IX-S.27.5.2</p>
<p>General Purpose Blended Cement (Type GB)</p> <p>According to the requirements of AS 3972, blended cements are cements that (a) contain >7.5% fly ash or GGBFS or both, or (b) up to 10% silica fume, and (c) meet the performance requirements described in Table 2 of AS 3972. There is no upper limit for fly ash and GGBFS content in Type GB cements. The upper limit is determined by the performance of the Type GB cement – in particular the effect on setting time or mortar strength beyond the limits prescribed in the Standard.</p> <p>See also <i>Blended Cements (Type GB Cements)</i>.</p>	<p>P.II-S.1.2.4</p>
<p>General Purpose Cement (Type GP)</p> <p>Type GP cement is described in AS 3972 as a hydraulic cement which may contain, at the discretion of the manufacturer, Portland cement plus a combination of mineral additions up to a maximum of 7.5% by mass.</p>	<p>P.II-S.1.2.4</p>
<p>General Purpose Limestone Cement (Type GL)</p> <p>Type GL cement is defined in AS 3972 as a hydraulic cement that contains, at the discretion of the manufacturer, Portland cement plus limestone alone or in combination with minor additional constituents (maximum 5%) at levels of 8-20% by mass.</p>	<p>P.II-S.1.2.2</p>

<p>Geopolymers</p> <p>The term 'geopolymer' was coined by J. Davidovits in the 1970's as a name for a class of alternative binder materials that he patented. These materials are typically alkali activated materials, with alkali activation by strong alkalis, often in conjunction with sodium silicate. Davidovits proposes that these are polymeric materials that are different from the hydrated compounds formed when either cement hydrates (by reaction with water) or slag is activated by strong alkaline materials. The term 'geopolymer' is used by some, and particularly in Australia, for all alkali activated binders regardless of the nature of the reaction product. RILEM, a European expert group who are developing specifications, Standards and test methods for AAM's, are of the view that all of these binders are AAM's and that 'geopolymer' is a commercial name.</p> <p>See also <i>RILEM</i>.</p>	<p>P.VII-S.23.3</p>
<p>GGBFS</p> <p>GGBFS is Ground Granulated Blast Furnace Slag. When iron blast furnace slag is rapidly cooled (i.e. quenched by air or water spray) it forms a glassy product known as Granulated Blast Furnace Slag (GBFS). When the GBFS is milled in a 'cement' mill to a fineness level higher than Portland cement it becomes GGBFS. GGBFS is an excellent Supplementary Cementitious Material which is able to be substituted for Portland cement at levels of up to about 70%.</p> <p>See also <i>Slag</i>.</p>	<p>P.II-S.2.2.7</p>
<p>Girder Wrap</p> <p>A reinforcing mesh suitable for adding strength to major structural beams (e.g. bridge sections).</p>	<p>P.II-S.6.2.3</p>
<p>Grading (Individual Material)</p> <p>The distribution of particle sizes in an aggregate material (see also ACI CT-18).</p>	<p>P.II-S.3.4.2</p>
<p>Grading (Combined)</p> <p>The combination of fine and coarse aggregate materials of varying size, such that not more than 45% passing any sieve is retained on the following sieve grade during sieve analysis testing (see also ASTM C33/C33M – 18).</p>	<p>P.II-S.3.4.2</p>
<p>Granolithic Topping (Grano)</p> <p>A surface layer of concrete, suitable for use as a wearing surface finish to floors, with specially selected aggregate of suitable properties, that may be laid on a base of either fresh or hardened concrete. Can also be achieved by screeding (see also ACI CT-18).</p>	<p>P.V-S.14.7</p>
<p>Graphic Concrete</p> <p>Graphic concrete involves the creation of complex images on the surface of concrete walls and is used particularly with precast concrete. A couple of techniques are used including (a) selective use of retarders under form liners to create contrasts between coarser and finer finishes to form the images, or (b) thermochromatic compounds added to the concrete which are stimulated using wire-heating systems under microprocessor control to create coloured images.</p>	<p>P.VII-S.24.3.9</p>

<p>Gravity Dam</p> <p>A gravity dam is a dam constructed from concrete or stone masonry and designed to hold back water by using the weight of the material alone to resist the horizontal pressure of water pushing against it. Gravity dams are designed so that each section of the dam is stable and independent of any other dam sections.</p>	<p>P.I.2.4 P.IV-S.10.4.1</p>
<p>Green Star</p> <p>Green Star is a sustainability rating system developed by the Building Council of Australia to provide a 'sustainability score' for a building – currently for office buildings and apartment blocks – with the score being represented as a 'star rating'. 1-Star = minimum practice; 4-Stars = Best Practice; 5-Stars = Australian Excellence; 6-Stars = World Leadership.</p>	<p>P.X.4.3</p>
<p>Gypsum</p> <p>Gypsum is added to clinker during the milling process to make cement. The gypsum (in a partially dehydrated form) provides sulfate ions into the paste formed when water is added to the cement. The sulfate ions react with the tri-calcium aluminate mineral in cement clinker to slow the hydration reaction of this mineral. If sulfate was not added, the mineral would hydrate very quickly (called Flash Setting), forming a solid compound which would make the paste/mortar/concrete stiff and unworkable. Gypsum is added at about 5% of the mass of cement clinker.</p>	<p>P.II-S.1.2.2</p>

H

<p>Heat Accelerated Curing</p> <p>The rate of strength growth of concrete can be increased by increasing the temperature of the concrete, and one way this is done in practice is by steam curing and another method, with similar resulting effect on concrete, is using hot water to raise the temperature of the forms surrounding the concrete. Heat accelerated curing is routinely used in the manufacture of precast concrete elements. Heat accelerated curing is a multi-stage process that has to be highly controlled to achieve optimum concrete strengths and economic efficiency.</p> <p>See also <i>Steam Curing</i>.</p>	<p>P.XI.17.9.1</p>
<p>Heat of Hydration</p> <p>Heat in the form of 'Heat of Hydration' is a product of the hydration reaction between cement and water. For concrete cast in large masses, the heat generated from the hydration reaction cannot escape and the core temperature of these elements can be quite high (up to 80°C). While the high temperature itself can be problematic, so too is the temperature differential between the core and the surface of the element. Temperature differentials of >20°C can lead to high tensile stresses and cracking. There are a variety of ways of reducing concrete temperatures and dealing with potentially high temperature differentials (e.g. using Type LH cements, cooling aggregates, using ice as part of the mixing water).</p>	<p>P.II-S.1.4.2</p>

<p>High Alumina Cement (HAC)</p> <p>HAC is a very different material to Portland cement in terms of its mineralogy and its manufacture. HAC is manufactured from bauxite and limestone and compared to Portland cement has a high alumina content and a low calcium content. HAC is characterised by rapid strength gain and high heat of hydration. It is a refractory cement and used in furnaces and other high temperature environments. One detriment with HAC is that HAC concrete exposed to warm humid environments can undergo a 'conversion' reaction with a resulting significant loss in strength.</p>	<p>P.II-S.1.2.4</p>
<p>High Early Strength Cement (Type HE)</p> <p>Type HE cements are typically finely ground general purpose cements. They are used in applications where higher early-age strengths are needed (e.g. precast concrete, post-tensioned slabs).</p>	<p>P.II-S.1.2.4</p>
<p>High Strength / Ultra High Strength Concrete</p> <p>In AS 1379 the highest compressive strength noted is 100 MPa. Today the use of strengths of this magnitude and higher is not uncommon, with strengths in columns for high-rise buildings now approaching 150 MPa. Ultra-high strength concretes with compressive strengths >200 MPa are also being produced. These are being used in high-impact structures and in bridges (for decks and girders) and for seismic retrofits. See also <i>Reactive Powder Concrete</i>.</p>	<p>P.VII-S.24.3.3</p>
<p>Hold Point</p> <p>A Hold Point is a specified, mandatory verification point beyond which work cannot progress without approval by the designated authority, typically the Engineer or Consultant or 3rd Party Inspector. These are commonly added to specifications to ensure that work cannot proceed before appropriate checks are made of documentation.</p>	<p>P.XI.5.1</p>
<p>Hollowcore</p> <p>Hollowcore is a factory-produced suite of concrete products that are becoming more widely used in commercial, industrial and domestic construction. Hollowcore comes in two main formats – panels and 'slabs' or 'planks'. Hollowcore panels can replace cast in-situ reinforced concrete panels or tilt-up panels. Hollowcore planks create wide-span flooring that has many advantages overcast in-situ flooring. The prestressed hollowcore products are strong, lightweight elements that have a wide range of applications.</p>	<p>P.VI-S.20.5</p>
<p>Hot Water</p> <p>Hot water is sometimes used in cold climates to raise the temperature of the concrete being produced. Even in cold climates, if an acceptable concrete working temperature can be obtained using hot water, and provided the concrete is kept insulated, the natural exotherm of the hydration reaction will allow the concrete to gain strength.</p>	<p>P.V-S.18.3.3</p>
<p>Hot Weather Concreting</p> <p>Placing concrete in hot weather can lead to issues with slump loss, plastic shrinkage cracking and potentially thermal cracking. Concrete temperature can be reduced by (a) using blended cements, (b) cooling aggregates, (c) using ice or liquid nitrogen to cool the concrete and (d) by using admixtures.</p>	<p>P.V-S.18.2</p>

<p>Hydration Reaction</p> <p>The hydration of cement forms the basis of conventional concrete technology. Portland cement hydrates (relatively) slowly with the formation of a calcium silicate hydrate gel (that binds the concrete components together) plus lime plus heat (of hydration). The initial dormant phase of this reaction allows time for concrete to be transported to job sites and placed and finished, before the hardening phase causes strength to develop over the following weeks and months.</p>	<p>P.II-S.1.3.2</p>
<p>Hydration Staining</p> <p>Hydration staining is a mottled finish that can appear on the surface of concrete, and particularly concrete cured under plastic sheeting. In areas where the plastic sheeting touches the concrete surface a different colouration is seen compared to areas where the plastic sheeting remains off the concrete surface. The end result is a mottled finish reflecting different W/C ratios in the different areas of the concrete surface.</p>	<p>P.V-S.15.4.2</p>
<p>Hydraulic Cement</p> <p>A hydraulic cement is one that hardens when it reacts with water to form a solid, stable product. The cement combines with the water to form a hydrated compound (e.g. calcium silicate hydrate). The hydration reaction may also occur under water provided the bulk of the concrete mass is protected from exposure to excess water.</p>	<p>P.II-S.1.2.1</p>
<p>Hydrostatic Pressure in Formwork</p> <p>Hydrostatic pressure in formwork results from the force exerted from the plastic concrete which is only partly able to support itself. The hydrostatic pressure increases with the depth of the concrete and can be an issue with deep walls and columns. Where flowing concrete is being used (e.g. Super-Workable Concrete – SWC / Self-Compacting Concrete – SCC), significant lateral pressures are exerted against the formwork, requiring the formwork to be stiffened considerably when SWC/SCC is used.</p>	<p>P.IX-S.27.6.2</p>



<p>Immersion Vibrators</p> <p>An immersion (or 'spud' or 'poker') vibrator is used to compact concrete in a local area – with a radius of action in the range 100-500 mm. They may be used in combination with surface vibrators on slabs and pavements.</p>	<p>P.V-S.13.6.2</p>
<p>In-Situ Concrete</p> <p>Concrete that is cast in a structure or a structural or non-structural element at site.</p>	<p>P.V-S.12</p>
<p>Indirect Tensile Strength Test</p> <p>The Indirect Tensile Strength or Splitting or Brazil test is used to measure the tensile strength of concrete. A test cylinder like that used for compressive strength testing is placed in a rig and a load is applied to the length of the cylinder through two bearing strips. The cylinder splits along its length at failure.</p> <p>See also <i>Brazil Test</i>.</p>	<p>P.VIII-S.25.3.1</p>

<p>Isolation Joints</p> <p>Isolation joints are formed between newly placed concrete slabs (usually slab on ground) and existing structures. The joint is formed with a flexible filler to allow the concrete some movement without damaging the existing structure.</p>	<p>P.V-S.17.4.5</p> <p>P.XI.15.18</p>
---	---

J

<p>J-Ring Test (and L-Box and U-Box Tests)</p> <p>These tests are used to measure the flow of flowing concrete, under its own mass, through various impediments that might be encountered as flowing concrete moves through congested reinforcement or around other structural components.</p>	<p>P.VIII-S.25.2.4</p>
<p>Joints</p> <p>(1) A physical separation in a concrete system, whether precast or cast in-situ, including cracks if intentionally made to occur at specified locations.</p> <p>(2) The region where structural members intersect.</p>	<p>P.I.2.2</p> <p>P.V-S.17.4</p> <p>P.VI-S.20.2.3</p>
<p>Joint Sealants</p> <p>Joint sealants are used to fill the gap between (typically) precast concrete wall panels. These joint sealants must fulfil several functions, including (a) preventing water ingress and (b) maintaining the required fire rating of the structure.</p>	<p>P.V-S.17.4.3</p> <p>P.VI-S.20.2.3</p>
<p>Joint Widths</p> <p>Joint widths are an important aspect of construction using precast (factory-produced or tilt-up) concrete panels in particular. Appropriate joint widths allow for proper sealing between panels and also cater for erection tolerances. The typical joint width between panels is about 15-25 mm, while between panels and cast in-situ elements it is about 150 mm.</p>	<p>P.VI-S.20.2.3</p>
<p>Jump / Climb Forms</p> <p>These are a type of 'gang form' used for casting vertical elements like walls or shafts. Without the use of cranes these forms can be stripped and reassembled in a new position and then aligned in that new position using an in-built jacking system.</p>	<p>P.IX-S.27.5.4</p>

K

<p>Kerb (and Channel)</p> <p>Modifications above and below the surface of a slab such as a road along the outline to separate the concrete structure from soil or other structures such as a pavement.</p>	<p>P.VI-S.19.3.3</p>
---	-----------------------------

<p>Kibble</p> <p>A 'kibble' is a large (1-2 m³ capacity) 'bucket' used on construction sites to move concrete from the transit mixer to the placing area. The kibble is suspended from a crane and moves back and forward between the transit mixer and placing area. This method of delivery is being replaced by pumps, but in some cases is still useful, provided there is sufficient crane time available for this demanding activity.</p>	<p>P.V-S.12.4.4</p>
---	----------------------------

L

<p>Laitance</p> <p>The transportation of fine cement and aggregate particulates toward the surface due to water movement. This occurs due to the presence of too much water in the mixture and is not due to dissolution of salts in the water.</p>	<p>P.V-S.16.4</p>
<p>Lean Concrete</p> <p>Concrete of low cementitious material content.</p>	
<p>LEED Rating System</p> <p>The LEED Rating system is an American sustainability rating system which is sometimes used in Australia. Modern versions of this system use more holistic approaches based on LCA's and product disclosure and optimisation rather than a more simple focus on materials.</p>	<p>P.X.4.4</p>
<p>Life Cycle Assessment (LCA)</p> <p>Life cycle assessment is used to assess the total amount of energy consumed and greenhouse gases emitted in the whole life of a structure – its construction, operation and ultimate demolition. LCA is used to compare the environmental impact of different building materials and designs over the whole of the life of the structure to provide a more realistic comparison of relative environmental performance.</p>	<p>P.X.4.2</p>
<p>Lightweight Aggregate</p> <p>Aggregate of low density such as:</p> <ol style="list-style-type: none"> (1) Expanded or sintered clay, shale, slate, diatomaceous shale, perlite, vermiculite, or slag; (2) Natural pumice, scoria, volcanic cinders, tuff, and diatomite; (3) Sintered fly ash or industrial cinders. <p>Lightweight aggregates are defined by AS 2758.1 as those having a particle density less than 2,100 kg/m³ but not less than 500 kg/m³.</p>	<p>P.II-S.3.2</p>
<p>Lightweight Concrete</p> <p>Concrete of substantially lower density than that made using aggregates of normal density. It consists of either entirely lightweight aggregate or a combination of lightweight aggregate and normal-density aggregate. Its equilibrium densities are generally between 1,100 kg/m³ and 2,000 kg/m³.</p>	<p>P.II-S.3.2</p>

<p>Lime</p> <p>Lime, also known as hydrated lime or calcium hydroxide [Ca(OH)₂], is a by-product of the hydration reaction between (Portland) cement and water. Depending on the cement content, concrete may contain 70 kg of lime per cubic metre. Lime gives concrete its high pH and is primarily responsible for the existence of efflorescence where it occurs. Lime as a separate chemical is also used in cement-based mortar mixes to improve the workability of masonry mortars.</p>	<p>P.II-S.1.3.2</p>
<p>Load Cell</p> <p>A device for measuring force. Generally, the readout is electronic and can be recorded in digital format.</p>	<p>P.V-S.11.6.4</p>
<p>Loss on Ignition (LOI)</p> <p>Loss on Ignition (LOI) tests are used when testing both cements and Supplementary Cementitious Materials (SCM's). This simple test measures weight loss when the sample is heated to levels of 750-950°C. For cement – it provides a measure of chemically absorbed water and CO₂ which can reflect product (cement or clinker) that has been exposed to moisture and/or weather. For SCM's – (a) for fly ash and silica fume it reflects the presence of unburned carbon remaining from their production processes, and (b) for GGBFS it can reflect exposure to weather. (Note: For GGBFS, the LOI value can be negative as certain reduced species react with oxygen during the test and the sample may gain weight as a result.)</p>	<p>P.II-S.1.6.5</p>
<p>Low Heat Cement (Type LH)</p> <p>Type LH cements are typically blended cements and may contain either 40% fly ash or 65% GGBFS. Low heat cements hydrate more slowly and produce lower peak temperatures in concrete structures. They are used in mass concrete structures like concrete dams and mass footings to limit temperature rise and the risk of thermal cracking.</p>	<p>P.II-S.1.2.4</p>

M

<p>Masonry Cement</p> <p>Masonry cements are used in mortar for brick, block and stone construction. They usually contain finely milled blends of cement clinker, limestone, hydrated lime and pozzolans. They may also contain air entraining agents, plasticisers and water repellent materials. Masonry cements are intended to meet the requirements of AS 1316.</p>	<p>P.II-S.1.2.4</p>
<p>Mass Concrete</p> <p>Any volume of structural concrete in which a combination of dimensions of the member being cast, the boundary conditions, the characteristics of the concrete mixture, and the ambient conditions can lead to undesirable thermal stresses, cracking, deleterious chemical reactions, or reduction in the long-term strength as a result of elevated concrete temperature due to heat from cement hydration.</p>	<p>P.V-S.17.4.3 P.V-S.18.2.2 P.V-S.18.2.4</p>

<p>Maturity</p> <p>'Maturity' in concrete terms is a measure used particularly in precast concrete manufacture, to assess likely concrete strength based on the temperatures achieved during the (steam) curing cycle multiplied by the duration of the curing cycle. A maturity value is calculated as [$^{\circ}\text{C} \times \text{time (hours)}$] and correlates well with expected concrete strength for a given mix and curing process.</p>	<p>P.VI-S.20.2.2</p>
<p>Megapascals (MPa)</p> <p>Measure of strength of concrete usually in compression, tension or flexure. It is a force per unit area.</p>	
<p>Membrane</p> <p>A compound formed during curing which solidifies to form a protective sheet material, acting as a barrier to restrict evaporation and to keep excess water from entering the concrete mixture.</p>	<p>P.V-S.15.4.2</p>
<p>Mesh</p> <p>Usually refers to intersecting reinforcing wires within a concrete member. A series of longitudinal and transverse wires arranged approximately at right angles to each other and welded together at all points of intersection.</p>	<p>P.II-S.6.2.3 P.V-S.11.2.1</p>
<p>Metakaolin</p> <p>Metakaolin is an activated kaolin clay that is a highly efficient pozzolan and a suitable material for alkali activation to form a specific type of AAM. The clay mineral kaolin can be heated to about 600-800°C in a kiln to produce an anhydrous, calcined form of the mineral. The fine material is highly reactive and, because of its low temperature calcination, has a low level of embodied carbon dioxide.</p>	<p>P.VII-S.23.5.4</p>
<p>Microstrain</p> <p>Microstrain is most commonly used as the unit that indicates the degree of drying shrinkage in concrete. Microstrain is essentially 'parts per million'. Concrete with a drying shrinkage test result of 850 microstrain has shrinkage of 0.085% or 0.85 mm/m. Concrete drying shrinkage as measured in a laboratory is often at a quite different (and higher) level than that found in the field.</p>	<p>P.VIII-S.25.3.2 P.VIII-S.26.4.6</p>
<p>Milestone</p> <p>Milestones are tools used in project management to mark specific points along a project timeline. These are generally time-based and relate to the critical path of the construction plan.</p>	<p>P.XI.5.1</p>
<p>Mineral Additions</p> <p>Mineral additions are materials that can be added to a cement mill in addition to clinker and gypsum when milling cement. According to AS 3972, allowable mineral additions are either fly ash, GGBFS, limestone or 'minor additional constituents' or a combination of these materials – in most cases up to a maximum of 7.5% by mass. However, no more than 5% 'minor additional constituents' (e.g. cement kiln dust) can be used in any circumstance. The mineral additions are used solely for the purpose of reducing the clinker content of cement with a view to reducing its 'carbon intensity' – but without creating any detrimental effect on cement performance.</p>	<p>P.II-S.1.2.2</p>

<p>Mix Design</p> <p>The optimal design by proportion of ingredients that makes up the most economical use of available materials for concrete of specified properties.</p>	<p>P.III</p>
<p>Mixing Time</p> <p>The time of mixing a concrete batch in a mixer.</p>	<p>P.IV-S.9.2.5</p> <p>P.IV-S.9.3.1</p>
<p>Mixing Water</p> <p>The water present in freshly-mixed mixtures, excluding water that was absorbed by the aggregate.</p>	<p>P.II-S.4.1</p> <p>P.III.2.6</p>

N

<p>Non-Chloride Accelerator</p> <p>To limit the amount of chloride in each cubic metre of concrete, all raw material suppliers ensure that the chloride content of their product(s) do not add substantially to the combined chloride content. A common and effective accelerating admixture used for many years was calcium chloride – a material with a very high chloride content. Admixture producers ensure that they limit the chloride content in their products and now do not use calcium chloride in accelerating admixtures.</p> <p>See also <i>Admixtures</i>.</p>	<p>P.II-S.5.2.3</p>
<p>No Fines Concrete</p> <p>A mixture of concrete which does not contain fine aggregate. This results in an agglomerated structure of coarse aggregate and cement which induces high porosity. Such a high porosity, as a result, allows water to flow through the concrete body.</p> <p>See also <i>Pervious Concrete</i>.</p>	<p>P.VII-S.24.3.5</p>
<p>Normal Class Concrete</p> <p>Concrete that is specified primarily by a standard compressive strength grade up to 50 MPa, has a density of 2,100-2,800 kg/m³ and adheres to the requirements set out in AS 1379.</p>	<p>P.IV-S.8.2.2</p> <p>P.XI.6.1</p>

O

<p>Oil Well Cements</p> <p>Oil Well cements are used in the petroleum industry to grout oil and gas wells. In these applications the grout must remain fluid under high temperatures and pressures for up to several hours and then harden quite rapidly. They are also required to be highly resistant to aggressive agents (e.g. sulfur-containing compounds). These cements are modified general purpose cements which are specifically manufactured for this purpose. The testing and specification of these products falls under the jurisdiction of the American Petroleum Institute (API).</p>	<p>P.II-S.1.2.4</p>
<p>Orimet Test Method</p> <p>The Orimet test is an indirect method that measures the ability of a fluid concrete to flow into a defined space under its own mass.</p>	<p>P.VIII-S.25.2.4</p>
<p>Over-Vibration</p> <p>For well designed, normal weight concretes, over-vibration is rarely a problem. If it was to occur, it would be indicated by segregation and the formation of thick paste layers on the surface of the concrete. Under-vibration is much more likely to be a problem in concrete construction.</p>	<p>P.V-S.13.7</p>

P

<p>Packaged Concrete Mixes</p> <p>Packaged concrete mixes can be bought at hardware stores – typically in 20 kg bags of dry, pre-packaged concrete materials – a ‘just add water’ product. These bags typically make about 10 litres of plastic concrete. These mixes are designed to achieve strengths of around 15 MPa at 7 days when slump is in the range of 75-100 mm but can be quite variable.</p>	<p>P.IV-S.9.3.2</p>
<p>Pattern Paving</p> <p>Pattern paving is a texturing method which can be used to provide a geometric pattern to the surface of concrete for use in driveways and decorative concrete applications. After bull floating the surface is coated with a coloured dry-shake topping and a release agent is applied before the surface is ‘stamped’ with a patterning mould. When this is complete, the surface is cleaned and a light broom finish applied before curing. A sealer can be applied at a later time – but only after the release agent has been washed off.</p>	<p>P.V-S.14.7</p>

<p>Paving Machines</p> <p>Paving machines are large slip-forming operations that are used to place large areas of high quality paving concrete – most typically for concrete roads and for airport pavements. In concrete road construction, paving machines can pave in single-lane or multi-lane formats. These machines take low-slump concrete and compact and finish it in a single pass and can create concrete pavement in several formats including Plain Jointed (PCP), Jointed Reinforced (JRCP) and Continuously Reinforced Concrete Pavement (CRCP).</p>	<p>P.VI-S.19.3.2</p>
<p>Permanent Formwork</p> <p>Permanent formwork is formwork that is left in place to become part of the finished structure. Precast concrete can be used for permanent formwork in situations where some load-bearing capacity is required. Where only decorative capability is required glass reinforced concrete is typically used.</p>	<p>P.IX-S.27.5.6</p>
<p>Permeable Formwork</p> <p>Permeable formwork allows bleed water and air to escape through the formed face of a concrete element. This has several effects, including (a) lowering W/C ratio (to a depth of about 20 mm), (b) improving strength and lowering sorptivity at the formed surface, and (c) improving the surface finish.</p>	<p>P.IX-S.27.3.6</p>
<p>Permeability</p> <p>Permeability of a concrete reflects the ability of fluids (water or gases) to move through the concrete pore structure. While a concrete may have considerable porosity, if the pores are discontinuous it will not be permeable. Permeability is reduced by (a) lowering the W/C ratio (or increasing the cement content), (b) curing and (c) using SCM's. Lower levels of permeability generally mean better durability performance.</p>	<p>P.II-S.1.4.5 P.VIII-S.25.3.2</p>
<p>Permissible Tolerances</p> <p>When batching concrete to meet the requirements of AS 1379, the Standard nominates tolerances of mass above and below the mix design requirements which must be met for all raw materials used in the batch. These tolerances are noted in Table 4.1 in AS 1379.</p>	<p>P.IV-S.9.2.6</p>
<p>Pervious Concrete</p> <p>Pervious or absorbent concrete is effectively a No-Fines concrete. The concrete mix contains only single-sized coarse aggregate and cement paste and as expected, the concrete contains a high proportion of voids. The advantage of this concrete is that water will flow through it. It is used to remove water from large paved areas (e.g. supermarket and airport car parks) where, in a significant rain event, water would pool and cause safety and traffic hazards.</p> <p>See also <i>No Fines Concrete</i>.</p>	<p>P.VII-S.24.3.5</p>

<p>Plastic Concrete</p> <p>Concrete exists in a plastic state for several hours – depending on temperature, cement content and type, presence of admixtures and other factors. This plastic state exists from the time the water is first mixed into the concrete components until it starts to stiffen at about the time it achieves Initial Set. Plastic concrete can be moulded into a vast array of shapes and it is this property particularly that makes it a popular building material. While the concrete has high tensile capacity when ‘plastic’, it has no strength and is prone to certain failure modes including plastic shrinkage cracking and segregation if the mix has not been designed properly or concrete placing does not take account of local environmental conditions. Plastic concrete is also a corrosive material with a high pH and care should be taken in relation to contact of plastic concrete with mucous membranes or bare skin.</p>	<p>P.V-S.13.4 P.IX-S.28.6</p>
<p>Plastic Shrinkage Cracking</p> <p>Plastic shrinkage cracking occurs in plastic concrete when it dries out in the period between bull floating and initial set – a time when the concrete has minimal tensile capacity. Hot weather alone is not the primary cause – rather it is high drying (evaporative) conditions that include high wind speeds, low humidity and high concrete and ambient temperatures. These conditions cause bleed water to evaporate leaving the plastic concrete to dry out and crack like a dry creek bed.</p>	<p>P.V-S.18.2.6</p>
<p>Plastic Settlement Cracking</p> <p>Plastic settlement cracking occurs when plastic concrete settles over obstructions (e.g. reinforcing steel, deeper concrete sections) and effectively bends and breaks across the obstruction. Highly workable or poorly cohesive mixes that demonstrate high levels of settling are prone to this issue. The cracking that occurs is often geometric in pattern reflecting the obstruction below (e.g. the pattern of the reinforcing steel).</p>	<p>P.V-S.17.2.1</p>
<p>Poisson’s Ratio</p> <p>Poisson's Ratio is a measure of the Poisson effect, that describes the expansion or contraction of a material in directions perpendicular to the direction of loading. For small values of these changes, Poisson’s Ratio is the amount of transversal expansion divided by the amount of axial compression (refer to AS 1012.17).</p>	<p>P.VIII-S.26.4.8</p>
<p>Polymer Concrete</p> <p>Polymeric materials, both thermoplastic and thermo-setting types, can be used as complete or partial replacements for Portland cement in the manufacture of concrete. Polymer concrete generally provides high durability performance and is used in specialty applications where specific durability requirements exist (e.g. sewerage systems, concrete repair). The significant advantages of polymer concrete like excellent compressive and tensile strengths, low permeability, lighter weight, good freeze-thaw resistance and good adhesion to a wide range of materials are offset by higher cost.</p>	<p>P.VII-S.24.3.4</p>

<p>Polythene Sheet</p> <p>Polythene sheet is thin plastic sheeting usually used to cover the surface of recently finished concrete to retain moisture while the concrete cures over several days. After finishing, the concrete is moistened and the sheeting is then placed over the concrete surface, ensuring that it does not come loose during the curing period which would allow the concrete surface to dry out. If the sheet is allowed to contact the concrete surface in some places and not in others then a mottling effect (due to different levels of W/C ratio) known as ‘hydration staining’ may be seen when the plastic sheet is removed. Polythene sheet is also used to protect finished work against splashes from other concrete or staining from grout used in subsequent lifts.</p>	<p>P.V-S.15.4.2</p> <p>P.V-S.16.2.6</p>
<p>Portland Cement</p> <p>Portland cement was patented in 1824 in England but the product as we know it was not produced properly until the 1840’s when higher kiln temperatures were able to be achieved. The product was named ‘Portland’ cement because the colour of the product resembled that of stone found in the Portland region in England. Although the modern product is much more efficient, the fundamental mineralogy remains very similar to the original product.</p>	<p>P.II-S.1.2.2</p>
<p>Pozzolan Material / Pozzolan</p> <p>Pozzolans are fine, amorphous materials that, in the presence of water, react with lime produced by cement hydration to form cementitious products. Pozzolans can be substituted for part of the cement component in concrete mixes and are therefore considered to be Supplementary Cementitious Materials (SCM’s). Examples include fly ash, GGBFS and silica fume.</p> <p>See also <i>Supplementary Cementitious Material (SCM)</i>.</p>	<p>P.II-S.2.1</p>
<p>Precast Concrete</p> <p>Concrete that is moulded and cured in a controlled factory environment using advanced manufacturing techniques, and is then transported to site and put into place by a crane or other lifting equipment (refer to ‘Precast Concrete Handbook’ – NPCAA/CIA).</p>	<p>P.VI-S.20</p>
<p>Prestressed Concrete</p> <p>Concrete that has induced internal compressive stresses supplied via incorporated reinforcement tendons (wires, bars), which is used to allow the concrete structure to withstand higher tensile loads (refer to AS 3600–18).</p>	<p>P.I.4</p>
<p>Premixed Concrete</p> <p>In the earliest days of concrete construction, concrete was mixed (often by hand) at the job site. Most often now, pre-mixed concrete is supplied by truck from a dedicated concrete batch plant located (typically) within reasonable proximity of the job site. Typically, this concrete is produced in a ‘dry-batch’ plant – these plants becoming the ‘norm’ in Australia from the late 1950’s.</p>	<p>P.IV-S.9.2</p>

<p>Properties of Concrete</p> <p>Properties of consideration include:</p> <ul style="list-style-type: none"> ● Strength – the ability of concrete to resist strain or rupture induced by external forces. Sub-categories of strength include: <ul style="list-style-type: none"> – Compressive strength – see <i>Compressive Strength</i>; – Fatigue strength – cyclic-stress resistance to strain at stresses lower than the yield strength of concrete; – Flexural strength – see <i>Flexural Strength</i>; – Shear strength – resistance to shear strain under stresses parallel to the concrete surface; – Tensile strength – see <i>Tensile Strength of Concrete</i>; – Ultimate strength – the highest stress achieved for a concrete compression test; – Yield strength – the stress at which concrete begins to plastically deform. This is found in concrete using the 0.2% proof stress technique. ● Porosity – the ratio of the volume of voids in a material to the total material volume (including voids). See also <i>Capillary Porosity (and Capillary Discontinuity)</i>; ● Elasticity – the ease of concrete to deform elastically, referring to the slope of the elastic region of the stress-strain curve. See also <i>Static Chord Modulus of Elasticity</i>; ● Durability – see <i>Durability</i>; ● Workability – see <i>Workability</i>; ● Consistency – see <i>Consistency</i>. 	<p>P.VIII-S.25</p>
<p>Pug Mill</p> <p>A pug mill is a continuous concrete-producing plant in which batching is done by volume rather than by mass. Pug mills are typically used for the production of high volume, lower grade concretes that may be used, for example, for Roller Compacted Concrete construction.</p>	<p>P.IV-S.9.2.5</p>
<p>Pump / Concrete Pump</p> <p>Concrete pumps provide a highly effective way of delivering concrete to job sites of all types. They are useful in domestic construction to deliver from the road to the house slab, and equally effective when used in high-rise construction. A pump should be chosen on the basis of required delivery rate and suitability for the site. Multiple pumps may be required on some job sites. While they are highly effective, pumps also bring some safety issues in terms of their operation and maintenance and potential congestion of sites with delivery vehicles queuing for access to the pump(s). There are two basic pump types – piston pumps and peristaltic (or squeeze) pumps.</p>	<p>P.IV-S.10.4.1 P.V-S.12.4.6</p>

Q

<p>Quenched and Tempered Wire</p> <p>Quenching and tempering are processes that strengthen and harden steel. The process of quenching or quench hardening involves heating the steel wire and then rapidly cooling it. This process is used in certain higher strength prestress wires.</p>	<p>P.II-S.6.2.2</p>
--	----------------------------

R

<p>Reactive Powder Concrete</p> <p>Reactive powder concrete is an ultra-high strength concrete product produced using very high cement and silica fume contents and at very low W/C ratios through the use of High Range Super-plasticisers. The mixes take a long time and considerable effort to produce. The principal use of this type of concrete is in very high strength applications – with strengths of >200 MPa being able to be achieved.</p> <p>See also <i>High Strength / Ultra High Strength Concrete</i>.</p>	<p>P.VII-S.24.3.3</p>
<p>Recycled Water (as Mixing Water)</p> <p>Water recycled within a concrete plant is able to be used as mixing water provided that it is stored in a manner that prevents it becoming contaminated with deleterious substances and the water meets the quality requirements described in AS 1379.</p> <p>See also <i>Water Quality (Mixing Water)</i>.</p>	<p>P.II-S.4.3.4</p>
<p>Reinforced Concrete</p> <p>Structural concrete reinforced with no less than the minimum amount of prestressing steel or non-prestressed reinforcement as specified from design using the applicable building code (see also ACI CT-18).</p>	<p>P.I.3</p>
<p>Reinforcement</p> <p>Bars, wires, strands, fibres or other slender elements that are embedded in concrete in such a manner that the two materials act together in resisting forces (see also ACI CT-18).</p>	<p>P.II-S.6 P.V-S.11</p>
<p>Release Agent</p> <p>Release agents are used to ensure good separation of formwork away from the formed face of concrete when removing formwork so that the surface finish is both even and undamaged. Where high quality surface finishes are required, the type of release agent and its rate of application are key control areas. In these cases (a) the same release agent should be used throughout the project, and (b) the release agent should be applied uniformly at the minimum rate consistent with full coverage and any excess should be removed prior to concreting.</p>	<p>P.V-S.16.2.3 P.IX-S.27.8.2</p>
<p>Relative Water Requirement</p> <p>Relative Water Requirement (RWR) is a test used to assess the effect of an SCM on workability. It is a mortar test in which the flow of a mortar containing an SCM as a partial cement replacement is compared with the flow of a cement-only mortar. The result is expressed as a %. This result cannot be transposed to concrete mixes to provide an estimate of potential water reduction, nor can results from tests involving different SCM sources or different SCM types be compared.</p>	<p>P.II-S.2.6.4</p>
<p>Reshoring</p> <p>Reshoring is the process of removing a section of the formwork and supporting structure and then replacing the supporting structure after the formwork has been removed.</p>	<p>P.IX-S.27.7.3</p>

<p>Respirable Dust</p> <p>Respirable dust is very fine particulate material that can be breathed in and penetrate deep into the lungs which can cause complaints with variable severity. Respirable dust is generally considered to be those with a diameter of <10 µm. For dusts that have high potential to affect human health, exposure limits have been set by regulatory authorities and testing to assess workplace levels should be carried out from time to time. From a concrete perspective, dusts of concern include those from cement, fly ash, GGBFS, silica fume, siliceous aggregates and concrete (e.g. when cutting concrete with a saw or breaking concrete during demolition). Dusts containing crystalline silica are of particular concern if there is repeated or ongoing exposure.</p>	<p>P.IX-S.28.3.2</p>
<p>Rheology of Concrete</p> <p>A term used to describe the combined consistency and workability in concrete. Measured using the Yield Stress and Plastic Viscosity properties of concrete. While a useful tool for describing all concrete mixtures, this is particularly useful in describing Super-Workable Concrete.</p>	<p>P.VI-S.22.3.2</p>
<p>RILEM</p> <p>RILEM is the International Union of Laboratories and Experts in Construction Materials, Systems and Structures. This European committee is currently working (amongst other things) on developing Standards and specifications for AAM's and concrete produced using AAM binders, as well as developing appropriate test methods for the materials.</p> <p>See also <i>Geopolymers</i> and <i>Alkali Activated Materials (AAM's)</i>.</p>	<p>P.VII-S23.6</p>
<p>Roller Compacted Concrete (RCC)</p> <p>Roller compacted concrete (RCC) is most commonly used in the construction of dams where high volumes of lower grade (e.g. 10 MPa at 28, 56 or 90-days) are placed virtually continuously and in lifts of about 300 mm thickness. The concrete is produced in a pug mill and the low slump mix is often delivered to the placing site by tipper or conveyor before being compacted by a variety of mobile 'roller-type' machines. RCC mix designs may vary from low cementitious (60 kg.m⁻³) to high cementitious (200 kg.m⁻³) contents, with strengths and permeability varying accordingly. In another form, RCC may be used for road pavements or hardstand construction where the wearing layer has typical 28-day compressive strengths of about 40 MPa. The advantage of all types of RCC is their rapid production and placing rates.</p>	<p>P.IV-S.10.4.1</p>

S

<p>Safety Data Sheets (SDS)</p> <p>All hazardous materials used in any workplace must have a Safety Data Sheet (SDS) and these SDS must be collated and made available to workers who might use the hazardous material(s). SDS must be supplied to users by the supplier of the product of the manufacturer and they must contain contact details for (a) the manufacturer and (b) a Poisons Information centre or similar. SDS must have current information, be dated and be reviewed each 5 years as a minimum. SDS must contain information about chemical constituents of a product and relevant information relating to first aid, health risks, physical and chemical properties and environmental risks.</p>	<p>P.IX-S.28.3.1</p>
---	-----------------------------

<p>Sand Moisture Test</p> <p>A test used to assess the moisture content of sand. There are many methods, but the most common method is by oven drying of a sand sample to AS 1141.5. There are other tests using different drying methods and some chemical methods to determine the free water in sand.</p>	<p>P.II-S.3.4.4</p>
<p>Saturated Surface Dry (SSD)</p> <p>State of an aggregate particle when the interior, permeable pores are filled with water and no water is on the exposed surface of the particle (see also ACI CT-18).</p>	<p>P.II-S.3.4.4 P.III.2.8</p>
<p>Screed</p> <p>A screed is a thin concrete topping that may be placed over a defective concrete surface. Screeds can be 'bonded' or 'unbonded'. 'Bonded' screeds are thin toppings that are bonded to the underlying surface with an adhesive. 'Unbonded' screeds tend to be thicker layers of concrete, and typically are jointed. Joints need to match any joints in the underlying surface or reflective cracking will be seen in the new screed.</p> <p>See also <i>Screeding</i>.</p>	<p>P.V-S.14</p>
<p>Screeding</p> <p>Screeding or levelling is the first operation carried out when finishing concrete. Screeding establishes the level of the concrete surface against the forms after the plastic concrete has been roughly levelled by shovel or similar. Screeding may be done using a screed board worked in a sawing motion across the forms, or by a mechanised vibrating screed. In large area projects (e.g. factory floors) a 'laser screed' may also be used to establish highly accurate slab heights and levels.</p>	<p>P.V-S.14.3</p>
<p>Segmental Construction</p> <p>Segmental construction is defined as a method of construction for bridges, buildings, tanks, tunnels, and other structures in which primary load carrying members are composed of individual segments post-tensioned together.</p>	<p>P.I.4.4</p>
<p>Segregation</p> <p>Segregation is separation of the coarse aggregate from the mortar in concrete. A segregated concrete mix will not achieve its performance requirements and will generally result in a non-uniform concrete containing porous and honey-combed areas. Segregation can be avoided by having a well-mixed, cohesive mix.</p>	<p>P.V-S.12.2.2 P.VIII-S.25.2.3</p>
<p>Self-Compacting Concrete (SCC) or Super-Workable Concrete (SWC)</p> <p>Self-Compacting Concrete (SCC) or Super-Workable Concrete (SWC) has been in use for a number of years and its use is continually growing. SCC/SWC allows the placement of high strength/ low W/C ratio concrete mixes in a range of demanding situations. Its benefits accrue through properties that include its resistance to segregation, the ability to place SCC/SWC in areas of congested reinforcement and the ability to create high quality off-form finishes.</p>	<p>P.VI-S.22 P.VII-S.24.3.1</p>
<p>Self-Curing Concrete</p> <p>Self-curing concrete contains either (a) polymeric materials that combine with the water in concrete and prevent it from evaporating from any exposed concrete surface, or (b) saturated porous aggregates that provide water for ongoing hydration after the concrete has hardened. In both cases the materials need to be added to the concrete at the time of manufacture.</p>	<p>P.VII-S.24.3.7</p>

<p>Self-Healing Concrete</p> <p>Self-healing concrete contains materials that react with any water ingress through cracks in the concrete to effectively seal the cracks. The concrete can contain polymeric materials or 'hydro-gels' (or in a more recent version a bacterium) that are activated by water and produce an expansive product that seals the cracks. These materials need to be added to the concrete at the time of manufacture.</p>	<p>P.VII-S.24.3.6</p>
<p>Setting Time</p> <p>The setting time for paste, mortar and concrete is one of the most important parameters from a practical perspective. Laboratory-based setting time tests are used to determine 'initial' and 'final' setting times and limit values for these times feature in most relevant Standards. In the field, setting time is of critical importance. While setting time can be manipulated to a degree by using accelerating and retarding admixtures, other factors also determine the working time available to concrete placers, bricklayers etc. Setting that is too fast or too slow has serious ramifications for those trades using cement-based products.</p>	<p>P.II-S.1.4.1</p>
<p>Shear Stress</p> <p>Shear stress is a force per unit area that causes layers or parts to slide upon each other in opposite directions. These stresses are more significant in concrete structure near the points of loading (e.g. beam or slab intersections with columns).</p>	<p>P.I.3.2</p>
<p>Shewhart Chart</p> <p>A quality control charting method used to assess variation in measured properties from a target average value. The method includes statistically based limits above and below the target average for individual test results or running averages of test results (refer to AS/NZS 3944).</p>	<p>P.VIII-S.26.5.6</p>
<p>Shoring</p> <p>Shoring is the process of temporarily supporting a building or structure with shores (also known as props) to prevent it from collapsing during construction or renovation.</p>	<p>P.IX-S.27.7.1</p>
<p>Shotcrete</p> <p>Concrete placed via high velocity projection from a nozzle (see also ACI CT-18).</p>	<p>P.II-S.5.2.3 P.II-S.5.2.5</p>
<p>Shrinkage</p> <p>'Shrinkage' is an issue for all cement-based products. To achieve workability, the amount of water required is in excess of that required just for hydration of the cement, and once the cement-based product hardens, some of that excess water will evaporate from the paste part of the mortar or concrete. This evaporation leads to drying shrinkage.</p> <p>See also <i>Autogenous Shrinkage</i>.</p>	<p>P.II-S.1.4.4 P.VIII-S.25.3.2</p>
<p>Shrinkage Limited Cement (Type SL)</p> <p>Shrinkage Limited cement may be either a GP or a GB cement. If it is a GP cement it will often be a more coarsely ground cement than typical GP cement. If it is a GB cement then it might typically contain 25% fly ash or 65% GGBFS. The test for a Type SL cement is a laboratory-based mortar bar test that is conducted for a period of 28 days.</p>	<p>P.II-S.1.2.4</p>

<p>Silica Fume</p> <p>Silica fume is an ultra-fine material emitted from arc furnaces processing silicon metal or ferro-silicon alloys. Typically, this material has a particle size of 0.1-0.2 µm and a surface area of about 20,000 m²/kg and an SG of about 2.1. As produced, it has a low bulk density and is difficult to handle, and densified products or slurries are more commonly used. Silica fume is a pozzolanic material that imparts excellent strength and durability performance to concrete.</p> <p>See also <i>Amorphous Silica</i>.</p>	<p>P.II-S.2.8</p>
<p>Skim Coat</p> <p>A skim coat is a fine finishing coat applied to a concrete or plasterboard wall and provides a finely finished surface. The skim coat may be a cement-based render or a plaster-based material. Skim coats are often applied to new structures (e.g. walls etc.). Skim coats are sometimes applied to slip-formed structures if a fine finish is required.</p>	<p>P.VI-S.19.2.4</p>
<p>Slag</p> <p>'Slags' are produced as waste streams from all mineral processing systems where molten metal products are produced. Slags contain any non-metallic geological material contained in the ore as well as any additives added to improve the efficiency of the process. In iron blast furnaces, the slag contains non-metallic geological material plus limestone which is added to reduce the melting point of the materials charged into the blast furnace. Slags are 'tapped off' and separated from the molten metal product. They may then be either (a) air-cooled or (b) 'quenched' to form a glassy 'granulated slag' product.</p> <p>See also <i>GGBFS</i>.</p>	<p>P.II-S.2.7.1</p>
<p>Slag Aggregate</p> <p>Slag aggregate is formed from the air-cooled slag 'tapped off' from an iron blast furnace. The massive material is crushed and screened like a conventional aggregate to produce a range of aggregate products.</p>	<p>P.II-S.2.7.3 P.II-S.3</p>
<p>Slip Forms</p> <p>Slip forms are forms which are continuously moving – either in the vertical or horizontal direction and are used to cast a variety of structures. Vertical slip-forming is used to create structures like chimneys and deep-sea oil platforms; while horizontal slip-forming is used to create structures like kerb and road barriers.</p>	<p>P.VI-S.19 P.IX-S.27.5.5</p>
<p>Slump</p> <p>See <i>Slump Test (Slump Cone)</i>.</p>	<p>P.VIII-S.25.2.4 P.VIII-S.26.3.2 P.XI.9.1</p>

<p>Slump Flow</p> <p>The Slump Flow Test is applied to flowing (or Self-Compacting or Super-Workable) concretes. The concrete is placed in a standard slump cone and the cone is lifted, allowing the concrete to 'spread'. The diameter of the slumped or spread concrete is a measure of the workability of the mix. A typical spread diameter might be between 500 mm and 800 mm. The cohesiveness of the mix can also be determined from this test. Ideally the concrete remains consistent in composition across the whole spread sample – i.e. the mortar and the aggregate are evenly distributed across the whole sample and not separated or segregated.</p> <p>See also <i>Spread Test</i>.</p>	<p>P.VI-S.22.5.2</p> <p>P.VIII-S.25.2.4</p>
<p>Slump Test (Slump Cone)</p> <p>A test used to measure the consistency of freshly mixed concrete performed using a slump cone. This is done as follows:</p> <ul style="list-style-type: none"> • The cone is filled in three layers. For each layer, a tamping rod is used to compact the concrete by poking the concrete 25 times (for each layer); • The cone is removed, and the concrete is allowed to slump. The height difference between the cone and the slump is measured as the 'concrete slump'. 	<p>P.VIII-S.25.2.4</p> <p>P.VIII-S.26.3.2</p>
<p>Slurry Mix</p> <p>A mixture of water and any finely divided insoluble material, such as Portland Cement, slag or clay in suspension (see also ACI CT-18).</p>	<p>P.V-S.12.4.6</p> <p>P.V-S.16.2.2</p> <p>P.VI-S.19.3.4</p>
<p>Soffit Forms (and Falsework)</p> <p>Formwork and falsework used to support plastic concrete when suspended slabs are cast.</p>	<p>P.IX-S.27.3.1</p>
<p>Sorptivity (or Absorptivity) of Concrete</p> <p>The sorptivity of concrete is a measure of the amount of water (or other liquid) that a concrete will absorb when immersed in it. This property is affected by the porosity of the concrete and also depends on the degree of inter-connectedness of the pores.</p>	<p>P.VIII-S.25.3.2</p>
<p>Soundness</p> <p>It is important that once a cement paste hardens it does not undergo any large changes in volume – particularly any expansions which will increase internal tensile stresses and lead to cracking. There are a couple of minerals which, if present in cement paste, can slowly hydrate and expand, causing the mortar/concrete to crack – or to become 'unsound'. These minerals are (a) Free Lime (CaO) which may be present in cement if it is not fully reacted to form calcium silicate minerals, or (b) periclase (MgO) – a mineral that is found in nature and may be present in either cement clinker or in some SCM's. Free lime levels are monitored by cement producers. MgO levels in clinker (and in some SCM's) are also tested and limits are set.</p>	<p>P.II-S.1.6.2</p>
<p>Special Class Concrete</p> <p>Concrete made with properties and materials that deviate from the attributes of normal-class concrete. It is used for special applications (refer to AS 1379-2007 and AS 3600-18). Examples of special class concretes can be found in Part VI, Sections 19-22 of this Guide.</p>	<p>P.IV-S.8.2.3</p> <p>P.VIII-S.26.6.1</p> <p>P.XI.6.1</p>

<p>Special Purpose Cements (Types HE, SL, SR, LH)</p> <p>Special purpose cements as defined in AS 3972 may be either general purpose cement or a blended cement – provided they meet the performance requirements for each as detailed in Table 2 of AS 3972.</p> <p>See also <i>High Early Strength Cement (Type HE)</i>, <i>Shrinkage Limited Cement (Type SL)</i>, <i>Sulfate Resisting Cement (Type SR)</i> and <i>Low Heat Cement (Type LH)</i>.</p>	<p>P.II.S.1.2.1</p>
<p>Spread Test</p> <p>The Spread Test is the simplest test used to measure the flow characteristics of Super-Workable Concrete mixes. The test uses the normal Slump Cone. After the cone is filled with the concrete mix it is raised to allow the flowable concrete to 'spread' out on a mat on which circles of specific diameters have been drawn. The average maximum spread of the concrete is measured and recorded. The test can also be used to measure the time taken for the concrete to flow to a specific diameter (e.g. 500 mm) and the final concrete can also be examined to determine whether any segregation has occurred during the testing process. A typical 'spread diameter' would be 600 mm.</p> <p>See also <i>Slump Flow</i>.</p>	<p>P.II-S.5.2.4</p>
<p>Stage Stressing</p> <p>Stage stressing is stressing of post-tension tendons at different times instead of stressing at one time. The value of this planned/designed technique is to ensure that the level of post-tension stress in concrete members is only that required to adjust the structure for changes in loading or stresses from other parts of the structure.</p>	<p>P.I.4.4</p>
<p>Standards Australia</p> <p>A national Australian organisation which publishes standards for concrete specifications (and other matters). These Standards set the minimum requirement for performance properties for concrete and concrete materials, and also describe concrete plant performance requirements. Separate Standards also describe rules for the design and detailing of concrete structures.</p> <p>See also <i>Australian Standards</i>.</p>	
<p>Static Chord Modulus of Elasticity</p> <p>The chord modulus is a specific method of test where a defined straight line is used to assess a value of elastic modulus. In the case of AS 1012.17, the line (or chord) starts at a low load that produces a strain of 50 microstrain in the concrete test specimen and the final point on the stress/strain curve is the strain at a load equivalent to 40% of the ultimate compressive strength of the concrete being assessed. The slope of the line between these points is calculated as the static chord modulus of elasticity. It will generally be a lower value than some other methods of assessing elastic modulus (sonic pulse velocity or tangent modulus) but is more reflecting the stress-strain relationship in structural concrete designed in accordance with AS 3600 (refer to AS 1012.17).</p> <p>See also <i>Elastic Modulus</i>.</p>	<p>P.VIII-S.26.4.8</p>

<p>Steam Curing</p> <p>The rate of strength growth of concrete can be increased by increasing the temperature of the concrete, and one way this is done in practice is by steam curing. Steam curing of concrete involves the application of saturated steam to concrete, in a chamber or under covers. Steam curing is routinely used in the manufacture of precast concrete elements. Steam curing is a multi-stage process that has to be highly controlled to achieve optimum concrete strengths and economic efficiency.</p> <p>See also <i>Curing and Heat Accelerated Curing</i>.</p>	<p>P.V-S.15.4.4</p> <p>P.VI-S.20.2.2</p>
<p>Strength Development (Rate of)</p> <p>The rate of development of compressive strength when a cement hydrates is dependent on several factors. For a Type GP cement, it depends on the mineral composition and the fineness of the cement. For a Type GB cement, it depends in part on the proportion of SCM in the blended cement. In both cases it also depends on the W/C ratio and temperature.</p>	<p>P.II-S.1.4.3</p>
<p>Strength Index</p> <p>Strength Index is a test applied to assess the strength performance of SCM's. A mortar containing a proportion of SCM as a cement replacement is prepared and tested for compressive strength. A control mortar containing cement-only is prepared and similarly tested. The ratio of the strength of the SCM-containing mortar to the Control mortar, expressed as a %, is the Strength Index. The Strength Index cannot be used to quantitatively express the cement-replacing capacity of the SCM.</p>	<p>P.II-S.2.6.4</p>
<p>Stripping Times</p> <p>Minimum stripping times for formwork are important with respect to ensuring (a) safety, and (b) concrete quality. Minimum stripping times for in-situ concrete are given in both AS 3600 and AS 3610.1. In a worst-case scenario, if forms are stripped too soon the concrete element may not be properly self-supporting and may collapse. In general, early stripping of formwork from the formed surface of the concrete may cause the concrete surface to be damaged.</p> <p>See also <i>Formwork Stripping</i>.</p>	<p>P.IX-S.27.8.4</p>
<p>Standard Deviation (SD)</p> <p>A statistical measurement of the amount of variation or dispersion of a set of data values from the Mean value in a Normal Distribution.</p>	<p>P.III.2.4</p> <p>P.VIII-S.25.3.1</p> <p>P.VIII-S.26.5.3</p>
<p>Storing Cement and SCM's</p> <p>Cement and SCM's are supplied as fine, dry powders. In this dry state, these powders flow easily and can be transported and transferred between storage vessels quickly and easily. If these powders come into contact with water/moisture, their flow characteristics quickly change. Moisture contents as low as 0.5% can cause this change. Cement and SCM's with higher moisture contents quickly form lumps and these lumps (in addition to the reduced inherent flow characteristics) will cause major issues when transferring the products – especially between silos and weigh hoppers in concrete batch plants.</p>	<p>P.II-S.1.5.1</p>
<p>Strength Grade</p> <p>Numerical value of the characteristic compressive strength of concrete at 28-days used in design (see also AS 3600-18).</p>	<p>P.IV-S.8.2</p> <p>P.VIII-S.25.3.1</p> <p>P.VIII-S.26.5</p>

<p>Strongbacks</p> <p>Strongbacks are external reinforcing structures that are used to support odd-shaped precast elements when they are being lifted into position in a building. They are used with long, thin precast elements or where the shape of an element is such that some part of it may bend or flex significantly while it is being lifted. The strongbacks are attached to the building element during lifting and then removed once the element is in place.</p>	<p>P.VI-S.20.7.4</p>
<p>Studs or Joists</p> <p>Studs or joists are lengths of sawn timber or metal sections that support concrete formwork and prevent it from bowing in one direction.</p>	<p>P.IX-S.27.2</p>
<p>Sub-base</p> <p>The subbase is the layer of aggregate material ('road-base') laid on the subgrade (or local soil rock) to assist with distribution of pavement loads to the subgrade and provide a stronger foundation for the surface material (i.e. the Base-course, Concrete, Asphalt or Pavers).</p>	<p>P.I.2</p>
<p>Surface Defects – Precast Concrete</p> <p>Surface defects in concrete, and particularly precast concrete, are outlined in Tables 16.2 and 16.3 of Part V-Section 16 of this Guide.</p>	<p>P.V-S.16.4</p>
<p>Surface Vibrators</p> <p>Surface vibrators are used to compact concrete – particularly slabs and pavement. They are applied at the surface and act downwards. Typical devices are vibrating beam screeds (single or double beam) – from 3 m to 20 m in width – that may be either manually moved along the slab or motorised. The compaction forces act from the top and have a depth limitation of about 200 mm. They are used in conjunction with immersion vibrators at the edges of slabs where the surface vibration forces are less effective.</p> <p>See also <i>Screed</i> and <i>Screeding</i>.</p>	<p>P.V-S.13.6.3</p>
<p>Sulfates</p> <p>Sulfates are important components in concrete raw materials and important to concrete technology generally. The sulfate content of cement and SCM's is limited in the relevant Standards as sulfates have a tendency to form expansive reaction products within concrete (e.g. by reaction with lime) and cause concrete cracking. Sulfates in the environment (e.g. in sea water, soils and groundwaters) may attack solid concrete and cause it to crack or disintegrate. Sulfate is added to clinker when milling cement to prevent Flash Setting.</p> <p>See also <i>Flash Setting</i>.</p>	<p>P.II-S.2.6.4 P.VIII-S.25.3.2</p>
<p>Sulfate Resisting Cement (Type SR)</p> <p>Sulfate Resisting (Type SR) cements as defined in AS 3972 may be either general purpose cement or blended cement. Typically, a blended Type SR cement will contain either 25% fly ash or 65% GGBFS. There is some contention about using general purpose cements in sulfate-resisting applications, and generally only blended cements would be used if they are available.</p>	<p>P.II-S.1.2.4</p>

<p>Super-Sulfated Slag Cement</p> <p>Super-sulfated slag cements are a binder type in which the main ingredient is ground granulated slag which is activated by a sulfate compound or blend of sulfates – commonly gypsum and sodium or potassium sulfate. These cements also typically contain about 10% of Portland cement to provide early-age strength. Concrete produced using super-sulfated slag generally shows good strength and durability performance and is reported to show low levels of drying shrinkage. A concrete type using this binder system has been commercialised in Australia. The product is known as <i>Envisia™</i>.</p>	<p>P.VII-S.23.4</p>
<p>Superplasticiser</p> <p>Superplasticisers or High Range Water Reducers are now commonly used concrete admixtures. They are able to effect water reduction of up to 25% which allows concrete mixes with very low W/C ratios (about 0.3) to be produced with high levels of workability. The levels of workability possible extend to the creation of flowing, super-workable concrete (SWC) mixes with Spread Test values of up to 700 mm. The latest version of these admixtures is the PCE's (poly-carboxylate ethers) which can be formulated to provide tailored performance characteristics.</p>	<p>P.II-S.5.2.4</p>
<p>Supplementary Cementitious Material (SCM)</p> <p>SCM's are materials that can substitute for cement in a concrete mix and produce reasonably equivalent strength performance and often much improved durability performance. In some cases, they are 'waste' materials (e.g. fly ash, GGBFS and silica fume), and in others they are intentionally produced (e.g. meta-kaolin). Most are pozzolans – that is, they react with the lime produced by cement hydration to form cementitious products similar to those produced by cement hydration.</p> <p>See also <i>Pozzolan Material / Pozzolan</i>.</p>	<p>P.II-S.2.1</p> <p>P.XI.7.2</p>

T

<p>Table Forms</p> <p>Table forms are a type of 'gang form' used to form soffits. Large sections of soffit form (including required props and bracing) can be assembled and then used, moved to another area (by crane or transporter), and used again. The use of table forms helps to improve construction efficiency.</p>	<p>P.IX-S.27.5.3</p>
<p>Target Strength</p> <p>When carrying out a concrete mix design, the mix designer uses a strength that is referred to as the 'Target Strength' of the mix being designed or supplied. It is different from both the characteristic strength and the average strength of the test sample population. In general, its value is more an 'intended' average strength for the mix design and in general it will be either equal to or greater than the average compressive strength.</p>	<p>P.III.2.4</p> <p>P.III.2.5</p> <p>P.VIII-S.26.5</p>

<p>Tensile Strength of Concrete</p> <p>The tensile strength of concrete is considerably lower than the compressive strength – usually by a factor of about 10. Testing a concrete sample involves the application of direct or indirect tensile stress on a sample. The most common test methods are (1) the Indirect or Splitting or Brazil test, or (2) testing a beam in flexure (Flexural Strength Test).</p> <p>See also <i>Indirect Tensile Strength Test, Brazil Test and Flexural Tensile Strength Test or Modulus of Rupture Test.</i></p>	<p>P.VIII-S.25.3.1</p>
<p>Tensile Stress</p> <p>Tensile stress is stress applied to a structural element in a direction that is parallel to the applied force and the forces at either end of the element are trying to pull the element apart.</p>	<p>P.I.3.2</p>
<p>Thermal Movement of Concrete</p> <p>Concrete moves with changes in temperature – expanding when heated and contracting when cooled. The movement is not great – in the range of about 5-12 microstrain/°C – depending in part on the type of aggregate used.</p>	<p>P.V-S.17.3.3 P.VIII-S.25.3.2</p>
<p>Three-Dimensional (3-D) Concrete Printing</p> <p>Three-dimensional or 3-D Concrete Printing is a development involving the integration of robotics and concrete technology. Arguably, any design that can be converted into a computer file and loaded into a robot can be converted into a structure – provided the concrete technology issues can be overcome. There have been huge advances in this area of research and some quite complex structures have been created – simple housing, small bridges and pieces of art – all created using concrete with no (or little) manual input into the construction. Interest from the military and from agencies like NASA indicates that there will be huge advances in this technology over the very near future.</p>	<p>P.VII-S.24.3.10</p>
<p>Tilt-up</p> <p>Tilt-up construction involves the casting of concrete elements – typically wall panels – in a location adjacent to where they will be used in a structure. Once the panels have sufficient strength they are lifted by crane into position in the structure. Tilt-up panels are cast onto a base slab, singly or in layers – with bond breakers used to ensure that the panels can be separated when required.</p>	<p>P.VI-S.20.2.3</p>
<p>Topping</p> <p>A layer of concrete, mortar or mixture placed to form a floor or roofing surface on top of a concrete base.</p> <p>See also <i>Abrasion Resistance, Dry-Shake Toppings (and Driers), Granolithic Topping (Grano), Pattern Paving and Screed.</i></p>	<p>P.V-S.14.7</p>

<p>Transit Mixer</p> <p>Transit mixers are concrete trucks – colloquially known as ‘agitators’ – which are used to mix concrete prior to delivery of the plastic concrete to the job site. At a dry-batch plant, the dry concrete raw materials (plus water and admixtures) are accurately batched into the mixing bowl on the transit mixer and the bowl is rotated to mix the concrete components. When mixing is complete the concrete is tested before delivery to the job site. At the job site the direction of rotation of the bowl is reversed, and the concrete is discharged into the chute or pump or other receiving system.</p> <p>See also <i>Agitator</i>, <i>Agitator Truck</i> and <i>Dry-Batch Plant</i>.</p>	<p>P.IV-S.9.2.5</p>
<p>Translucent Concrete</p> <p>Translucent concrete is concrete that allows some degree of light penetration, which can be formed in two ways. In one, optical fibres are included in the concrete mix and these align to a degree to allow some light to pass through the concrete. In another process, layers of thin translucent fabric are cast within the concrete. This process delivers little or no detriment to strength performance but provides visibility of both form and colour through concrete panels.</p>	<p>P.VII-S.24.3.8</p>
<p>Tremie Concrete</p> <p>Tremie concrete refers to the delivery of concrete to a location using a hopper to hold the mass of concrete and a long pipe to deliver the concrete to the final position. The pipe is lowered to the bottom of the hole or area to be filled and as concrete is passed down the pipe, the pipe is slowly withdrawn, ensuring that the end of the pipe remains (about 1 metre deep) within the body of the concrete. Concrete can be placed under-water using this technique.</p>	<p>P.V-S.12.4.5</p> <p>P.VI-S.21</p>
<p>Trench Mesh</p> <p>Trench Mesh is a Class L and N reinforcing mesh typically used in residential and industrial buildings to reinforce smaller concrete footings and beams.</p>	<p>P.II-S.6.2.3</p>
<p>Trowelling</p> <p>Trowelling is a multi-step task in which a concrete surface is further densified and a final finish created. (This assumes a textured finish like a broom finish is not required.) Trowelling may be by hand or by machine and as the process progresses, increasing effort is applied to achieve the final finish through increasing the surface densification with resulting increased smoothness and wear resistance.</p>	<p>P.V-S.14.5</p>

U

<p>Ultrasonic Pulse Velocity (UPV)</p> <p>UPV is a field test used to assess the quality of concrete and other solid/mass materials (e.g. rocks) in a non-destructive manner. The test measures the velocity of an ultrasonic pulse passing through the solid body, by which the quality of the object (e.g. strength, homogeneity etc.) can be evaluated. Higher velocity generally means better quality.</p>	
---	--

V

<p>Vebe Test</p> <p>A test for measuring workability of very low-slump to 'no-slump' concrete that determines the time required for the concrete sample to be consolidated into a mould. The Vebe Test measures the consistency of concrete by a method that is not dissimilar to the processes used when placing concrete. It is most useful for laboratory determinations with dry mixes (refer also to ACI CT-18).</p>	<p>P.VIII-S.25.2.4 P.VIII-S.26.3.4</p>
<p>Vibration</p> <p>Agitation of freshly mixed concrete during placement by mechanical devices, either pneumatic or electric, that creates impulses of moderately high frequency to assist in concrete consolidation in the mould. This can be done externally, internally or on the surface depending on the thickness of the concrete form and the desired outcome.</p> <p>See also <i>Compaction, External Vibration, Form Vibrators, Immersion Vibrators and Surface Vibrators</i>.</p>	<p>P.V-S.13.6</p>
<p>Visual Stability Index (VSI)</p> <p>The VSI is established by observing the final concrete sample after the Slump Flow Test. The range is from '0' for highly stable to '3' for unacceptable. Ideally the spread mix shows no signs of bleed water around the outer edges or uneven distribution of aggregate – i.e. no signs of segregation.</p>	<p>P.VIII-S.25.2.4</p>

W

<p>Walers or Bearers</p> <p>These brace the studs or support the joists which hold formwork in place and prevent it from bulging in the opposite direction to that which is constrained by the studs or joists.</p>	<p>P.IX-S.27.2</p>
<p>Wall Forms</p> <p>Formwork that is used to support concrete walls when they are cast.</p>	<p>P.IX-S.27.3.1</p>
<p>Water/Cement Ratio (W/C Ratio)</p> <p>The W/C ratio of concrete is calculated by dividing the mass of (free) water by the mass of cementitious material. The W/C ratio is a fundamental determinant of many concrete performance attributes including strength and durability. The typical range of W/C ratios in conventional concretes is about 0.3-0.75, though this range can be extended through the use of admixtures and for some special purpose concrete materials [e.g. Roller Compacted Concrete (RCC)] (see also ACI CT-18).</p>	<p>P.II-S.4.5 P.III.2.5 P.VIII-S.25.3.1 P.VIII-S.25.3.2</p>

<p>Water Density and Mix Design</p> <p>The W/C ratio is fundamental in concrete technology. It is calculated by dividing the mass of water by the mass of cementitious material. The typical range of W/C ratio in conventional concretes is about 0.3-0.75. These figures suggest that the quantity of water is much less than that of cement, and by mass it is. In volume terms though, the situation is very different – and relative volume more accurately reflects cement reaction potential. For a mix with a W/C ratio of 0.6 – say 180 L water and 300 kg of cement – in volume terms there is 180 L/m³ of water, but only 95 L/m³ of cement. The water is in significant excess in volume terms. This is due to the difference in SG of the two materials. Water SG = 1.00 and cement SG = 3.15.</p>	<p>P.II-S.4.5.1</p>
<p>Water Reducer</p> <p>A water reducing admixture is the most commonly used admixture in modern concrete mixes. There are several types of water reducer of varying effectiveness – Normal Range, Medium Range and High Range. The extent of water reduction possible varies from about 10% to about 25% depending on which WR is used.</p> <p>See also <i>Admixtures</i> and <i>Superplasticiser</i>.</p>	<p>P.II-S.5.2.4</p>
<p>'Water-proofing' Concrete Additive / Admixture</p> <p>A 'water-proofing' concrete admixture is an incorrect description. Permeability reducing admixtures are used to reduce the risk of water (or fluid) flow through concrete. These admixtures are usually composite materials including very fine materials which can act as pore blockers as well as hydrophobic chemicals which alter the surface tension within pores in the concrete and prevent water moving through them. While concrete permeability can be reduced, water proofing a structure requires consideration of structural detailing as well.</p>	<p>P.II-S.5.2.5</p>
<p>Water Quality (Mixing Water)</p> <p>The quality of mixing water is an important element in concrete manufacture, particularly where potable water is not available. AS 1379 gives some guidance as to basic water quality requirements. The most practical assessment of water quality is carried out by making a concrete mix with a new water source and comparing the performance of that concrete with concrete made using a known water source. AS 1379 gives guidance as to acceptable concrete performance in terms of comparative (a) setting time and (b) compressive strength.</p> <p>See also <i>Recycled Water (as Mixing Water)</i>.</p>	<p>P.II-S.4.2</p>
<p>Wet-Batch Plant</p> <p>A 'wet-batch' concrete plant usually involves concrete components being mixed in a 'split drum' mixer at a concrete plant. Once mixing is complete the plastic concrete is unloaded from the mixer into either an 'agitator' or a tipper for delivery to the job site. 'Wet-batch' plants are generally now used where high production rates are required and where high levels of consistency of quality are required. For many concrete road pavement projects 'wet-batch' plants are chosen for both of the reasons noted. (Note: Tippers are used to transfer concrete where the mix is being produced at a low slump (20-40 mm) and where the distance to the job site is short).</p>	<p>P.IV-S.9.2.5</p>
<p>Witness Point</p> <p>Witness Points are identified points in the process where the designated authority, typically the Engineer or Consultant or 3rd Party Inspector may review, witness, inspect method or process of work.</p>	<p>P.XI.5.1</p>

<p>Workability</p> <p>Concrete workability is an important concrete characteristic which may be quite variable, depending on the nature of the element being built. The workability should be appropriate to the type of construction and the method of delivery of the concrete to the job. (e.g. concrete to be placed in thin or narrow forms will need to be very workable, while concrete to be placed in a mass construction (e.g. dam or footing) or through a paving machine will need to be less workable.) Workability may also be considered to reflect the ease with which a concrete mix can be compacted without the risk of segregation. Loss of workability due to hot, windy weather or to water being adsorbed by concrete components (e.g. fine oxides used for colouring) also needs to be considered in any project. Modification of workability by uncontrolled water addition at site is problematic.</p>	<p>P.V-S.12.2.1</p> <p>P.VIII-S.25.2.1</p>
---	--

X

--	--

Y

<p>Yield</p> <p>For a theoretical mix proportioning, it is expected that the actual wet density of a concrete mixture will be the same as designed. However, in some cases, the measured density is higher or lower than the designed value. For example, a total mass of batched materials for 1.000m³ according to a mix design is 2,350 kg/m³. When tested, the plastic density is found to be 2,320 kg/m³. This means that the concrete mix yield is equal to $2,350/2,320 = 1.013$, which is 'over-yielding' by 1.3%. In the opposite case, if the batch mass is less than the measured plastic concrete density, it is 'under-yielding'.</p>	<p>P.III.3.2</p> <p>P.IV-S.10.3.1</p>
---	---

Z

--	--

CCAA OFFICES

NATIONAL OFFICE (NSW)

Level 10
163 -175 O’Riordan Street
Mascot NSW 2020

POSTAL ADDRESS

PO Box 124
Mascot NSW 1460
Telephone: (02) 9667 8300

QUEENSLAND

Level 14, 300 Ann Street,
Brisbane QLD 4000
Telephone: (07) 3227 5200

VICTORIA

Suite 910/1 Queens Road
Melbourne VIC 3004
Telephone: (03) 9825 0200

WESTERN AUSTRALIA

45 Ventnor Avenue
West Perth WA 6005
Telephone: (08) 9389 4452

SOUTH AUSTRALIA

Level 30, Westpac House
91 King William Street
Adelaide SA 5000
Telephone: (02) 9667 8300

TASMANIA

PO Box 1441
Lindisfarne TAS 7015
Telephone: (03) 6491 2529

ONLINE DETAILS

www.ccaa.com.au
Email: info@cca.com.au

Since the information provided is intended for general guidance only and in no way replaces the services of professional consultants on particular projects, no legal liability can be accepted by Cement Concrete & Aggregates Australia for its use.

© Cement Concrete & Aggregates Australia